



**OWNER'S MANUAL  
INSTRUCTIONS- INSTALLATION-OPERATION-MAINTENANCE**

**PIZZA OVEN**

SRPO-24G, SRPO-36G

**\*\*READ THIS MANUAL IN IT'S ENTIRELY BEFORE USING THIS EQUIPMENT\*\***





## IMPORTANT SAFETY INFORMATION



**FOR YOUR SAFETY:** Do not store or use gasoline or other flammable vapors or liquids in the vicinity of this or any other appliance.



**MESURE DE SÉCURITÉ:** Ne pas entreposer ni utiliser d'essence ni autres vapeurs ou liquides inflammables à proximité de cet appareil ou de tout autre appareil.



**WARNING:** Improper installation, adjustment, alteration, service or maintenance can cause property damage, injury or death. Read the installation, operating and maintenance instructions thoroughly before installing or servicing this equipment.



**MISE EN GARDE:** Une installation, un réglage, une modification, une réparation ou un entretien inadéquat peut provoquer des dommages matériels, des blessures ou la mort. Lisez soigneusement les instructions d'installation, d'utilisation et d'entretien avant d'installer ou de réparer cet équipement



Tel.: 786 .600.4687 / Toll Free: 844.218.8477  
Fax: 786.661.4100



Tel.: 514.737.9701 / Toll Free: 888.275.4538  
Fax: 514.342.3854 / Toll Free: 877.453.8832  
service@mvpgroupcorp.com

**MVP**  
GROUP

www.mvpgroupcorp.com



### PLEASE RETAIN THIS MANUAL FOR FUTURE REFERENCE

All equipment manufactured by SIERRA CORP. is for use with the type of gas specified on the rating plate and for installation will be in accordance with National Fuel Gas Code ANSI Z223.1 (latest edition).

#### **IMPORTANT: Installing, Operating and Service Personnel:**

Qualified, certified licensed and/ or authorized personnel who are familiar with and experience in state/local installation codes should perform installation of the equipment. Qualified or authorized personnel who have read this manual and are familiar with the functions of the equipment should perform operation of the equipment.

Qualified personnel who are knowledgeable with Sierra equipment should perform service of the equipment.

The BTU input rating on all equipment is calibrated for elevations up to 2,000 feet above sea level. All orifice drill sizes are referenced for operation at or below this altitude. For operation at elevations above 2,000 feet, the BTU rating must be reduced 4% for each 1,000 feet of elevation or the orifice drill size must be changed appropriately. For high altitude drill sizes, call your local gas company or Factory Authorized Service Center

All units are equipped with fixed orifices and cannot be adjusted. If converting the gas appliance from natural to propane, or vice versa, all orifices and the regulator must be changed. The correct type of gas, for which the unit is configured, is noted on the name plate. The type of gas specified MUST be used. For proper conversion, contact a qualified service technician or your Factory Authorized Service Center.

#### **SHIPPING DAMAGE CLAIM PROCEDURE**

Merchandise must be inspected prior to the carrier leaving your premises. Damage must be noted in writing on the BOL and pictures must be taken at this time.

- For any goods shipped prepaid by MVP Group Corp., and the goods are damaged and/or lost in transit, please call the Logistics Department at MVP immediately (1-888-275-4538 x 333)

- MVP Group will not be held responsible for damages that are not notated on the BOL or not reported within 5 business days of being delivered.

- For goods shipped via 3rd party carrier, any claim for damages or loss must be made by the consignee directly with the carrier. MVP Group Corp. assumes no responsibility for damage or loss while in transit.

#### **INSTALLATION INSTRUCTIONS**

Gas pressure regulator provided with the equipment must be installed when the appliance is connected to gas supply. The area around the appliance must be kept free and clear of combustibles such as solvents, cleaning liquid, broom, rags, etc. Proper clearances must be provided at the front of the appliance for servicing and proper operation.



Tel.: 786 .600.4687 / Toll Free: 844.218.8477  
Fax: 786.661.4100



Tel.: 514.737.9701 / Toll Free: 888.275.4538  
Fax: 514.342.3854 / Toll Free: 877.453.8832  
service@mvpgroupcorp.com

**MVP**  
GROUP  
www.mvpgroupcorp.com



Provisions shall be incorporated in the design of the kitchen, to ensure adequate supply of fresh air and adequate clearance for air openings into the combustion chamber, for proper combustion, and ventilation. For proper operation of the appliance, do not obstruct the flow of combustion and ventilation air.

The installation must conform with local codes, or in the absence of local codes, to the national fuel gas code, ANSI Z223.1 (or latest addenda). The Appliance and its individual shut off valve must be disconnected from the gas supply piping system during any pressure testing of that system in excess of ½ PSI (3.45Kpa).

The appliance must be isolated from the gas supply piping system by closing its individual manual shut off valve during any pressure testing of the gas supply piping system at test pressures equal to or less than ½ PSI (3.45Kpa).

The gas supply line must be at least the same size as the gas inlet of the appliance.

### **FLEXIBLE COUPLINGS, CONNECTORS AND CASTERS**

For an appliance equipped with casters the installation shall be made with a connector that complies with the Standard for Connectors for Movable Gas Appliances, ANSI Z21.69 or Connectors for Moveable Gas Appliances, CAN/CGA-6.16, and a quick-

–disconnect device that complies with the standard for Quick Disconnect Devices for Use with Gas Fuel, ANSI Z21.41, or Quick Disconnect Devices for Use with Gas Fuel, CANI-6.9. Adequate means must be provided to limit the movement of the appliance without depending on the connector and the quick-disconnect device or its associated piping to limit the appliance movement.

Restraining devices may be attached to the back frame/panel of the unit.

All Sierra appliances are adjusted and tested before leaving the factory, effectively matching them to sea level conditions. Adjustments and calibrations to assure proper operation may be necessary on installation to meet local conditions; low gas characteristics, to correct possible problems caused by rough handling or vibration during shipment, and are to be performed only by qualified service personnel. These adjustments are the responsibility of the customer and/or dealer and are not covered by our warranty. Before lighting any pilots, make sure that burner valves and thermostats are turned “off”.

### **MAINTENANCE INSTRUCTIONS**

**CAUTION:** Never use ammonia in an oven that is warmer than room temperature and always have direct ventilation!

If the appliance is on casters and is connected to the supply piping by means of a connector for movable appliances, there is a restraining device at the rear of the unit. If disconnection of the restraint is necessary, reconnect the restraint after the appliance has been returned to its originally installed position.



Tel.: 786 .600.4687 / Toll Free: 844.218.8477  
Fax: 786.661.4100



Tel .: 514.737.9701 / Toll Free: 888.275.4538  
Fax: 514.342.3854 / Toll Free: 877.453.8832  
service@mvpgroupcorp.com

**MVP**  
GROUP  
www.mvpgroupcorp.com



## CLEANING

**DAILY:** Clean top grate(s) with warm water, mild cleaner and wire brush. Clean and brush off debris from and around the burner area. Empty and clean grease pan. Griddle plates should be cleaned with warm water and scrubbed with cleaning abrasive such as a griddle brick of fine grit type. Top surface can also be 'bleached' with vinegar, pickle juice or club soda when the plate is warm to give the plate a 'new' look.

Remove the baking racks. Wash in hot soapy water and replace after the rest of the oven is cleaned. Remove the oven bottom by lifting it out from the front then sliding forward, out of the oven. Scrape off any food particles with a nylon griddle scraper. Be very careful about scratching the porcelain finish on the oven liner panels. Wash all the above with hot soapy water, then reassemble. Baked on spills may be loosened and stubborn stains removed with ordinary household ammonia and scrubbing with a nylon pad in a cold oven only. Do not allow spray type oven cleaners to come into contact with the temperature probe in the oven. After cleaning the oven, rinse well with 1/4 cup of vinegar to one quart of clear water solution to neutralize any caustic residue of the cleaning compound. Wipe dry. To increase the life of the motor, follow these instructions: Never run oven with motor off. After you finish cooking and the oven is not to be use for more than ½ hour. Place the switch to the "COOL" position and open the door. When oven temperature is equal to room temperature turn unit off.

**PERIODIC:** Remove open burners and clean with warm water and wire brush. Make sure the ports are not clogged. Check valves and lubricate, if necessary. Consult your service agency or local Gas Company.

## STAINLESS STEEL PARTS

Do not use steel wool, abrasive clothes, cleansers or powders to clean stainless steel surfaces. All stainless steel parts should be wiped regularly with hot soapy water during the day and a stainless steel liquid cleaner at the end of the day. To remove encrusted materials, soak in hot water to loosen the material, and then use a wood or nylon scraper.

Contact the factory, factory representative or a local service company to perform repairs.



Tel.: 786 .600.4687 / Toll Free: 844.218.8477  
Fax: 786.661.4100



Tel.: 514.737.9701 / Toll Free: 888.275.4538  
Fax: 514.342.3854 / Toll Free: 877.453.8832  
service@mvpgroupcorp.com

**MVP**  
GROUP  
www.mvpgroupcorp.com



## INSTALLATION OF LEGS

### LEGS ASSEMBLY:

Mount Legs on bottom of product, the appliance may be further leveled with adjustment in the foot of the leg.

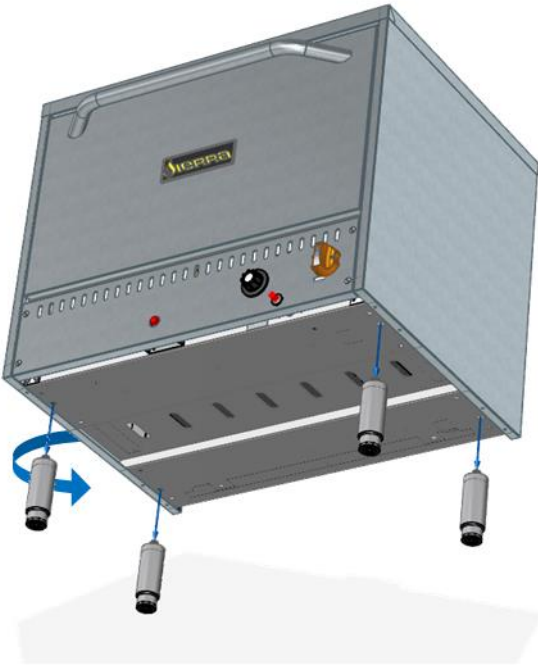

**Note:** In the "SRPO" The Legs are an extra accessory are not includes in the equipment.

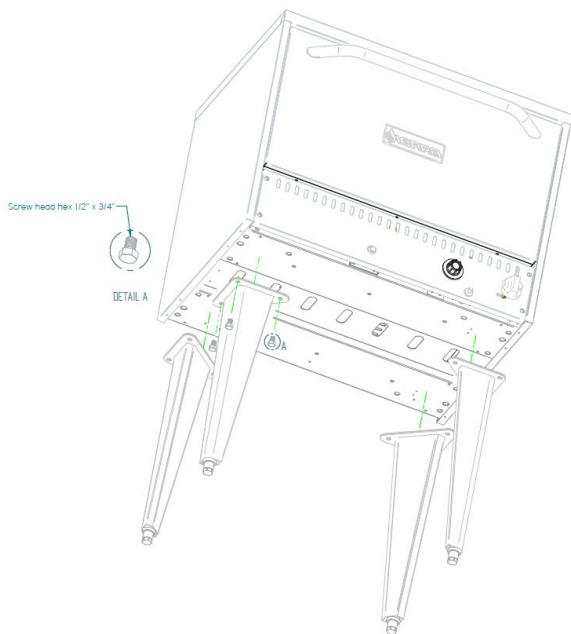

Tel.: 786 .600.4687 / Toll Free: 844.218.8477  
Fax: 786.661.4100



Tel.: 514.737.9701 / Toll Free: 888.275.4538  
Fax: 514.342.3854 / Toll Free: 877.453.8832  
service@mvpgroupcorp.com



## GAS CONNECTION

The gas supply (service) line must be the same size or greater than the inlet line of the appliance. SIERRA appliances use a ¾" NPT inlet.

Pipe joint compound must be resistive to Natural or LP gas.

For equipment using propane gas do not install supply lines with a diameter less than ½ under any circumstances.

All connections must be tested with a soapy water solution before lighting any pilots.

The appliance shall be connected to the fuel gas for which it was designed. No attempt shall be made to convert the appliance from the gas specified on the rating plate for use with a different gas without consulting the installation instructions, the serving gas supplier, or the appliance manufacturer for complete instructions.

## MANUAL SHUT OFF VALVE

This installer supplied valve must be in the gas service line ahead of the appliance regulator in the gas stream and in a position accessible in the event of an emergency.

## LOCATION

- Installation of the equipment should be performed by qualified, certified, and authorized personnel who are familiar and experienced with local installation codes.
- Before Installation please read instructions completely and carefully.
- Do not remove permanently affixed labels, warnings or plates from the product.
- Please observe all local and national codes and ordinances
- Installation must conform with local codes, or in the absence of local codes, the National Fuel Gas Code, ANSI Z223.1 (latest edition).

In Canada, installation should conform to installation codes for gas burning appliances and equipment standard CAN/CGA-B 149.1 or the Propane installation code, CAN/CGA-B 149.2, as applicable.

The appliance must be isolated from gas supply piping system, by closing its individual manual shut off valve during any pressure testing of the gas supply piping system at test pressure equal to or less than ½ psi (3.45kpa)

## CLEARANCES

The appliance area must be kept free and clear of all combustibles  
SR, SRMR Series products are for installation in Non-Combustible locations only.



Tel.: 786 .600.4687 / Toll Free: 844.218.8477  
Fax: 786.661.4100



Tel .: 514.737.9701 / Toll Free: 888.275.4538  
Fax: 514.342.3854 / Toll Free: 877.453.8832  
service@mvpgroupcorp.com



	COMBUSTIBLE	NON COMBUSTIBLE
SIDES	12 Inches	0 Inches
REAR	8 Inches	0 Inches
FLOOR	6 Inches	0 Inches

### AIR SUPPLY & VENTILATION

The area in front of, around and above the appliance must be kept clear to avoid any obstruction of the flow of combustion and ventilation air.

Adequate clearance must be maintained around the appliance for easy servicing. Provision should be made for any commercial, heavy-duty cooking appliance exhaust combustion waste products to the outside of the building. Usual practice is to place the appliance under an exhaust hood, which should be constructed in accordance to the local codes. Strong exhaust fans in this hood or in the overall air conditioning system can produce a slight vacuum in the room and / or cause air drafts, either of which can interfere with the pilot or burner performance and could be difficult to diagnose.

Air movement should be checked during installation. Air openings or baffles may have to be provided in the room, if pilot or burner outage problem persists.

### RATING PLATE

Information on this plate includes the model, serial number, BTU / hour input of the burners operating gas pressure in inches WC, and whether the appliance is orifices for natural or propane gas.

When communicating with factory about a unit or requesting for special parts or information, Rating plate data is essential for proper identification.

SIERRA COOKING APPLIANCES MUST BE CONNECTED ONLY TO THE TYPE OF GAS



Tel.: 786 .600.4687 / Toll Free: 844.218.8477  
Fax: 786.661.4100



Tel.: 514.737.9701 / Toll Free: 888.275.4538  
Fax: 514.342.3854 / Toll Free: 877.453.8832  
service@mvpgroupcorp.com



## Troubleshooting

<b>BURNER AND/OR PILOTS NOT TURN ON</b>	<b>GAS SUPPLY TO COOKING EQUIPMENT IS OFF</b>	<b>TURN ON GAS SUPPLY</b>
<b>UNIT PRODUCING CARBON DEPOSITS</b>	GAS TYPE	VERIFY CORRECT GAS
	GAS SUPPLY PRESURE	CONTACT LOCAL GAS SUPPLIER
	PRIMARY AIR NOT ADJUSTED PROPERLY	ADJUST AIR SHUTTER
	ORIFICE TOO BIG	VERIFY ORIFICE SIZE
<b>PILOT WILL NOT REMAIN LIT</b>	PILOT FLAME NOT ADJUSTED	ADJUST PILOT FLAME
	DRAFT CURRENTS NEAR EQUIPMENT	FIX DRAFT
	NOT ENOUGH VENTILATION	CONTACT HVAC CONTRACTOR
	DEBRIS OR GREASE CLOGGING PILOT BURNER	CLEAN DEBRIS AND GREASE FROM PILOT BURNER
<b>EXCESSIVE FLARE-UP</b>	OVERLOAD OF OIL AND LEFTOVERS	CLEAN AND PREPARE PAN
<b>NOT HEATING PROPERLY</b>	ORIFICES DIRTY/CLOGGED	CLEAN ORIFICE, MAKE SURE THERE IS NO RESTRICTION IN THE ORIFICE BURNER
	LOW GAS PRESSURE	INCREASE GAS PRESSURE TO 5" WC (NAT) OR 10" WC (L.P.)
	GRATES DIRTY/CLOGGED	CHECK AND CLEAN TOP GRATES
	IF THE VENTILATION IS TO STRONG IT WILL DRAFT HEAT FROM THE COOKING/BROILING SURFACE	CALL HVAC CONTRACTOR



Tel.: 786 .600.4687 / Toll Free: 844.218.8477  
Fax: 786.661.4100



Tel. : 514.737.9701 / Toll Free: 888.275.4538  
Fax: 514.342.3854 / Toll Free: 877.453.8832  
service@mvpgroupcorp.com



www.mvpgroupcorp.com



## LIMITED WARRANTY

MVP Group Corp., (Sierra Range, hereby referred to as “Sierra”), warrants all new cooking equipment bearing the name “SIERRA” and installed within the continental United States of America\* or Canada to be free from defects in material or workmanship, under normal and regular usage and operation for a period of one (1) year following the date of original installation, but in no event can exceed eighteen (18) months from the date of shipment from the factory, unless specified otherwise.

If a defect in material(s) or workmanship is detected, or found to exist within the stated period above, MVP Group Corp., at its sole discretion, shall either repair or replace any original part which has proven to fail within the machine, providing that the equipment has not been altered or tampered with in any manner, has been installed correctly as per the owner’s manual, and has been maintained and operated in complete accordance with this manual. The labor cost to repair or replace any part proven to be defective, as per above clause(s), shall be covered by MVP Group Corp., within the United States of America\* or Canada; provided that: prior authorization for this labor was pre-approved by MVP Group Corp., the service work was performed by an authorized MVP Group Corp. service agent; and that this agent installed an original and genuine Sierra part in the machine. Any repair work performed by a non-authorized service agent remains the sole responsibility of the user, and MVP Group Corp. will not be held responsible. The installation of any generic part will not be valid; and therefore voids this warranty. All authorized labor coverage shall be limited to regular hourly rates only. Any supplemental hourly rates or charges, such as weekends or emergency premiums, remain the responsibility of the user. MVP Group Corp. (Sierra) hereby states that: warranty travel time shall be limited to, and without exception, a round-trip total of two (2) hours OR mileage up to a maximum of one hundred fifty (150) kilometers round-trip. Any charges exceeding those stated herein must have prior authorization by the factory.

A special warranty covers the SRF series. These units carry the regular one (1) year parts and labor plus an additional fry tank warranty to the original end user only; if the fry tank leaks within the first two (2) years of operation due to a manufacturing defect, as confirmed by an MVP Group Corp. authorized service agent, MVP Group Corp. shall replace the fryer in its entirety. Any associated freight and/or installation charges shall not be included with the replacement. Exceptions to above warranty are: (A) Damages resulting from shipping, handling or abuse. (B) Incorrect installation and/or connections. (C) Adjustments or calibration of any thermostats or timers. (D) Faults due to lack of regular maintenance or cleaning of any internal or external part(s). (E) Replacement of any wearable items such as: baskets, grills, knobs, etc. (F) Excessive soot accumulation due to poor gas conditions. (G) Poor results due to: excessive or inadequate temperature(s) or gas pressure conditions (H) Failure to follow manual’s lighting instructions, maintenance and/or usage. MVP GROUP CORP. STATES THAT THERE ARE NO OTHER WARRANTIES, EXPRESSED OR IMPLIED, THAT ARE NOT SET FORTH HEREIN. MVP GROUP CORP. SHALL ASSUME NO OTHER RESPONSIBILITY, EITHER DIRECT OR NON-DIRECT, OR BE LIABLE FOR ANY OTHER ADDITIONAL LOSS OR DAMAGE, WHETHER DIRECT OR CONSEQUENTIAL, AS A RESULT OF ITS EQUIPMENT. \*Some exceptions apply. The manufacturer reserves the right to alter design and specifications without notice.

\*RESIDENTIAL APPLICATIONS: MVP Group Corp. assumes no responsibility nor liability for any parts, or labor coverage for component failure, or other damage resulting from installation in residential or non-commercial applications.

“Sierra Range” is a registered trademark of MVP Group Corp.



Tel.: 786 .600.4687 / Toll Free: 844.218.8477  
Fax: 786.661.4100



Tel.: 514.737.9701 / Toll Free: 888.275.4538  
Fax: 514.342.3854 / Toll Free: 877.453.8832  
service@mvpgroupcorp.com

**MVP**  
GROUP  
www.mvpgroupcorp.com



(514) 737-9701



(888) 275-4538



service@mvpgroupcorp.com



5659 Royalmount Ave  
Montreal, QC, Canada H4P 2P9



(786) 600-4687



(844) 218-8477



service@mvpgroupcorp.com



12000 Biscayne Blvd, Suite #108  
Miami, FL, United States 33181



Tel.: 786 .600.4687 / Toll Free: 844.218.8477  
Fax: 786.661.4100



Tel.: 514.737.9701 / Toll Free: 888.275.4538  
Fax: 514.342.3854 / Toll Free: 877.453.8832  
service@mvpgroupcorp.com