

HFP48-12-2S

Food Prep Table

Project Name: _____

Item #: _____ Quantity: _____



| Width* | Depth** | Height*** | Pans | Shelves | Cold Space™ | Ship Weight | Ship Cube | Cooling Capacity | Electrical |
|--------------------|-------------------|--------------------|----------------------|---------|-------------|-------------------|----------------------------------|------------------|--|
| 47 3/4" 1213 mm | 31 1/2" 801 mm | 42 1/2" 1080 mm | 12-1/6 th | 4 | 15 | 325 lbs 148 kg | 46 cu. ft. 1.3 m ³ | 1/4 HP | 115V/2.3 Amp/60 Hz - Single Phase - NEMA 5-15P, Dedicated Circuit |

* Add 1/4" (7mm) for fasteners. **Add 1/8" (4mm) for fasteners. ***Includes Hood, Casters and Lid closed. Add 5" (127mm) for Lid open. Millimeters rounded up.

Premium Features



Cassette® Refrigeration



Whisper Air-Over-Pan™



Zero Clearance Design

 Removeable
Pan Catcher™

 Finless Free&Clear™
Condenser Coil

Digitally Controlled

 Automatic Stainless
Steel Condensate
Control System

 Front Breathing
Refrigeration

Priority Air-Flow

HFP48-12-2S: Designed to enhance the food preparation experience, with attention to detail and innovation.

Refrigeration:

- Self contained Cassette® forced-air refrigeration employs R-134a refrigerant within a sealed capillary tube system.
- Cassette® refrigeration is bottom-mounted and removable from the front for ease of maintenance. Refrigeration may be exchanged or upgraded without mechanic. Designed to hold 33°F to 38°F (0.5°C to 3.3°C).
- Priority, directed air flow provides optimum cooling and energy efficiency within cabinet, over food pans and exclusively at front of unit for optimized heat exchange ventilation.
- Cold, Whisper-Air-Over-Pan™ design minimizes dehydration of food during serving.
- Finless, Free&Clear™ Condenser Coil maximizes air-flow over the compressor, reduces energy consumption and is non-clogging.
- Corrosion resistant coated evaporator coil.
- Automatic, stainless steel condensate control system.
- Equipped with Energy Efficient Digital Controller.
- Quality, self-lubricating and sealed motors with streamlined air-flow provide quieter yet robust refrigeration.

Cabinet:

- Exterior - stainless steel front, top and sides.
- Interior - NSF approved white aluminum liner with stainless steel covered corner floor.
- Ergonomic raised interior floor.
- Space Saving Zero Clearance Design - air ventilation exclusively from the front of unit.
- Exclusive Pan Catcher™ is removable through pan section opening without tools for optimum sanitation. Features easy clean-out corners for quick spill clean-up.
- Insulation - cabinet and solid doors are foamed-in-place with eco-conscious, polyurethane insulation.
- Equipped with 2 1/2" (64mm) casters, two with locks.

Doors:

- Self-Closing Swing Doors feature hold-open position, and spring-back protection.
- Foam insulated hood and lid removes for cleaning.
- Magnetic gaskets are single piece bead-mount construction easily removable for cleaning.
- Large, recessed door handle(s).

Storage:

- Four (4) white coated shelves 21 1/4"W x 25"D (540mm x 635mm), are NSF approved.
- Heavy duty aluminum shelving pilasters will not peel or chip adjustment of 1/2" (13mm) increments.
- Durable cutting surface is 11 1/2" (292mm) deep, 1/2" (13mm) thick, full length and removable. Manufactured from high-density, NSF approved white polyethylene.
- Equipped with 12 - 1/6 NSF approved polycarbonate food pans. Will accommodate 6" (153mm) deep food pans supplied by others.
- Interior accepts typical 18" x 26" (458mm x 661mm) sheet pans.
- Pan section designed to facilitate various pan sizes and configurations. Additional pan dividers available.
- NSF-7 compliant for storage and display of open food product.

Electrical:

- Factory power cord installed for connection to a sole-use (dedicated) 115V/60Hz/1-Phase, 15 Amp circuit.

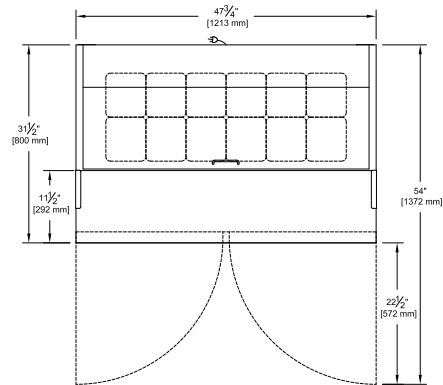
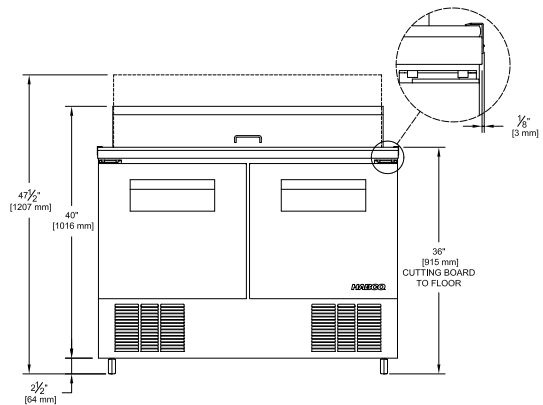

Special Inspection by CSA International

HABCO MANUFACTURING INC. 501 GORDON BAKER ROAD, TORONTO, ONTARIO, CANADA, M2H 2S6
Toll Free CAN: 1-800-387-5398 USA: 1-800-448-0244 Fax: 416-491-6982 www.habcomfg.com