

26.2" DRAFT BEER DISPENSER

SKU: 17000-099



Ensure your draught beer stays perfectly chilled and readily available for serving with this draught beer fridge.

Conveniently dispense cold, refreshing beer with just a pull of the top. This unit is simple to set up and features adjustable caster wheels and a removable drip tray for easy maintenance. Included accessories: beer tower, plastic gasket, safety guard rail, drip tray, adjustable thermostat, CO2 regulator, CO2 gas cylinder, CO2 gas cylinder support, evaporator, reversible door, metal plate, casters (2), casters with brake (2), big shelf (2), small shelf (1). Ideal for bars and restaurants, this draft beer dispenser ensures a smooth and efficient serving experience.

FEATURES:

- Easy to install
- Equipped with adjustable caster wheels
- Removable drip tray

TECHNICAL DRAWING

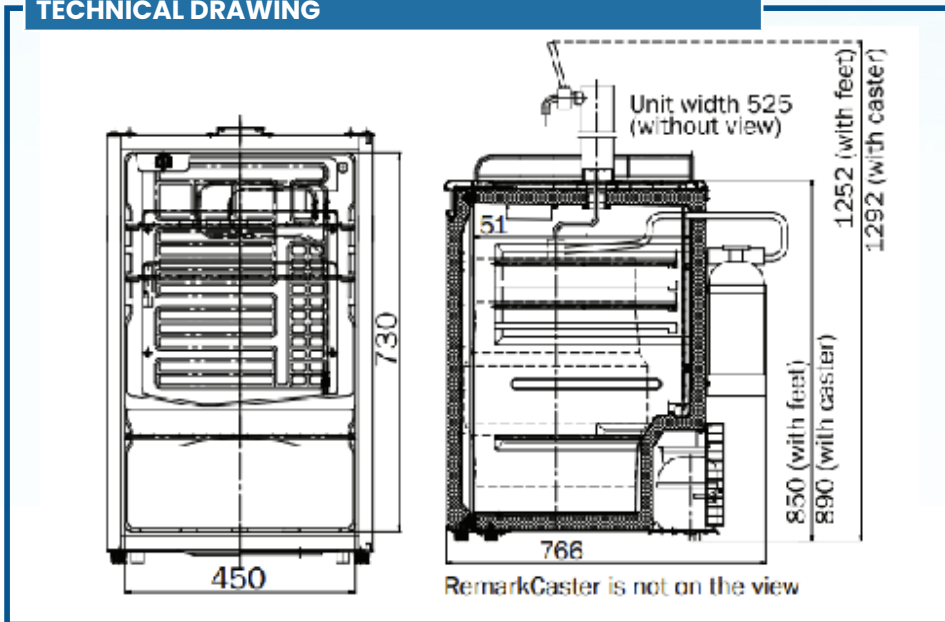

Made in China

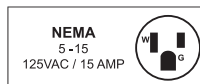



TECHNICAL SPECIFICATION

SKU	17000-099
Capacity	152 L 40.2 Gal.
Electrical	115V / 60Hz / 1Ph
Refrigerant	R600A
Temperature Range	2°C - 8°C 35.6°F - 46.4°F
Foaming Components	C - P
Keg Size Supported	58.5 L 15.5 Gal. 30 L 7.75 Gal. 20L 5 Gal.
Net Weight	79.4 lbs. 36 kg.
Net Dimensions (DWH)	20.7" x 26.2" x 33.2"
Gross Weight	88.2 lbs. 40 kg.
Gross Dimensions	22.4" x 27.2" x 34.8"

COMPATIBLE KEG TYPES

Keg is not included.

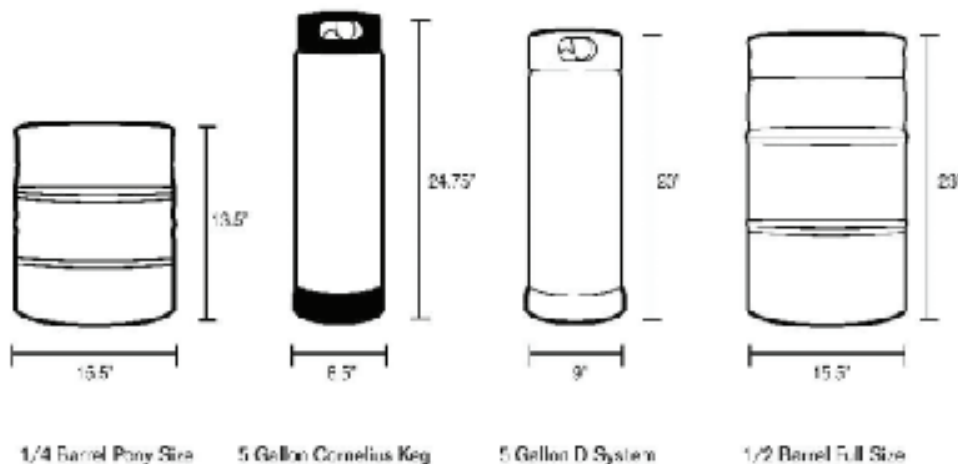

1 YEAR
WARRANTY
PARTS & LABOUR

Made in China

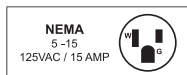

Accessories Included: beer tower, plastic gasket, safety guard rail, drip tray, adjustable thermostat, CO2 regulator, CO2 gas cylinder, CO2 gas cylinder support, evaporator, reversible door, metal plate, casters (2), casters with brake (2), big shelf (2), small shelf (1).