

23" Glass Door Black Countertop Merchandiser Display Freezer - 98L

SKU: 16000-952



Showcase your best-selling frozen treats with Zanduco's countertop display freezer. Perfect for compact areas such as convenience stores, it maximizes product visibility while fitting easily into limited spaces.

1 YEAR
WARRANTY
PARTS & LABOUR

NEMA
5 - 15R
125VAC / 15 AMP

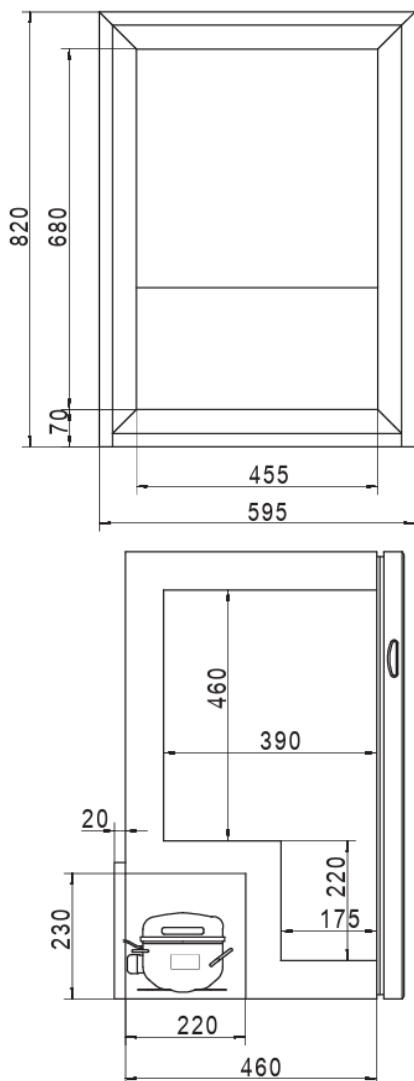

Made in China

TECHNICAL DRAWING

TECHNICAL SPECIFICATION

SKU	16000-952
Capacity	98L 3.5 cu.ft.
Temperature Range	-18°C to -20°C
Refrigerant	R290A
Max. Ambient Temperature	32°C
Defrosting	Manual
Temperature Controller	Digital Controller
Power	158W
Power Consumption	3.3 kW / 24h
Electrical	110V / 60Hz
QTY of Shelves	3
Shelf Material	Metal
Shelf Capacity	33 lb. 15 kg.
Shelf Dimensions (Big x 2)	17.4" x 14.9" 442 x 380 mm
Shelf Dimensions (Small)	17.8" x 6.7" 453 x 170 mm
Interior Dimensions (WDH)	17.9" x 15" x 26.8" 455 x 390 x 680 mm
Net Dimensions (WDH)	23" x 20" x 34" 595 x 510 x 859 mm
Net Weight	110 lb. 50 kg.
Gross Dimensions (WDH)	27" x 23" x 36" 681 x 591 x 916 mm
Gross Weight	119 lb. 54 kg.
Plug Type	NEMA 5-15R

