

Stainless Steel Reach-In Refrigerators

SKU: 12000-155

70000-678

12000-157

12000-159



An ideal solution for keeping food and ingredients fresh and ready for use.

Premium commercial reach-in refrigerators are engineered for high performance, energy efficiency, and long-term dependability. Ideal for restaurants, cafes, and foodservice operations, this unit provides generous storage capacity and reliable, consistent cooling to keep large volumes of ingredients fresh and within easy reach. Its spacious interior makes it a dependable choice for all refrigerated or frozen storage requirements.

FEATURES:

- Durable 430 stainless steel exterior
- Hygienic 304 stainless steel interior
- LCD digital temperature control for precise settings
- Self-closing doors to maintain temperature efficiency
- Automatic defrost for low-maintenance operation
- Interior lighting for improved visibility
- Adjustable shelves with PVC coating
- Heavy-duty casters equipped with locking brakes

2 YEARS
WARRANTY
PARTS & LABOUR
5 YEARS ONLY
ON COMPRESSOR

NEMA
5 - 15P
125VAC / 15 AMP

Made in China

TECHNICAL SPECIFICATION

SKU	12000-155	70000-678	12000-157	12000-159
Features	29"	40"	54"	81"
Number of Doors	1	2		3
Capacity	23 cu.ft. 650 L	26.46 cu.ft. 749.3 L	46.65 cu.ft. 1321 L	72.04 cu.ft. 2040 L
Horse Power	0.2 HP	0.5 HP	0.25+ HP	0.75 HP
Current	2.6A	4.1A	3.8A	9A
Refrigerant	R290			
Electrical	110V / 60Hz / 1Ph			
Temperature Range	0.5°C - 5°C 33°F - 41°F			
Isolation Material	Cyclopentane			
Cooling System	Ventilated			
Shelf Capacity	59.5 lb. 27 kg.	88 lb. 39.9 kg.	59.5 lb. 27 kg.	59.5 lb. 27 kg.
Number of Shelves	3	6		9
Interior Dimensions (WDH)	27.1" x 24.4" x 53.5" 688 x 620 x 1360 mm	36" x 24.4" x 51.6" 888 x 620 x 1310 mm	49.4" x 27.1" x 60.2" 1255 x 688 x 1530 mm	76.3" x 27.1" x 60.2" 1938 x 688 x 1530 mm
Net Dimensions (WDH)	29" x 32.3" x 82.5" 736 x 818 x 2095 mm	39.5" x 29.5" x 82.5" 1004 x 750 x 2095 mm	54" x 32.2" x 82.5" 1371 x 818 x 2095 mm	80.9" x 32.2" x 82.5" 2054 x 818 x 2095 mm
Net Weight	282 lb. 128 kg.	308 lb. 139.7 kg.	447.5 lb. 203 kg.	617.3 lb. 280 kg.
Gross Dimensions (WDH)	31" x 34" x 85" 787 x 864 x 2159 mm	42.2" x 31.9" x 82.5" 1070 x 810 x 2095 mm	59.7" x 35" x 83.5" 1440 x 890 x 2120 mm	83.5" x 35" x 83.5" 2120 x 890 x 2120 mm
Gross Weight	337 lb. 153 kg.	374 lb. 169.6 kg.	513.7 lb. 233 kg.	705.5 lb. 320 kg.
Plug Type	NEMA 5-15P			

TECHNICAL DRAWING: 12000-155 | 29"

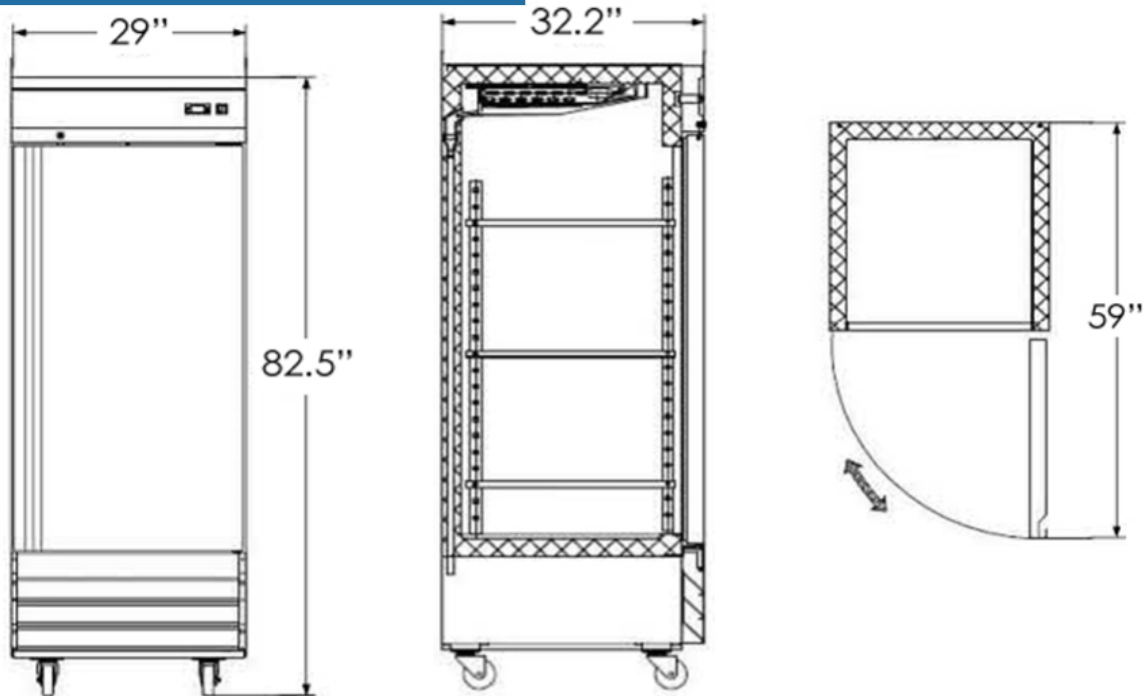

TECHNICAL DRAWING: 70000-678 | 40"

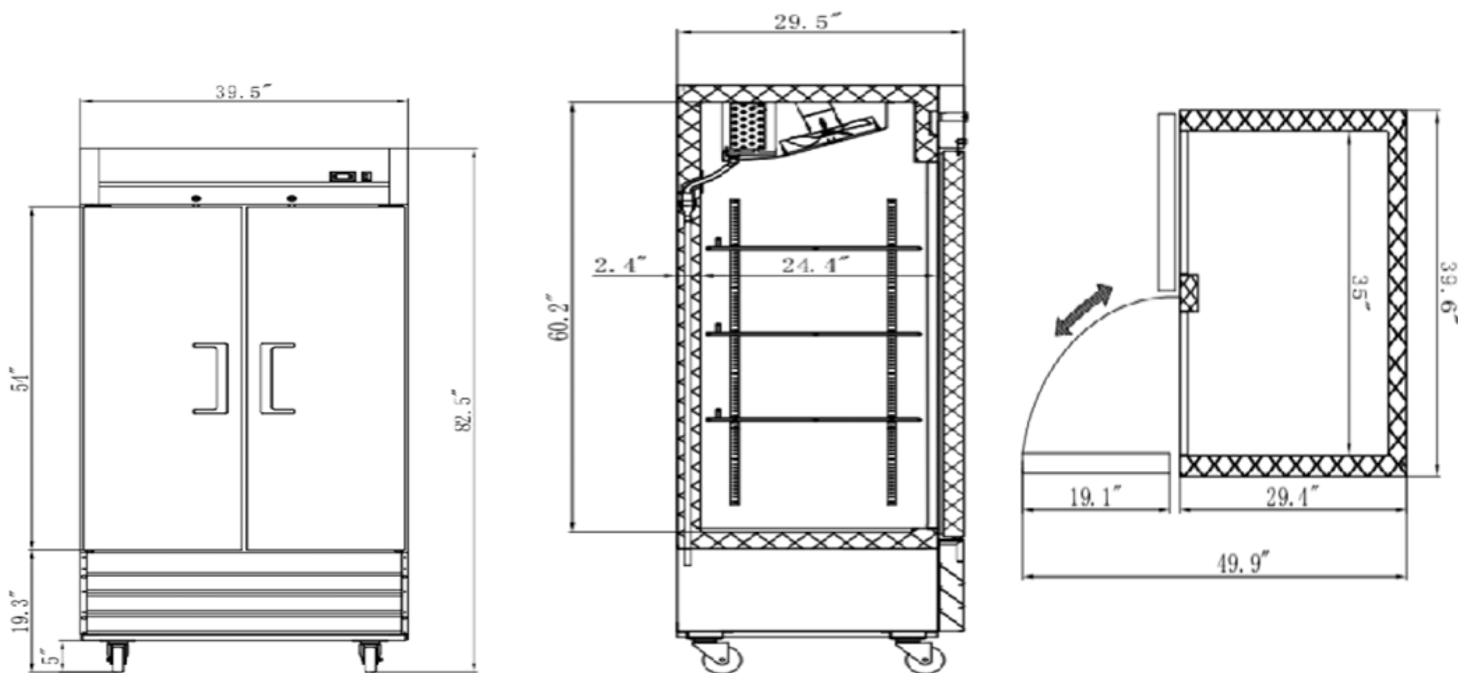

TECHNICAL DRAWING: 12000-157 | 54"

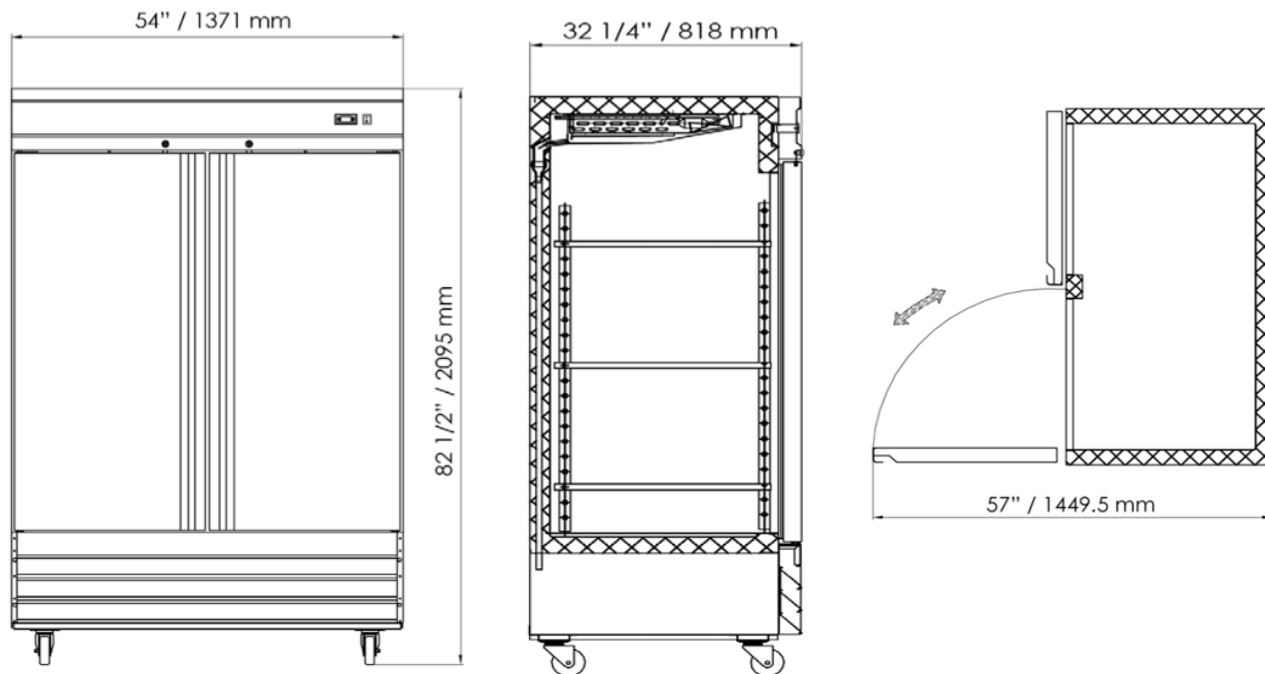

TECHNICAL DRAWING: 12000-159 | 81"

