

Weight Driven Grinder with 1 Hopper



Model G9WD-RH

(funnel sold separately)

Dimensions: 29.8" H x 8.1" W x 20" D
(75.7cm H x 20.6cm W x 50.8cm D)

Features

Weight Driven Grinder

- Weight driven technology delivers unparalleled accuracy in portion controlled coffee grinding, with three programmable batch sizes
- During grinding, the coffee type and selected batch size is communicated to the Smart Funnel
- Works with all types of brewers (both BrewWise and non-BrewWISE), from 12 cup brewers to satellite/systems brewers
- A BrewWISE brewer will read the information in the Smart Funnel, adjust the brew batch size accordingly, and brew the ideal batch of coffee
- Easy-to-use front-loading bean hoppers allow quick access for bean replenishment and cleaning
- USB port for easy programming
- The G9WD can also function as a time-based grinder should need arise
- LCD alphanumeric display shows status, programming parameters and diagnostics
- Precision grinding burrs consistently deliver the specified quality grind, and have a four year warranty
- PROP 65 Warning Decal included in packaging with equipment

Related Products

Precision Burrs

All BUNN grinders use precision burrs to cut (not crush) the coffee beans and deliver consistent grind distribution. BUNN burrs are rated at a Rockwell hardness of 66C, resulting in an exceptionally long burr life.



Coffee Container

Product No: 05792.0000

Coffee Bowl

Product No: 05891.0000

Standard Grind Burr Set

Product No: 05861.1002

Turkish Grind Burr Set

Product No: 11285.7999

Dechaffer

Product No: 05995.0000

Model

G9WD-RH

Agency Listing



Dimensions & Specifications

CANADA 

Model	Product #	Volts	Amps	Capacity lbs / kg	Cubic ft ³ /m ³	Weight lbs/kg	Cord Attached
G9WD-RH	40700.6001	120	11	6 / 2.7	6.4 / .18	68.5 / 31	Yes†

†Power cord (NEMA 5-15P) 15 Amp-120V machine only.

Electrical: 2-wires plus ground service rated 120V, 60Hz, circuit required, 3/4 HP motor.

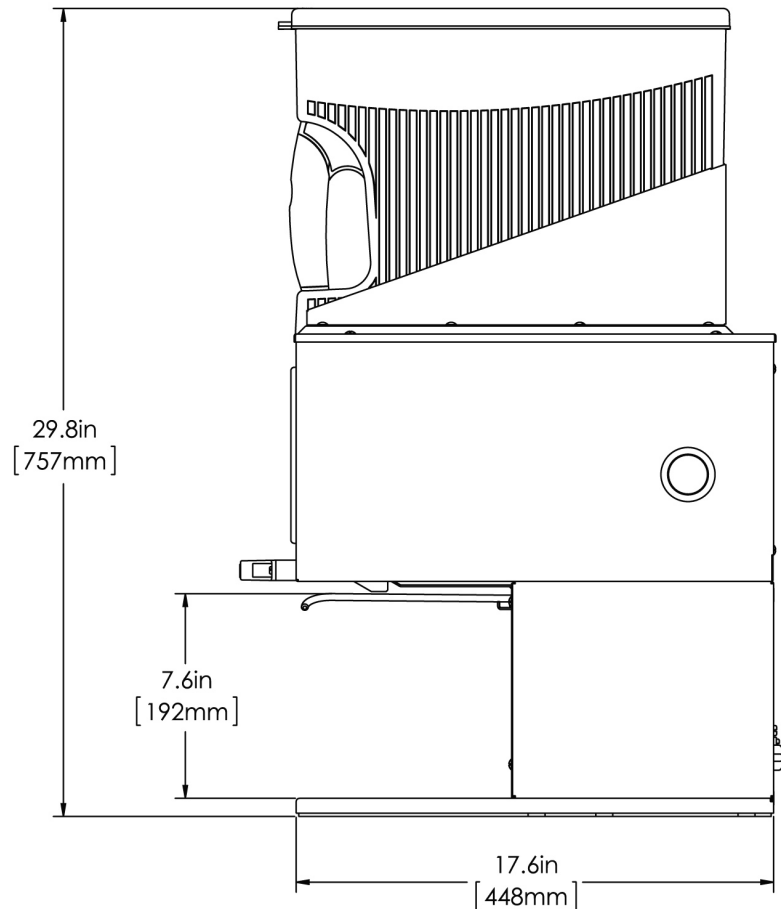
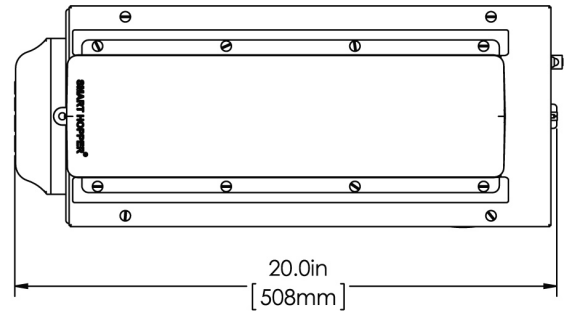
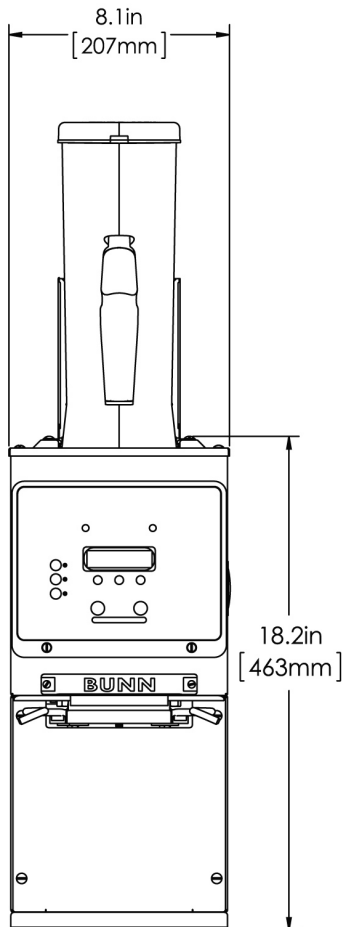

Bunn-O-Matic® Corporation of Canada • 280 Industrial Pkwy South, Aurora Ontario. L4G 3T9 • (905) 841-2866 • www.bunn.com

BUNN® practices continuous product research and improvement. We reserve the right to change specifications and product design without notice. Such revisions do not entitle the buyer to corresponding changes, improvements, additions or replacements for previously purchased equipment.

All dimensions shown in centimeters.

1/16 © Bunn-O-Matic Corporation