

SQUARE REFRIGERATED COUNTERTOP FOOD DISPLAY WARMER

SKU: 17000-408 | 17000-409 | 17000-410 | 17000-411



Excellent Display Case for Warm Food Products

Multi-levels shelves with a large capacity and crystal clear display gives unparalleled functionality, while modern design and quality materials add a premium feel to your items. This display case is sure to attract customer attention while ensuring the content remains high quality due to moisture keeping qualities of the built in water tray, and constant temperature monitoring

QPS
APPROVED
APPROUVÉ

1 YEAR

WARRANTY
PARTS AND LABOUR



NEMA
5 - 20P
125VAC / 20 AMP



TECHNICAL SPECIFICATIONS

FEATURES

- Brilliant Internal LED illumination on top
- Equipped with an adjustable temperature controller
- Temperature Display
- Adjustable chrome plated shelves
- Flat Front Glass
- Sliding Doors
- Includes Water Tray to Prevent Food Drying



27" Square Countertop Food Display Warmer

SKU	17000-408
Electrical	110V
Power	1650W
Temperature Range	30 - 90°C 86 - 194°F
Capacity	120L
Rated Current	20A
Shelf Capacity	33.1lbs 15kg
Rack Size	15.7 x 25.0-inch 14.4 x 25.0-inch 13.2 x 25.0-inch
Weight	84.9lbs 38.5kg
Dimensions (DWH)	26.7 x 22.4 x 27-inch
Gross Weight	91.5lbs 41.5kg
Gross Dimensions	29.5 x 24.7 x 28.8-inch

NEMA 5-20P | 125 VAC | 20 AMP

TECHNICAL DRAWINGS & DIMENSIONS

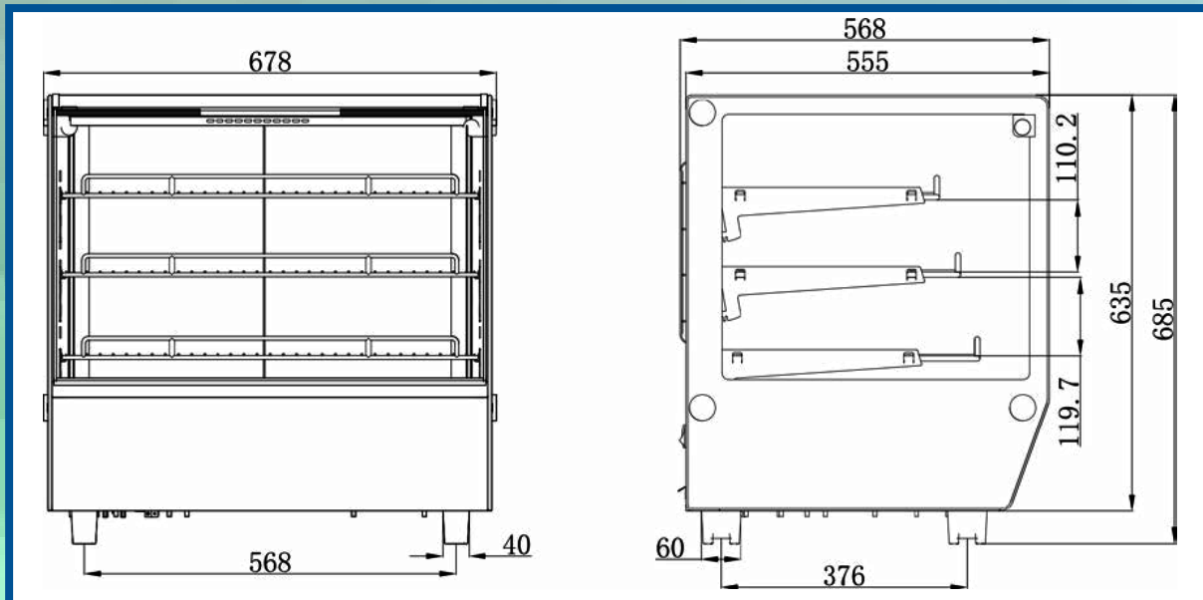

*measurements in diagrams are in mm

TECHNICAL SPECIFICATIONS

FEATURES

- Brilliant Internal LED illumination on top
- Equipped with an adjustable temperature controller
- Temperature Display
- Adjustable chrome plated shelves
- Flat Front Glass
- Sliding Doors
- Includes Water Tray to Prevent Food Drying



34" Square Countertop Food Display Warmer

SKU	17000-409
Electrical	110V
Power	1650W
Temperature Range	30 - 90°C 86 - 194°F
Capacity	160L
Rated Current	20A
Shelf Capacity	33.1lbs 15kg
Rack Size	15.7 x 32.0-inch 14.4 x 32.0-inch 13.2 x 32.0-inch
Weight	103.6lbs 47kg
Dimensions (DWH)	33.7 x 22.4 x 27-inch
Gross Weight	110.2lbs 50kg
Gross Dimensions	36.5 x 24.7 x 28.8-inch

NEMA 5-20P | 125 VAC | 20 AMP

TECHNICAL DRAWINGS & DIMENSIONS

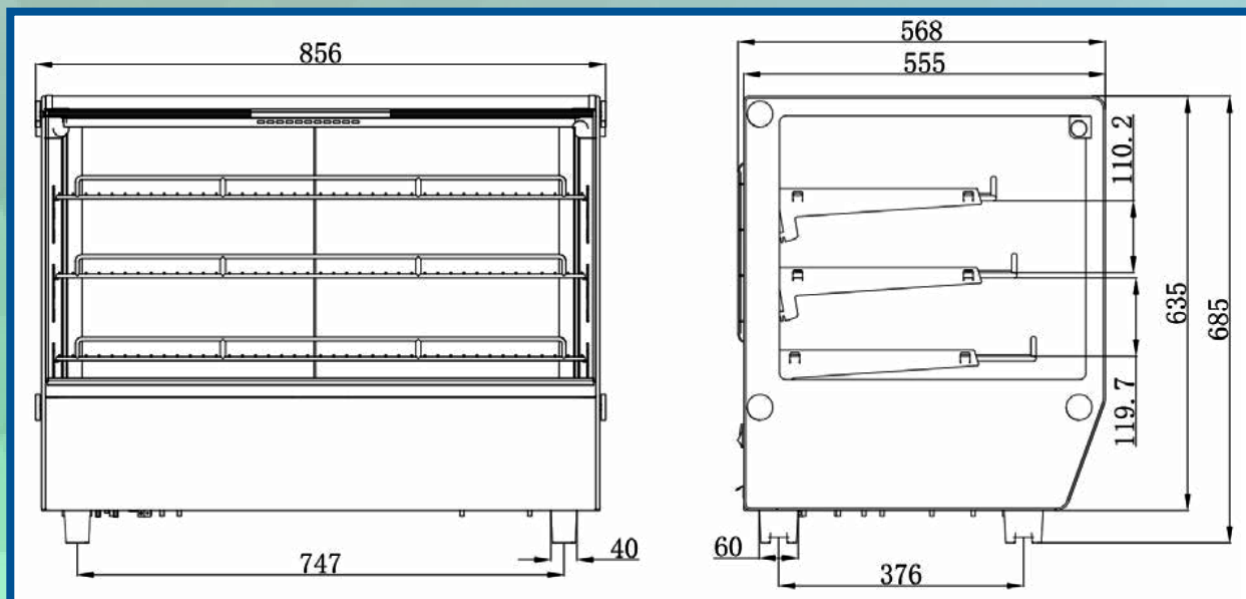

*measurements in diagrams are in mm

TECHNICAL SPECIFICATIONS

FEATURES

- Brilliant Internal LED illumination on top
- Equipped with an adjustable temperature controller
- Temperature Display
- Adjustable chrome plated shelves
- Flat Front Glass
- Sliding Doors
- Includes Water Tray to Prevent Food Drying

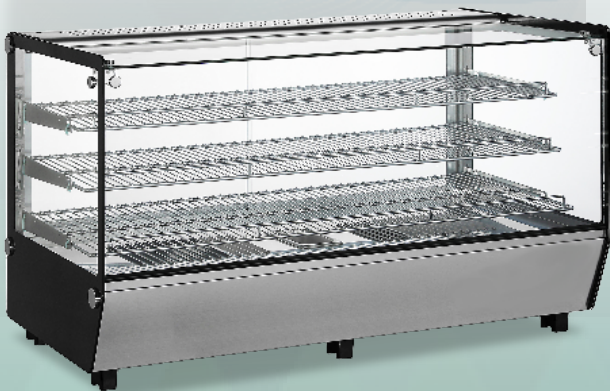

48" Square Countertop Food Display Warmer

SKU	17000-410
Electrical	110V
Power	1650W
Temperature Range	30 - 90°C 86 - 194°F
Capacity	202L
Rated Current	20A
Shelf Capacity	40.1lbs 20kg
Rack Size	15.7 x 45.9-inch 14.4 x 45.9-inch 13.2 x 45.9-inch
Weight	132.3lbs 60kg
Dimensions (DWH)	48.0 x 23.1 x 27-inch
Gross Weight	192lbs.
Gross Dimensions (DWH)	55 x 36 x 34-inch

NEMA 5-20P | 125 VAC | 20 AMP

TECHNICAL DRAWINGS & DIMENSIONS

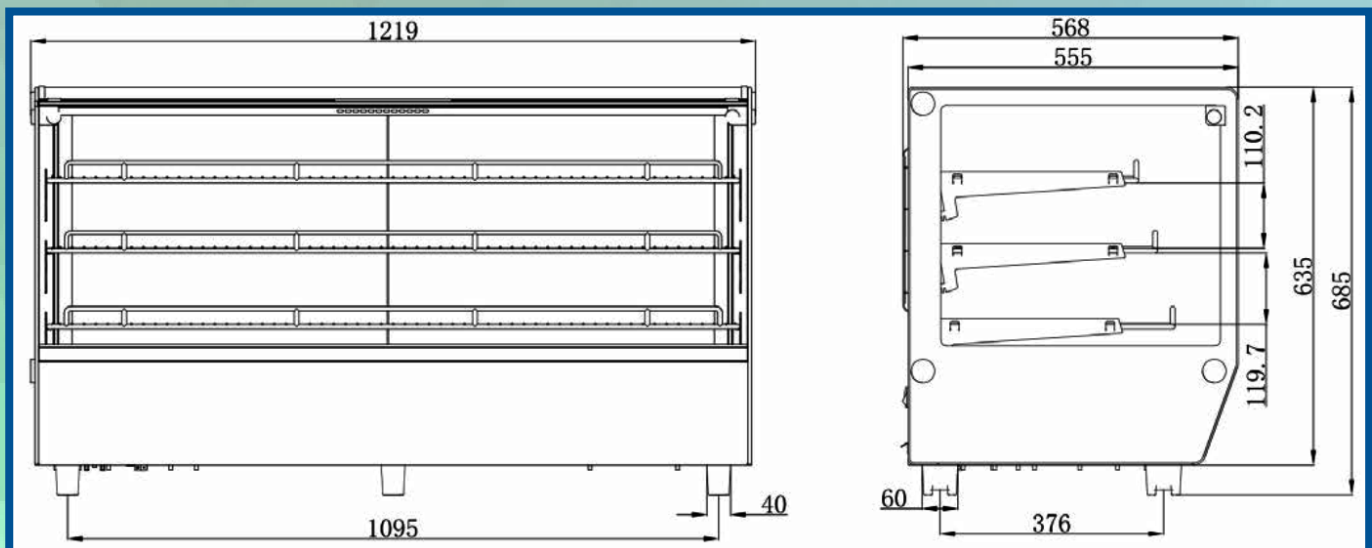

*measurements in diagrams are in mm

TECHNICAL SPECIFICATIONS

FEATURES

- Brilliant Internal LED illumination on top
- Equipped with an adjustable temperature controller
- Temperature Display
- Adjustable chrome plated shelves
- Flat Front Glass
- Sliding Doors
- Includes Water Tray to Prevent Food Drying



60" Square Countertop Food Display Warmer

SKU	17000-411
Electrical	110V
Power	1650W
Temperature Range	30 - 90°C 86 - 194°F
Capacity	252L
Rated Current	20A
Shelf Capacity	55.1lbs 25kg
Rack Size	15.7 x 45.9-inch 14.4 x 45.9-inch 13.2 x 45.9-inch
Weight	163.1lbs 74kg
Dimensions (DWH)	60 x 22.4 x 27-inch
Gross Weight	172lbs 78kg
Gross Dimensions	62.8 x 36.5 x 28.9-inch

NEMA 5-20P | 125 VAC | 20 AMP

TECHNICAL DRAWINGS & DIMENSIONS

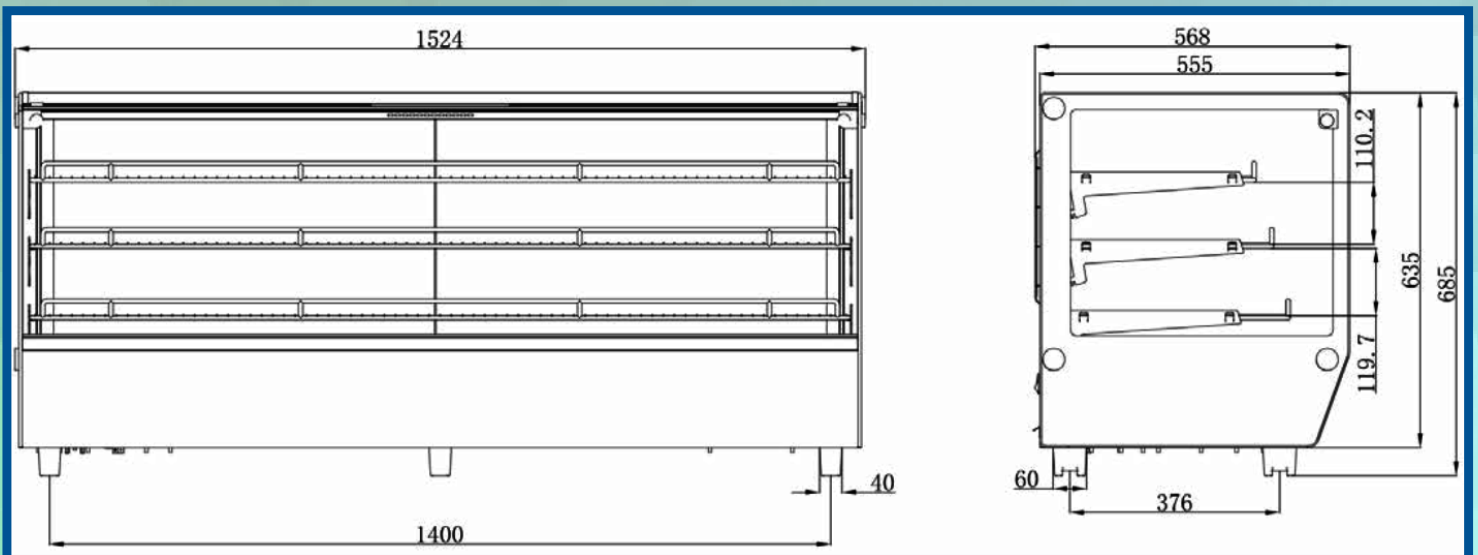

*measurements in diagrams are in mm