



Electrical Meat Mixers
Models MM-IT-0080, 0120
Items 37450, 37451
Instruction Manual



Revised - 11/05/2020



Toll Free: 1-800-465-0234
Fax: 905-607-0234
Email: service@omcan.com
www.omcan.com

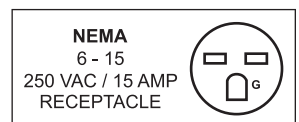

Table of Contents

Model MM-IT-0080 / Model MM-IT-0120

Section	Page
General Information -----	3 - 4
Safety and Warranty -----	4 - 6
Technical Specifications -----	6
Installation -----	7
Operation -----	8 - 9
Maintenance -----	10 - 12
Troubleshooting -----	12
Parts Breakdown -----	13 - 16
Electrical Schematics -----	17 - 18
Warranty Registration -----	19



General Information

Omcan Manufacturing and Distributing Company Inc., Food Machinery of America, Inc. dba Omcan and Omcan Inc. are not responsible for any harm or injury caused due to any person's improper or negligent use of this equipment. The product shall only be operated by someone over the age of 18, of sound mind, and not under the influence of any drugs or alcohol, who has been trained in the correct operation of this machine, and is wearing authorized, proper safety clothing. Any modification to the machine voids any warranty, and may cause harm to individuals using the machine or in the vicinity of the machine while in operation.

CHECK PACKAGE UPON ARRIVAL

Upon receipt of an Omcan shipment please inspect for external damage. If no damage is evident on the external packaging, open carton to ensure all ordered items are within the box, and there is no concealed damage to the machine. If the package has suffered rough handling, bumps or damage (visible or concealed), please note it on the bill of lading before accepting the delivery and contact Omcan within 24 hours, so we may initiate a claim with the carrier. A detailed report on the extent of the damage caused to the machine must be filled out within three days, from the delivery date shown in the shipping documents. Omcan has no recourse for damaged products that were shipped collect or third party.

Before operating any equipment, always read and familiarize yourself with all operation and safety instructions.

Omcan would like to thank you for purchasing this machine. It's of the utmost importance to save these instructions for future reference. Also save the original box and packaging for shipping the equipment if servicing or returning of the machine is required.

Omcan Fabrication et distribution Compañie Limité et Food Machinery d'Amérique, dba Omcan et Omcan Inc. ne sont pas responsables de tout dommage ou blessure causé du fait que toute personne ait utilisé cet équipement de façon irrégulière. Le produit ne doit être exploité que par quelqu'un de plus de 18 ans, saine d'esprit, et pas sous l'influence d'une drogue ou d'alcool, qui a été formé pour utiliser cette machine correctement, et est vêtu de vêtements de sécurité approprié. Toute modification de la machine annule toute garantie, et peut causer un préjudice à des personnes utilisant la machine ou des personnes à proximité de la machine pendant son fonctionnement.

VÉRIFIEZ LE COLIS DÈS RÉCEPTION

Dès réception d'une expédition d'Omcan veuillez inspecter pour dommages externes. Si aucun dommage n'est visible sur l'emballage externe, ouvrez le carton afin de s'assurer que tous les éléments commandés sont dans la boîte, et il n'y a aucun dommage dissimulé à la machine. Si le colis n'a subi aucune mauvaises manipulations, de bosses ou de dommages (visible ou cachée), notez-le sur le bond de livraison avant d'accepter la livraison et contactez Omcan dans les 24 heures qui suivent, pour que nous puissions engager une réclamation auprès du transporteur. Un rapport détaillé sur l'étendue des dommages causés à la machine doit être rempli dans un délai de trois jours, à compter de la date de livraison indiquée dans les documents d'expédition. Omcan n'a aucun droit de recours pour les produits endommagés qui ont été expédiés ou cueilli par un tiers transporteur.

General Information

Avant d'utiliser n'importe quel équipement, toujours lire et vous familiariser avec toutes les opérations et les consignes de sécurité.

Omcan voudrais vous remercier d'avoir choisi cette machine. Il est primordial de conserver ces instructions pour une référence ultérieure. Également conservez la boîte originale et l'emballage pour l'expédition de l'équipement si l'entretien ou le retour de la machine est nécessaire.

Omcan Empresa De Fabricacion Y Distribucion Inc. Y Maquinaria De Alimentos De America, Inc. dba Omcan y Omcan Inc. no son responsables de ningun daño o perjuicio causado por cualquier persona inadecuada o el uso descuidado de este equipo. El producto solo podra ser operado por una persona mayor de 18 años, en su sano juicio y no bajo alguna influencia de droga o alcohol, y que este ha sido entrenado en el correcto funcionamiento de esta máquina, y ésta usando ropa apropiada y autorizada. Cualquier modificación a la máquina anula la garantía y puede causar daños a las personas usando la máquina mientras esta en el funcionamiento.

REVISE EL PAQUETE A SU LLEGADA

Tras la recepcion de un envio Omcan favor inspeccionar daños externos. Si no hay daños evidentes en el empaque exterior, Habra el carton para asegurarse que todos los articulos solicitados estén dentro de la caja y no encuentre daños ocultos en la máquina. Si el paquete ha sufrido un manejo de poco cuidado, golpes o daños (visible o oculto) por favor anote en la factura antes de aceptar la entrega y contacte Omcan dentro de las 24 horas, de modo que podamos iniciar una reclamación con la compañía. Un informe detallado sobre los daños causados a la máquina debe ser llenado en el plazo de tres días, desde la fecha de entrega que se muestra en los documentos de envío. Omcan no tiene ningun recurso por productos dañados que se enviaron a recoger por terceros.

Antes de utilizar cualquier equipo, siempre lea y familiarizarse con todas las instrucciones de funcionamiento y seguridad.

Omcan le gustaría darle las gracias por la compra de esta máquina. Es de la mayor importancia para salvar estas instrucciones para futuras consultas. Además, guarda la caja original y el embalaje para el envío del equipo si servicio técnico o devolución de la máquina que se requiere.

Safety and Warranty

PROTECTIONS AND SAFETY FEATURES

ATTENTION

Before using the appliance make sure the safety protections are in their correct position and intact. Check they function correctly before starting work (at the beginning of a new work shift). If there are problems contact the maintenance team.

Safety and Warranty

1. Rotor protection grille.
This safety feature impedes incidental contact with the rotor.
2. Micro-switch.
3. Knob to lock tank.
4. Ball grip for locking the rotor in position.

ATTENTION!

Do Not for any reason tamper with the safety features.

DANGER AND WARNING NOTICES

ATTENTION

When the appliance is connected to the electricity supply do not touch any of the electronics. There is the risk of being electrocuted. Always respect the information given on the warning notices. Non-observance can cause injuries or even death. Make sure the warning notices are always in their correct position and are legible. If for some reason they are missing or are illegible fix them to the appliance or replace them.

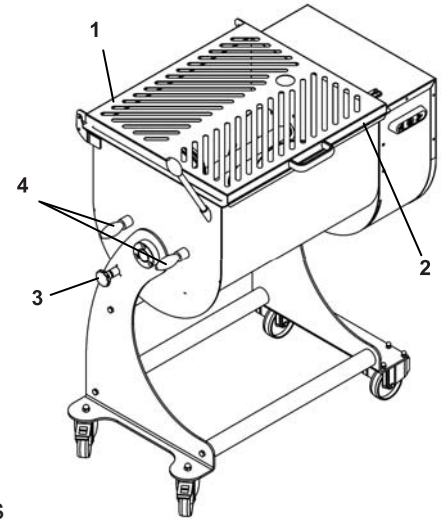

NON-PERMITTED USES

The mixer must only be used for the uses given by the manufacturer, and in particular:

- Do Not use the appliance for mixing food other than for meat.
- Do Not use the appliance if it has not been correctly installed with all the protections correctly mounted avoiding any hazardous risk of injury.
- Do Not touch any of the electrical parts without having first disconnected the appliance from the electricity supply: there is risk of electrocution.
- Do Not mix quantities that cannot be contained in the mixing drum.
- Do Not wear clothing that does not conform with the accident prevention regulations. Ask your employer regarding safety regulations and accident prevention clothing.
- Do Not turn on the appliance if faulty or out of service. Before using the appliance make sure any hazardous working conditions have been eliminated. If there is a fault or problem with the appliance immediately turn it off and inform the maintenance team.
- Do Not permit unauthorized staff to use the appliance. In case of an electrical accident the first thing to do is to pull the injured worker away from the appliance (normally in this situation the worker is unconscious). However, be very careful as this is very dangerous. The injured worker in this situation is an electricity conductor and touching him / her means being electrocuted. It is important to disconnect the electricity supply by disconnecting the fuse box and if this is not possible use an insulated object or material (wooden or PVC stick, fabric, leather, etc...) to pull the injured worker away. Immediately call the nearest casualty department so the injured worker is admitted to hospital for treatment.
- Do Not use the appliance in environments where there is gas in the atmosphere creating a high risk of combustion (explosion).
- Do Not repair the appliance without prior authorization.
- Always Respect the procedures for maintenance and technical assistance.

Safety and Warranty

1 YEAR PARTS AND LABOUR WARRANTY

Within the warranty period, contact Omcan Inc. at 1-800-465-0234 to schedule an Omcan authorized service technician to repair the equipment locally.

Unauthorized maintenance will void the warranty. Warranty covers electrical and part failures, not improper use.

Please see <https://omcan.com/disclaimer> for complete info.

WARNING:

The packaging components are classified as normal solid urban waste and can therefore be disposed of without difficulty.

In any case, for suitable recycling, we suggest disposing of the products separately (differentiated waste) according to the current norms.

DO NOT DISCARD ANY PACKAGING MATERIALS IN THE ENVIRONMENT!

Technical Specifications

Model	MM-IT-0080	MM-IT-0120
Power	550 W / 0.75 HP (x2)	735 W / 1 HP (x2)
Electrical	220V / 60Hz / 1	220V / 60Hz / 3
Tank Dimensions	24" x 20" / 610 x 508mm	26" x 21.7" / 660 x 551mm
Capacity	110 L / 80 kgs.	163 L / 120 kgs.
Dimensions	25" x 39" x 41" / 635 x 991 x 1041mm	27.6" x 43" x 40.5" / 701 x 1092 x 1029mm
Weight	198 lbs. / 90 kgs.	304.2 lbs. / 138 kgs.
Packaging Dimensions	47" x 26" x 51" / 1194 x 660 x 1295mm	29.5" x 57" x 51.2" / 749 x 1448 x 1300mm
Packaging Weight	242.5 lbs. / 110 kgs.	368.2 lbs. / 167 kgs.
Item Number	37450	37451

Installation

ATTENTION!

The work surface or area where the appliance is to be installed must be horizontal and solid guaranteeing stability and safety. When installing the appliance bear in mind that amp space must be left around the appliance. This space allows you to work freely with the appliance and allows easy access when servicing or repairing it. Provide suitable lighting around the appliance for the worker using the meat mixer.

INSTALLING

To move the package use a fork-lift truck or similar means. The appliance is in a carton box and packed on a pallet.

- Remove the two plastic straps that hold the carton box to the pallet.
- Remove the carton box.
- Remove the cellophane wrapping and any other packaging materials.

DISPOSING OF PACKAGING

Packaging materials such as carton, nylon and wood are all products considered normal urban waste. These materials can be disposed of as per normal procedures. If the appliance is destined to countries where there are specific waste laws, dispose of packaging conforming with the local laws in force.

HANDLING APPLIANCE

As the following models 50 - 120 M/B 50 - 120 - 80 - 180 BA have wheels they can be manually moved by pulling

CONNECTING TO ELECTRICITY SUPPLY

ATTENTION!

Check the electricity supply corresponds to the value given on the appliance ID plate. Electrical works can only be carried out by specialised and authorized staff with prior authorisation by the person in charge of the appliance. Connect the appliance to a circuit provided with an efficient earth socket. If necessary use suitable extension leads guaranteeing safety. The section (thickness) of the extension lead must be greater than the appliance power supply cable. This avoids any hazardous overheating. Avoid pulling or twisting the power cable as this can damage the internal wires.

Operation

LIST OF CONTROLS AND INDICATORS

CONTROL PANEL

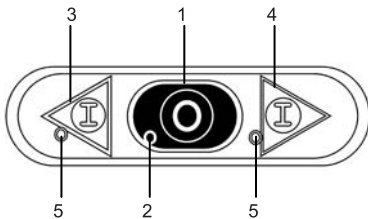

1. Stop button.
 - Black.
 - Press to stop rotor motor.
2. Light indicator for tension.
 - Green.
 - Indicates power supply. On the stop button marked with “1” it is green and remains lit when the appliance has power.
3. Start button.
 - Grey.
 - Press for starting the rotor.
4. Push button for inverting rotation.
 - Grey.
 - Press to invert rotation in the opposite direction to push button “3”.
5. Light indicators rotor in movement.
 - Red / yellow-colored.
 - Indicates that the rotor is in movement. This indicator is located near start push button “3”, and near push button for inverting rotation “4”. It is red and lights up when the rotor command is given.

STAINLESS STEEL CONTROLS

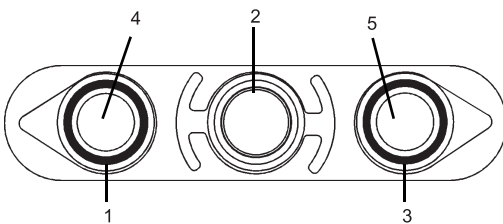

1. Drive push-button (continuous).
 - In stainless steel.
 - Press to start the blade.
2. Stop push-button.
 - Press to stop the propeller transmission motor.
3. Reverse drive push-button.
 - In stainless steel.
 - Press to start the blade in opposite direction to pus-button “1”.
4. Network presence indicator light.

- Signals that the machine is connected to the electrical network.
5. Drive indicator light.
- Signals that the tool of the machine is in movement.
 - Located close to the start push-button “3” and close to the reverse drive push-button “3”.
 - Visible only when the control is operating.

TURNING THE APPLIANCE ON AND OFF

CHECKING CONNECTION TO ELECTRICITY SUPPLY

Switch the on/off switch on the appliance to position “1”. The green light “2” should come on, indicating power on. Press push button “3” for starting, the red indicator light “5” should come on, and then immediately press push button “1” for stopping. This is to check that the appliance works correctly. Press push button “4” for starting, the red indicator light “6” should come on, and then immediately press push button “1” for stopping. This is to check that the rotor rotates in an opposite direction to push button “3”.

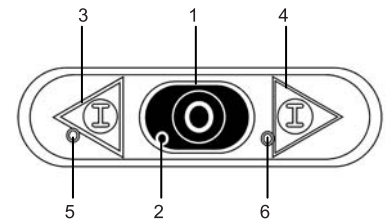

CHECKING PROTECTIONS AND SAFETY FEATURES AND THEIR EFFICIENCY

1. Rotor Protection grille.
Visually check that the protection grille is intact.
2. Micro-switch.
With the appliance running, check that it automatically stops when the protection grille is raised. If this is not the case contact your local authorised dealer or the manufacturer.

ATTENTION!

If the previously mentioned safety protections and casing are not intact, are damaged, missing or work incorrectly, turn the appliance off and contact the after-sales assistance to repair the appliance.

TURNING ON THE APPLIANCE

Switch the power on/off switch from position “0” to “1”. Indicator “2” should light up indicating power on. Press push button “3” for starting the rotor.

TURNING OFF THE APPLIANCE

To stop the appliance press push button “1” (stops the electric motor), the red indicator light “5” will go out. Indicator light “2” will remain on indicating power on. Switch the power on/off switch to position “0” turning off the power supply.

INVERSION

To invert rotor rotation press push button “4”.

Note: When a work shift is over always switch the on/off power switch to position “0”.

Maintenance

EMPTYING AND CLEANING

EMPTYING THE MIXING BOWL

Turn off the mixer, the on/off switch is in position "0" unplug from main power supply. The mixing bowl is designed to rotate to facilitate emptying.

- With the bowl in a horizontal position grip the handle on the bowl tilting bar.
- Pull the tank locking knob.
- Once having released the mixing bowl rotate by pulling the tilting bar.
- Open the protection grille and empty the bowl.

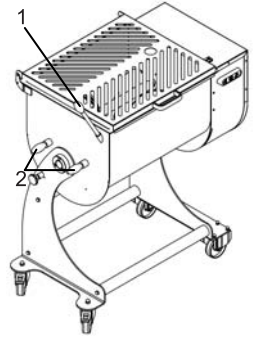

CLEANING THE MIXING BOWL

With the machine off and switch in position "0" and with the plug removed from the socket proceed with cleaning the bowl. Thanks to the possibility of rotating the bowl cleaning operations are facilitated.

- With the bowl in a horizontal position grip the handle on the bowl tilting bar (1).
- Unhook and remove the pins which lock the mixing blades (2) in position.
- Unscrew the bowl locking knob (3) anti-clockwise.
- Once having released the mixing bowl rotate by pulling the tilting bar (1).
- Open the grille (4) and proceed with removing the mixing blades.
- Make sure the mixing blades are positioned to allow for enough space to remove them.
- Grip the mixing blades one at a time (5) and pull outwards to remove.
- The surface is now smooth and easy to clean, clean the mixer thoroughly and if necessary disinfect.
- With a sponge soaked with water and a neutral (pH 7) and non-toxic degreaser (food grade) clean and remove any food product left on the mixer and on the mixing blades. Do not use petrol, solvents or other flammable liquids as detergents; only used authorised non-toxic and non-flammable solvents. Take all the necessary precautions adopting also appropriate protections required for the cleaning product being used when cleaning and disinfecting the mixer. Always follow the instructions provided for the cleaning product being used.
- To mount the mixing blades after cleaning, simply reverse the above steps.

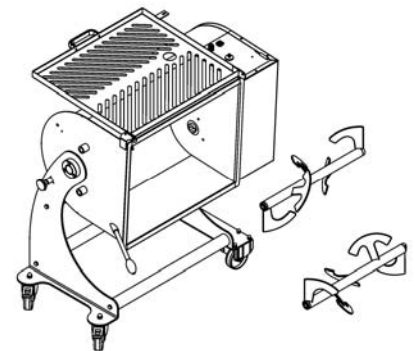
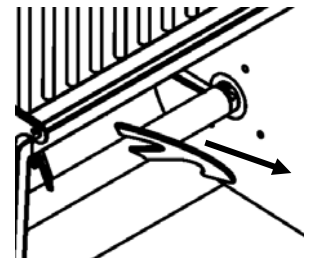
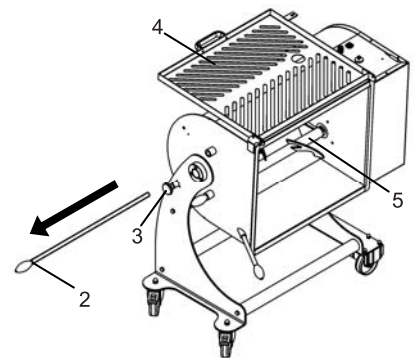

CLEANING THE APPLIANCE

At the end of the work shift the appliance must be carefully cleaned and disinfected.

- Stop the appliance and switch the on/off switch to "0" and remove the power plug.
- With a sponge soaked with water and suitable neutral degreasers (non-toxic) remove and clean any traces of food.

Do not use petrol, solvents or other inflammable liquids such as detergents. Use authorised non-toxic and non-inflammable solvents.

Take suitable precautions when cleaning considering the products being used. Always follow the instructions

for use given.

ATTENTION!

The mixer must always be off and the power plug removed from the power socket when servicing and cleaning. The maintenance area must always be clean, dry and well illuminated. Do not allow unauthorized staff to service the appliance. Do not put parts of your body, hands or arms into the mixer or openings not protected where there is the risk of being injured. Always use protective clothing (suitable gloves, glasses etc.) Do not use petrol, solvents or other inflammable liquids such as detergents. Use authorised non-toxic and non-inflammable solvents. Do not compressed air to clean the appliance. If it is considered necessary to use compressed air, use eye protection (glasses) with side protections and limit pressure to a max of 2 atm. (1,9 bar). Do not use a naked flame as lighting when servicing and repairing the appliance.

MAINTENANCE CHECKS

CHECKS AND TESTS TO BE CARRIED OUT WHEN INSTALLING

To make sure the appliance has not been damaged when delivered or when being installed, carry out the following tests;

BEFORE SETTING TO WORK:

- Check that the power supply tension corresponds to the value given on the ID plate.
- Check that there are all the warning and ID plates and that they are not damaged.
- Check that the power supply cable is not damaged and is intact.
- Check that the safety features such as the magnetic sensors are intact and not damaged.

FUNCTIONAL CHECKS WITH THE APPLIANCE RUNNING:

- Check the efficiency of the protections and safety features. There is the possibility that during transport these have been damaged or are out of adjustment.
- Carry out several functional tests using pieces of food that are the same size that will be used in normal working conditions.

PERIODICAL CONTROLS

To maintain reliability and performance in time, as well as proceeding as indicated, it is necessary to carry out regular tests and checks as follows:

BEFORE EACH WORK SHIFT:

- Every day check safety features and protections work correctly.
- Check the power cable is intact.

THE END OF THE WORK SHIFT:

- Carefully clean the appliance removing any traces of food.
- Remove, clean and mount rotor and blades.

Maintenance

LUBRICATION

Periodically grease gears (2).

- Unplug the machine from its power source.
- Take off the protective casing (1).
- Grease the gears using a brush.
- Reassemble the casing and fasten the screws.

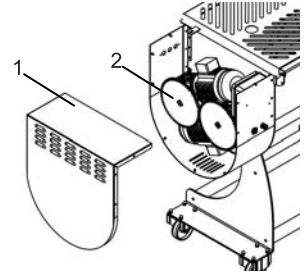

The oil in the transmission reduction gears is long-life and does not need to be ever replaced.

Troubleshooting

Problem	Cause	Remedy
The appliance does not start.	The on/off switch is in position "0".	Switch the switch to position "1".
	The grill is raised.	Lower the grill.
	The microswitch mounted on the mixing drum does not work.	Contact Omcan.
	Either the electric motor or the command circuit board is faulty.	Contact Omcan.
	The controls do not work or the blades do not change direction.	Contact Omcan.

Parts Breakdown

Model MM-IT-0080 37450

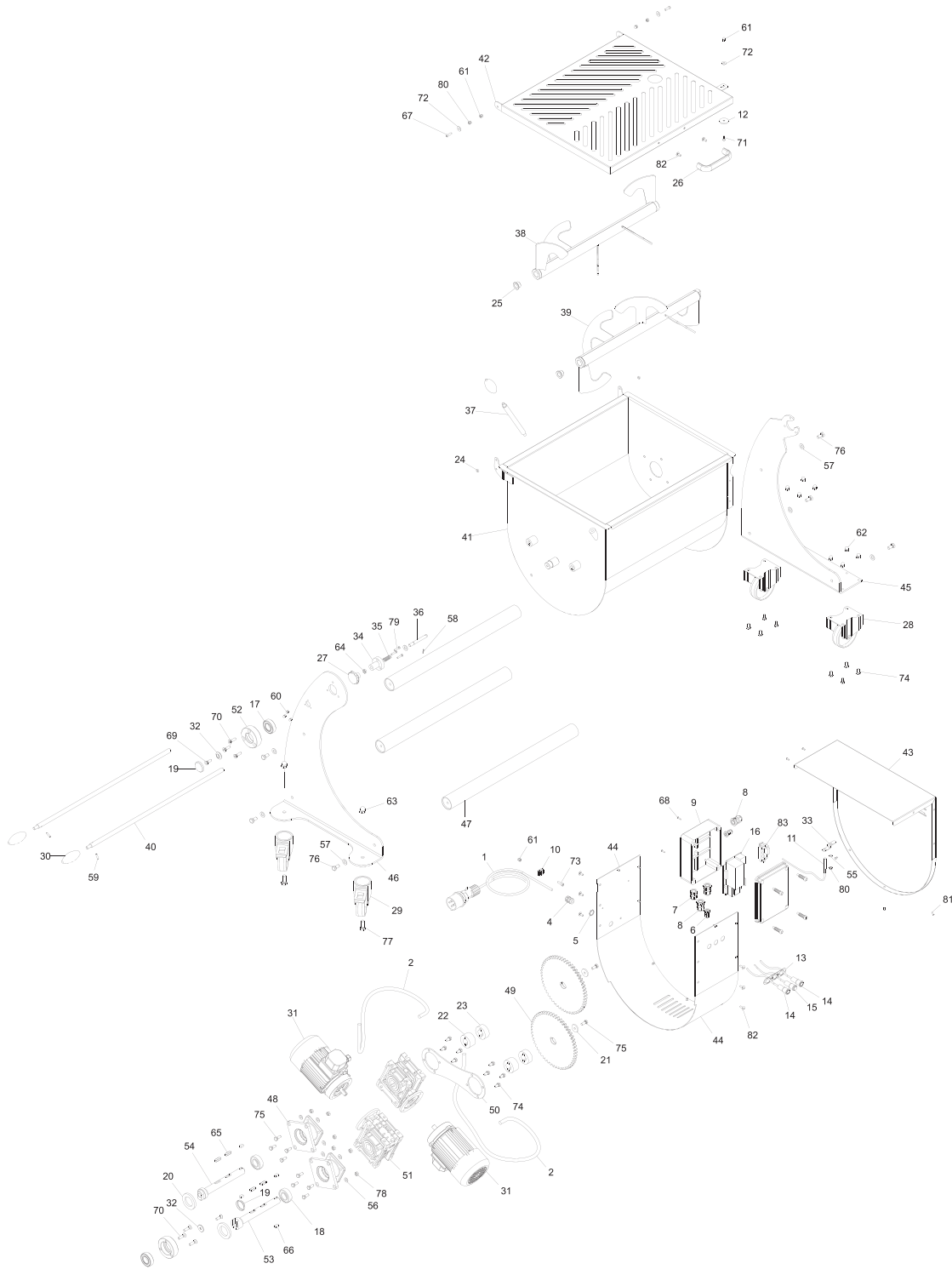

Parts Breakdown

Model MM-IT-0080 37450

Item No.	Description	Position	Item No.	Description	Position	Item No.	Description	Position
62601	Cable + Plug CEE 2P + T for 37450	1	61579	Mobile Wheel with Brake D 100 C/ PERNO for 37450	29	62644	AT Washer Din 125 D 8 for 37450	56
62602	Power Lead, Motor TF/1,5 for 37450	2	78634	Knob for 37450	30	62645	Flat Washer DIN 125 D 10 for 37450	57
61604	Strain Relief + Nut for 37450	4	62624	Mot. Pam 71 B 14 4 Poli Mono ME Evo for 37450	31	62646	Elastic Spine DIN 1481 3x18 for 37450	58
61603	Nut OTT.NICH.PG 11 for 37450	5	61590	Washer SO 1650 Inox for 37450	32	62647	Ina Elastica Din 1481 5x20 for 37450	59
62605	Essacavo Plastica PG7 for 37450	6	61587	Door Support for Microswitch for 37450	33	62648	Blind Nut DIN 1587 M5 for 37450	60
62606	Essacavo Plastica PG 11 for 37450	7	61569	Boat Stops Crade for 37450	34	61583	Nut DIN 1587 M 6 for 37450	61
62607	Essacavo + Dado Plastica PG for 37450	8	61571	Spring for 37450	35	62650	P Nut Din 1587 M8 for 37450	62
61549	Box GW 44207 for 37450	9	61570	Pin for 37450	36	62651	Dado Cieco Din 1587 M12 for 37450	63
62608	Morsetto A Pettine X Equipotenz. BZ for 37450	10	61564	Lever Rod for Container Overturning for 37450	37	62652	T ES. Din 439 M10 Basso for 37450	64
37258	Microswitch_SO Inox for 37450	11	AC923	Female Blade for 37450	38	62653	Nguette Din 6885/A 8x7x28 for 37450	65
37260	Magnet M634 for 37450	12	62628	Male Blade for 37450	39	62654	Linguetta Din 6885/AB 8x7x16 for 37450	66
62609	Frame for 3 Buttons Stainless Steel Panel for 37450	13	61563	Blade Rod for 37450	40	62655	Vite Tbei Iso 7380 M6x25 for 37450	67
60396	Stainless Steel On Button with Lamp for 37450	14	62629	Culla Inox ME 80 Evo Bialb for 37450	41	62656	TE Autof.TC + Din 7981 D 3, 5x16 for 37450	68
60397	Stainless Steel Off Button for 37450	15	62630	Coperchio Vasca ME 80 Evo Bialb for 37450	42	62657	Screw TSPEI DIN 7991 M8x20 for 37450	69
62612	Circuit Board R3+Autom EQ for 37450	16	62631	Carter Motore ME 80 Evo Bialb for 37450	43	62658	TE Tspei Din 7991 M8x30 for 37450	70
61586	Bearing 6205 ZZ for 37450	17	62632	Fascia Carter Mot. ME 80 Evo Bialb for 37450	44	62659	TE Tsp Torx Din 7991 M6x16 TX30 for 37450	71
61597	Bearing Reg. SP 7205 ME 80 EVO for 37450	18	62633	Base DX Rid. ME 80 Evo Bialb for 37450	45	62660	Sher Large Din 9021 D 6x18 for 37450	72
61589	Cap 40/7/C Pulley 1C SO1650 for 37450	19	62634	Base SX ME 80 Evo Bialb for 37450	46	62661	Hex.Socket Head Cap Screw M6x20 for 37450	73
61596	Gasket 40-62-7 for Mincer for 37450	20	62635	Tubo Unione Basi ME 80 Evo Bialb for 37450	47	62662	Screw TE DIN 933 M8x16 T.F. for 37450	74
61610	Zinc Washer M8x30 H4 for 37450	21	61592	Flange Support ME 80 EVO BIALB for 37450	48	62663	X.Screw Din 933 M8x20 for 37450	75
61607	Bushing ME 80 EVO for 37450	22	61605	Ring Gear ME 80 EVO for 37450	49	62664	TE Din 933 M10x20 T.F for 37450	76
62619	Dist. Rid-Corona Dent. SP=20 ME Evo for 37450	23	62638	Staffa Blocco Riduttori ME 80 Evo for 37450	50	62665	TE Din 933 M12x30 T.F for 37450	77
61609	Door Screw 10x6x4 ME BA EVO for 37450	24	62639	Ridut. CM50 71 B14 I50 80 Evo Bialb for 37450	51	62666	Hex.Nut DIN 934 M8 for 37450	78
62621	Cola Flang. JFM-1622-12 TCM-ME for 37450	25	61585	Shaft Support SX EVO BIALB for 37450	52	62667	Athead CSK Screw Din 963 M5x25 for 37450	79
18961	Handle for 37450	26	61595	Perno Trasc.Femm L=220 ME 120 Evo for 37450	53	62668	Cknot ES Din 982 M6 Alto for 37450	80
79656	Knob for Fixing Container for 37450	27	61598	Perno Trasc.Masc L=220 ME 120 Evo for 37450	54	62669	TE Poeliers M4x10 for 37450	81
61556	Stainless Steel Non-Swivel.Caster D.100 for 37450	28	62643	Flat Washer Din 125 D 6 for 37450	55	62670	B Overload Protection EQ for 37450	82

Parts Breakdown

Model MM-IT-0120 37451

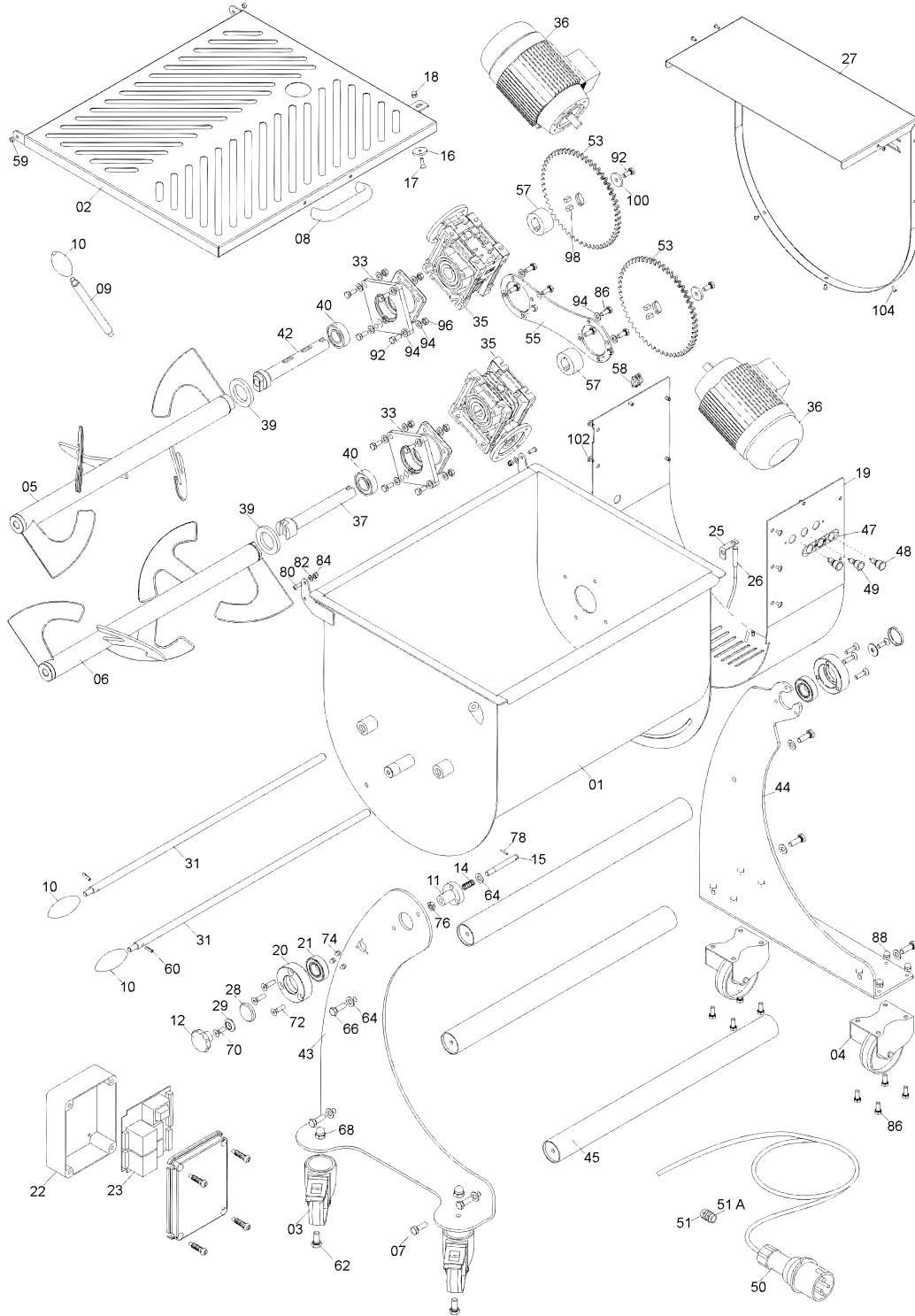

Parts Breakdown

Model MM-IT-0120 37451

Item No.	Description	Position	Item No.	Description	Position	Item No.	Description	Position
61577	Cradle INOX ME 120 EVO BIALB for 37451	1	61584	Carter Band MOT. ME 120 EVO BIALB for 37451	19	61597	Bearing Reg. SP 7205 ME 80 EVO for 37451	40
61578	Tank Cover ME 120 EVO BIALB for 37451	2	61585	Shaft Support SX EVO BIALB for 37451	20	61598	PERNO TRASC.MASC L=220 ME 120 EVO for 37451	42
61579	Mobile Wheel with Brake D 100 C/Perno for 37451	3	61586	Bearing 6205 ZZ for 37451	21	61599	Base SX ME 120 EVO BIALB for 37451	43
61556	Stainless Steel Non-Swivel Caster D.100 for 37451	4	61549	Box GW 44207 for 37451	22	61600	Base DX RID. ME 120 EVO BIALB for 37451	44
61580	Paddle Female IX ME 120 KG Bialbero for 37451	5	41224	Circuit Board R3+AUTOM EQ_IP BA XP for 37451	23	61601	Tube Union Bases ME 120 EVO BIALB for 37451	45
61581	Paddle Male IX ME 120 KG Bialbero for 37451	6	61587	Door Support for Microswitch for 37451	25	61561	Switch for PCB Taglioretti for 37451	48
18961	Handle for 37451	8	37258	Microswitch SO INOX/IP BA/TC32F/GF for 37451	26	37179	Gasket for Round Control Panel C6-C9 P-802 for 37451	49
61564	Lever Rod for Container Overturning for 37451	9	61588	Motor Cover ME 120 EVO BIALB for 37451	27	61602	Cable and Plug CEE 3P + T. for 37451	50
78634	Knob for 37451	10	61589	Cap 40/7/C Pulley 1C SO1650 for 37451	28	61604	Strain Relief + Nut for 37451	51
61569	Boat Stops Crade for 37451	11	61590	Washer for Bone Saw SO 1650 INOX for 37451	29	61603	Nut OTT.NICH.PG 11 for 37451	51 A
79656	Knob for Fixing Container IP 50-100 for 37451	12	61591	Paddle Rod IX ME 120 KG Bialbero for 37451	31	61605	Ring Gear ME 80 EVO for 37451	53
61571	Spring for 37451	14	61592	Flange Support ME 80 EVO BIALB for 37451	33	61606	Bracket Lock Gear ME 120 EVO for 37451	55
61570	Pin for 37451	15	61593	RIDUT. CM63 80 B14 I50 120 EVO BA for 37451	35	61607	Bushing ME 80 EVO for 37451	57
37260	Magnet M634 for 37451	16	61594	MOT. PAM 80 B 14 4 POLI TRIF ME EVO for 37451	36	61608	Terminal Comb BZ for 37451	58
61582	Screw TSP TORX DIN 7991 M 6x12 TX30 for 37451	17	61595	PERNO TRASC.FEMM L=220 ME 120 EVO for 37451	37	61609	Door Screw 10x6x4 ME BA EVO for 37451	59
61583	Nut DIN 1587 M 6 for 37451	18	61596	Gasket 40-62-7 for Mincer for 37451	39	61610	Zinc Washer M8x30 H4 for 37451	100

Electrical Schematics

Model MM-IT-0080 37450

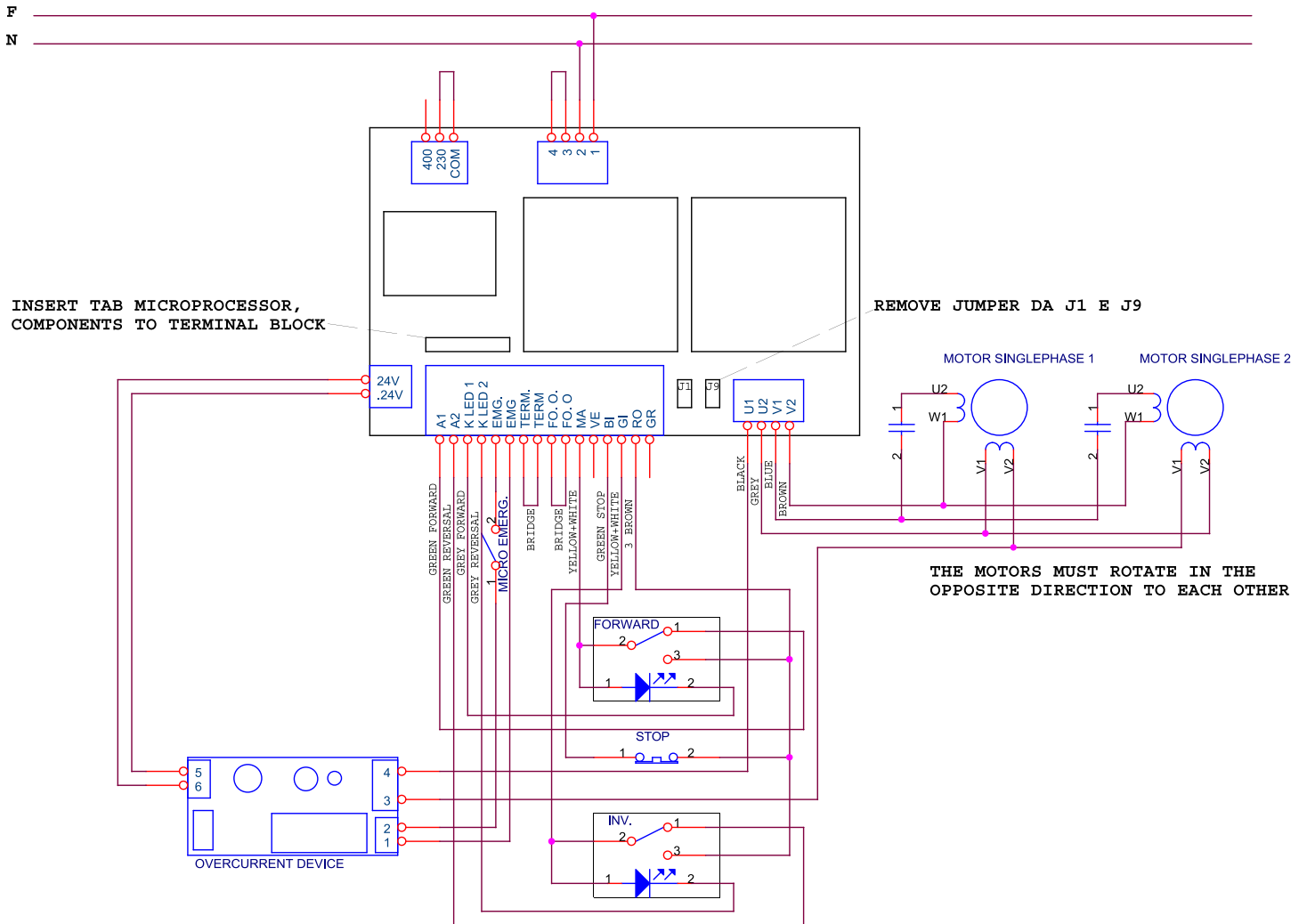

Electrical Schematics

Model MM-IT-0120 37451

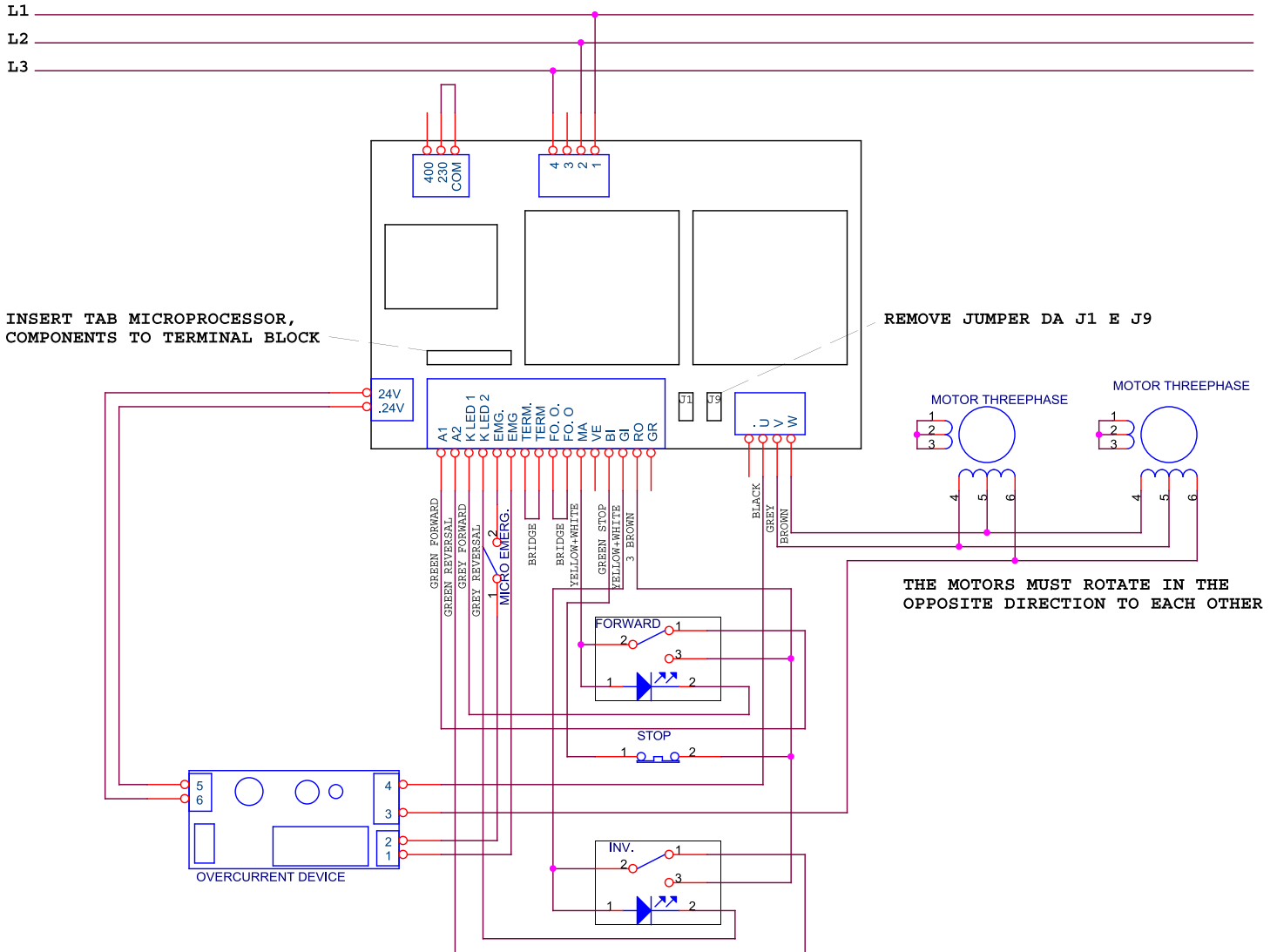



Warranty Registration

Thank you for purchasing an Omcan product. To register your warranty for this product, complete the information below, tear off the card at the perforation and then send to the address specified below. You can also register online by visiting:

Merci d'avoir acheté un produit Omcan. Pour enregistrer votre garantie pour ce produit, complétez les informations ci-dessous, détachez la carte au niveau de la perforation, puis l'envoyer à l'adresse spécifiée ci-dessous. Vous pouvez également vous inscrire en ligne en visitant:

Gracias por comprar un producto Omcan usted. Para registrar su garantía para este producto, complete la información a continuación, cortar la tarjeta en la perforación y luego enviarlo a la dirección indicada a continuación. También puede registrarse en línea en:

<https://omcan.com/warranty-registration/>

For mailing in Canada

Pour postale au Canada

Por correo en Canadá

OMCAN

PRODUCT WARRANTY REGISTRATION

3115 Pepper Mill Court,

Mississauga, Ontario

Canada, L5L 4X5

For mailing in the US

Pour diffusion aux États-Unis

Por correo en los EE.UU.

OMCAN

PRODUCT WARRANTY REGISTRATION

4450 Witmer Industrial Estates, Unit 4,

Niagara Falls, New York

USA, 14305

or email to: service@omcan.com



Purchaser's Information

Name: _____

Address: _____

City: _____ Province or State: _____ Postal or Zip: _____

Country: _____

Dealer from which Purchased: _____

Dealer City: _____ Dealer Province or State: _____

Invoice: _____

Model Name: _____ Model Number: _____

Machine Description: _____

Date of Purchase (MM/DD/YYYY): _____

Would you like to extend the warranty? Yes No

Company Name: _____

Telephone: _____

Email Address: _____

Type of Company:

Restaurant Bakery Deli

Butcher Supermarket Caterer

Institution (*specify*): _____

Other (*specify*): _____

Serial Number: _____

Date of Installation (MM/DD/YYYY): _____

Thank you for choosing Omcan | Merci d'avoir choisi Omcan | Gracias por elegir Omcan



Since 1951 Omcan has grown to become a leading distributor of equipment and supplies to the North American food service industry. Our success over these many years can be attributed to our commitment to strengthen and develop new and existing relationships with our valued customers and manufacturers. Today with partners in North America, Europe, Asia and South America, we continually work to improve and grow the company. We strive to offer customers exceptional value through our qualified local sales and service representatives who provide convenient access to over 5,000 globally sourced products.

Depuis 1951 Omcan a grandi pour devenir un des “leaders” de la distribution des équipements et matériel pour l’industrie des services alimentaires en Amérique du Nord. Notre succès au cours de ces nombreuses années peut être attribué à notre engagement à renforcer et à développer de nouvelles et existantes relations avec nos clients et les fabricants de valeur. Aujourd’hui avec des partenaires en Amérique du Nord, Europe, Asie et Amérique du Sud, nous travaillons continuellement à améliorer et développer l’entreprise. Nous nous efforçons d’offrir à nos clients une valeur exceptionnelle grâce à nos ventes locales qualifiées et des représentants de service qui offrent un accès facile à plus de 5000 produits provenant du monde entier.

Desde 1951 Omcan ha crecido hasta convertirse en un líder en la distribución de equipos y suministros de alimentos en América del Norte industria de servicios. Nuestro éxito en estos años se puede atribuir a nuestro compromiso de fortalecer y desarrollar nuevas relaciones existentes con nuestros valiosos clientes y fabricantes. Hoy con socios de América del Norte, Europa, Asia y América del Sur, que trabajan continuamente para mejorar y crecer la empresa. Nos esforzamos por ofrecer a nuestros clientes valor excepcional a través de nuestro local de ventas y representantes de los servicios que proporcionan un fácil acceso a más de 5,000 productos con origen a nivel mundial.

