



"WE MAKE THE KITCHEN BETTER!"

ATOSA USA, INC.

Toll Free: 855-855-0399 Email: info@atosausa.com

www.atosa.com | www.atosausa.com

California, Colorado, Florida, Georgia, Illinois, New Jersey, Ohio, Texas, Washington

Undercounter Freezer with Drawers

MODELS:

AUF27D2

Standard Features

- Stainless steel exterior & interior with reinforced stainless steel top
- Environmentally friendly R290 refrigerant
- Electronic temperature controller
- Maintains temperatures between -8°F – 1°F
- Recessed door handle(s)
- Magnetic drawer gasket(s)
- Top drawer accommodates 1 full size 12" x 20" x 6" and 3 - 1/6 size 6" deep pans - pans included
- Bottom drawer accommodates 1 full size 12" x 20" x 6" pan - pan included
- Pre-installed 2" heavy duty plate casters



AUF27D2

Optional Accessories

- Extended warranty up to 5 years
- 1" Low profile plate casters available
- 3", 4", 5" Stem casters available

Part#	Discription	Overall Height	Capacity(lb)
R06001000228	1.2 Inch Swivel Plate Caster(without break)	1 7/8"	220
R06001000229	1.2 Inch Swivel Plate Caster(with break)	1 7/8"	220
R06001000006	2 Inch Swivel Plate Caster(without break)	2 7/8"	140
R06001000008	2 Inch Swivel Plate Caster(with break)	2 7/8"	140
R060010000015	3 Inch Swivel Plate Caster Heavy Duty(without break)	3 1/8"	550
R060010000016	3 Inch Swivel Plate Caster heavy Duty(with break)	3 1/8"	550
R06001000058	3.5 Inch Swivel Plate Caster(without break)	4 5/8"	220
R06001000014	3.5 Inch Swivel Plate Caster(with break)	4 5/8"	220
R06001000010	4 Inch Swivel M14 Stem Caster(without break)	4 7/8"	220
R06001000011	4 Inch Swivel M14 Stem Caster(with break)	4 7/8"	220
R06001000002	5 Inch Swivel Stem Caster(without break)	6"	330
R06001000004	5 Inch Swivel Stem Caster(with break)	6"	330

For the best results of food preservation we recommend setting your freezer between -8°F to 0°F

1. Don't forget to leave the unit some room to breathe!
2. Please clean the condenser frequently to give the unit more fresh air.



2 YEAR PARTS AND LABOR WARRANTY
5 YEAR COMPRESSOR PART WARRANTY





"WE MAKE THE KITCHEN BETTER!"

ATOSA USA, INC.

Toll Free: 855-855-0399 Email: info@atosausa.com

www.atosa.com | www.atosausa.com

California, Colorado, Florida, Georgia, Illinois,

New Jersey, Ohio, Texas, Washington

SPECIFICATIONS

Models	Drawers	Capacity (Cu.Ft.)	Casters (inch)	Amps (A)	Voltage (V/Hz/Ph)	HP	Refrigerant	Exterior Dimensions (inch)	Net Weight (lb)	Gross Weight (lb)
AUF27D2	2	6.5	2	3.9	115/60/1	1/5+	R290	27 ^{1/2} ×30×32 ^{1/2}	172	205

PLAN VIEW

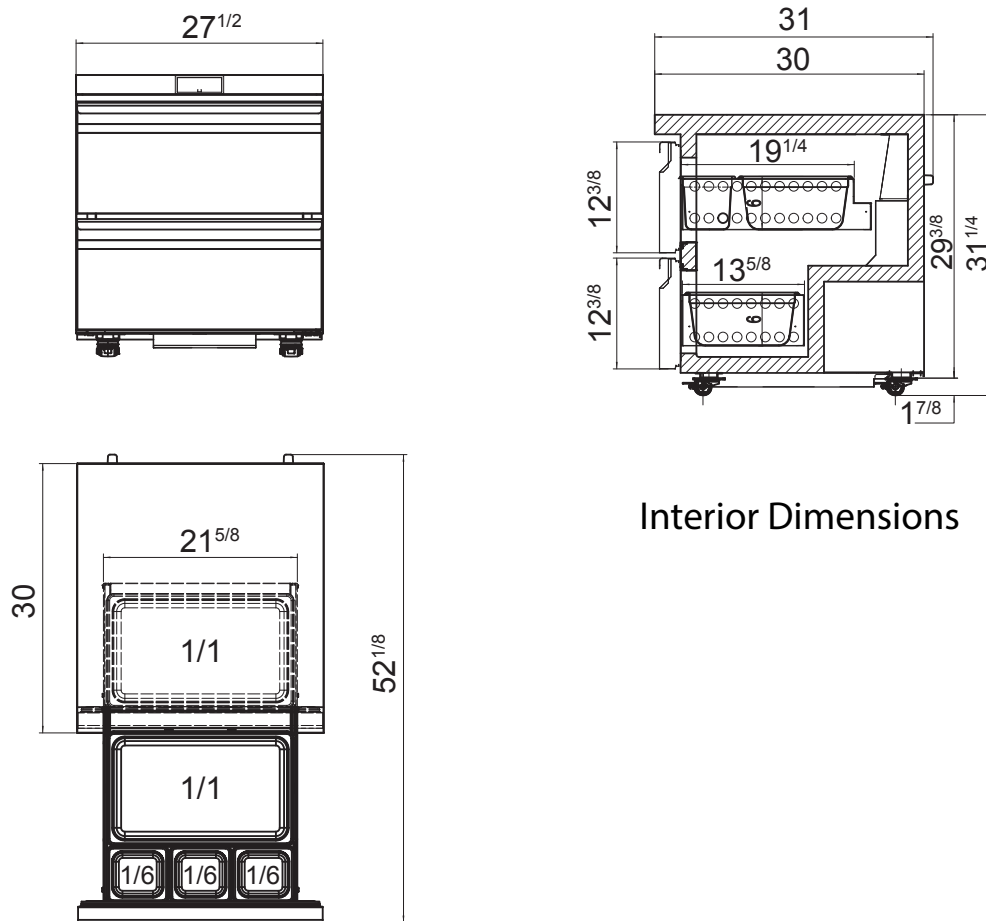

Interior Dimensions

Casters



Rear grate



Temperature control

