

TECHNICAL SPECIFICATION

Features	44" 3 Pan	58" 4 Pan	72" 5 Pan
Item	49020	49021	48790
Model	FW-CN-0003-C	FW-CN-0004-C	FW-CN-0005-C
Max Temperature	203°F (95°C)		
Pan Type	Full Size GN		
Pan Capacity	3	4	5
Power	4000 W		
Amperage	16.7 A		
Electricals	240 V / 60Hz / 1 Ph		
Net Dimensions (WDH)	44" x 32" x 35" (1118 x 811 x 888 mm)	58" x 32" x 35" (1472 x 811 x 888 mm)	72" x 32" x 35" (1828 x 811 x 888 mm)
Shipping Dimensions (WDH)	45" x 32" x 36" (1148 x 890 x 900 mm)	59" x 35" x 36" (1504 x 890 x 900 mm)	74" x 35" x 36" (1860 x 890 x 900 mm)
Net Weight	132 lb (60 kg)	165 lb (75 kg)	200 lb (91 kg)
Shipping Weight	194 lb (88 kg)	247 lb (112 kg)	301 lb (137 kg)

ACCESSORIES (For GN pans, please see last page)

Item	44" 3 Pan	58" 4 Pan	72" 5 Pan
Roll Top Cover	81124		
Sneeze Guard	47022	47023	47024
Overshelf	47018	47019	47020



Dimensions rounded up to the nearest tenth inch or millimeter.
Specifications subject to change without notice.

TECHNICAL DRAWING (49020)

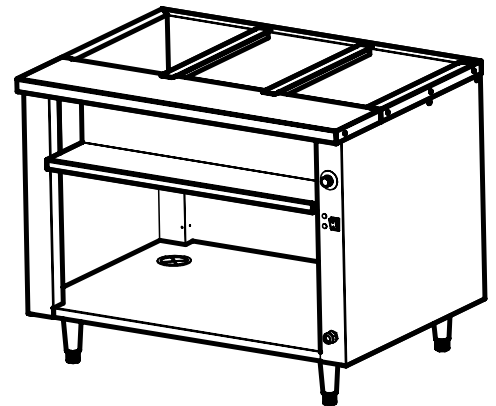
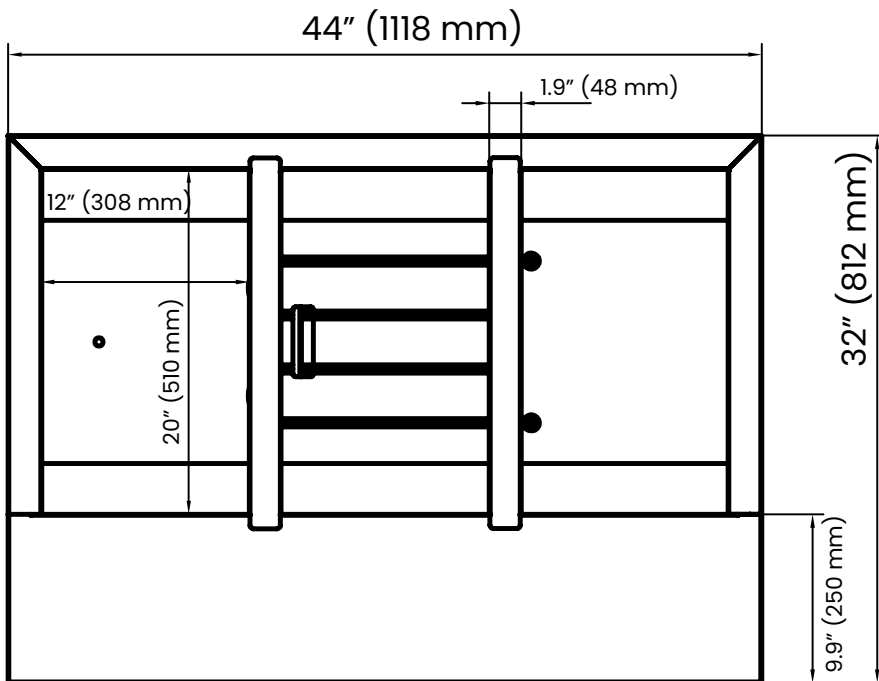
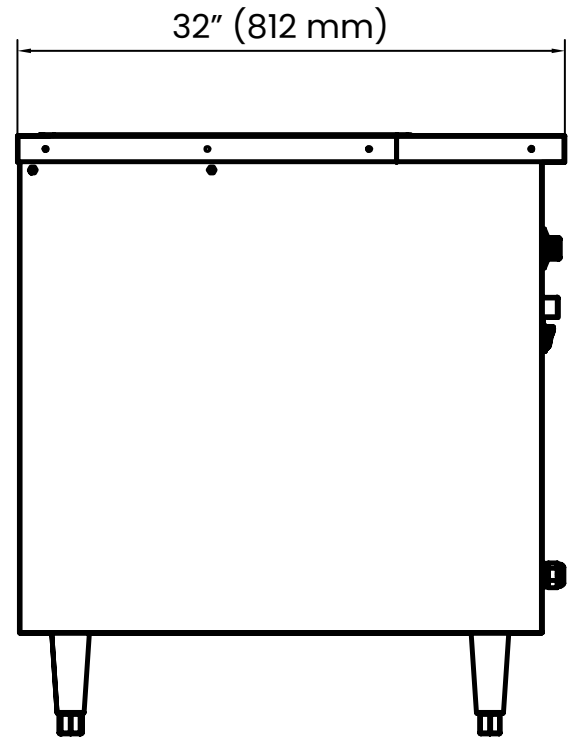
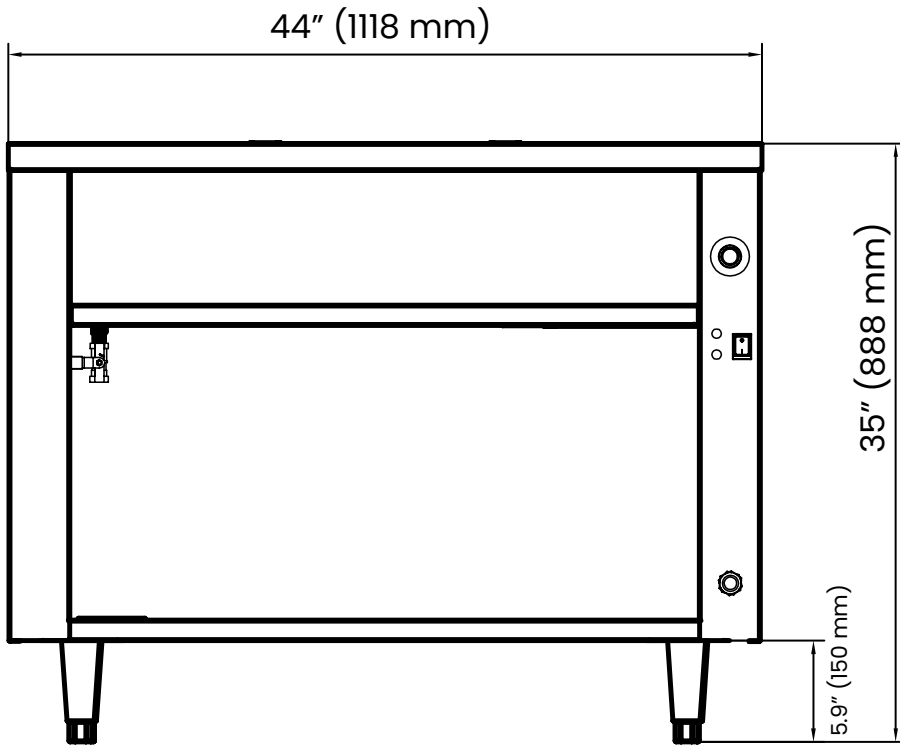

TECHNICAL DRAWING (49021)

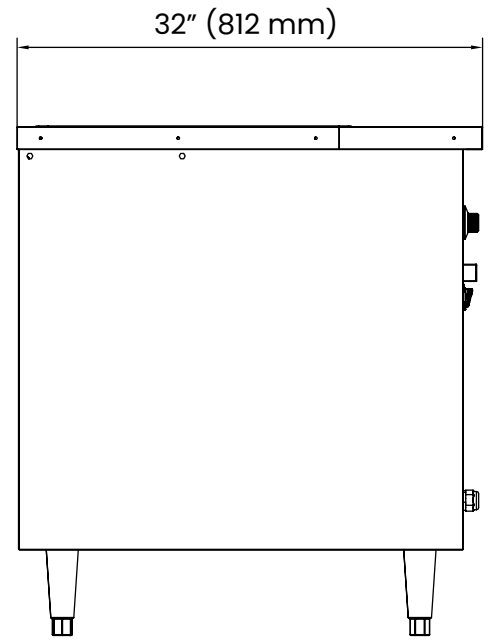
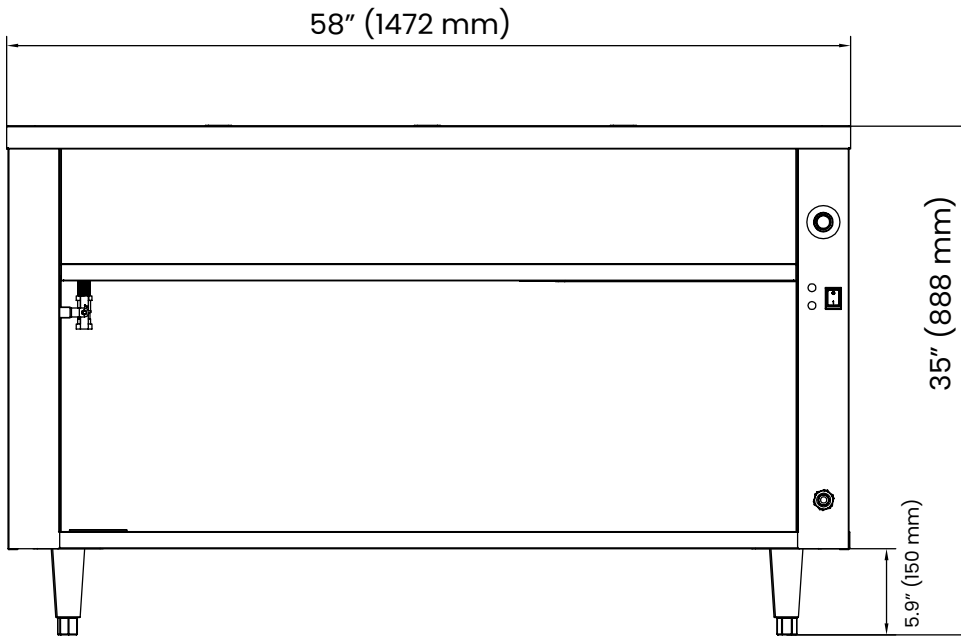

58" (1472 mm)

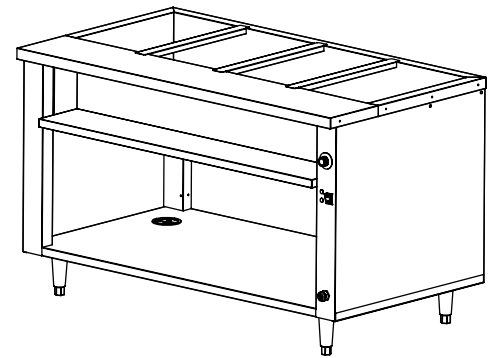
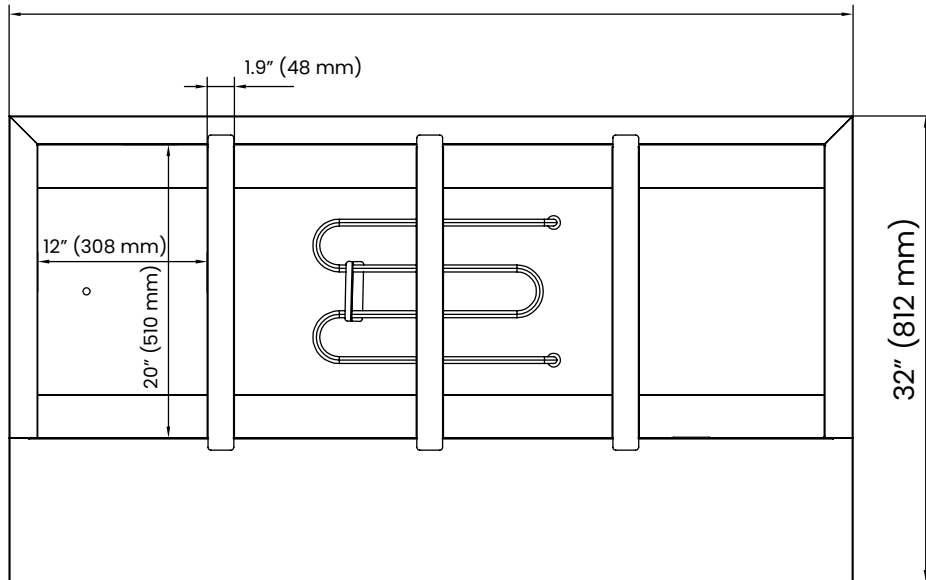

TECHNICAL DRAWING (48790)

