

# Grab-and-Go Open Refrigerated Floor Display Case, Silver

SKU: 51000-176      51000-177

## Showcase your products with style and convenient access using Zanduco's Refrigerated Floor Display Case.

This open refrigerated display is thoughtfully designed to optimize space, making it an excellent choice for cafes, restaurants, supermarkets, and convenient stores. The open-front design allows customers to easily reach items, encouraging impulse purchases and enhancing the overall shopping experience. A pull-down night curtain helps lower energy usage during non-operating hours.

Bright internal LED lighting improves product visibility while highlighting the unit's sleek, modern design. Additional features include a digital temperature controller for accurate cooling, adjustable shelving for versatile merchandising, and casters for smooth and easy mobility. The unit is insulated with an XPS foaming agent to boost energy efficiency and maintain consistent internal temperatures.



### FEATURES:

- Pull-down night curtain for energy savings during off-hours
- Digital temperature controller for precise cooling control
- Bright LED lighting to enhance product visibility
- Adjustable shelves for flexible product arrangement
- Casters for smooth and easy mobility

Made in China

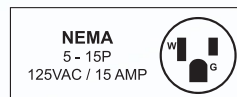

TECHNICAL SPECIFICATION		
SKU	51000-176	51000-177
Capacity	230L   8.12 cu.ft.	380L   13.42 cu.ft.
Power	1130W	1230W
Current	11A	12.1A
Lamp Power (W)	5.8W	10W
Electrical	110V / 60Hz / 1Ph	
Temperature Range	2°C - 10°C   35.6°F - 50°F	
Refrigerant	R290	
Injection	143g	
Electrical Heating Element	450W	
Foaming Agent	XPS	
Shelf Size	19.6" x 9.8"   498 x 250 mm 19.6" x 11.8"   498 x 300 mm 19.6" x 13.8"   498 x 350 mm	35" x 10"   898 x 250 mm 35" x 12"   898 x 300 mm 35" x 14"   898 x 350 mm
Interior Dimensions	21" x 25.6" x 35" 542 x 652 x 884 mm	37" x 25.6" x 35" 942 x 652 x 884 mm
Plug Type	NEMA 5-15P	
Net Dimensions (WDH)	24" x 34.5" x 60.1" 600 x 890 x 1520 mm	39.4" x 35" x 60" 1000 x 890 x 1520 mm
Net Weight	202.8 lb.   82 kg.	246.9 lb.   111 kg.
Gross Dimensions (WDH)	37" x 26" x 67" 940 x 661 x 1702 mm	42" x 37" x 67" 1067 x 940 x 1702 mm
Gross Weight	225 lb.   102 kg.	293 lb.   133 kg.



## FEATURES



Temperature



LED Lighting



Caster

## TECHNICAL DRAWING

51000-176

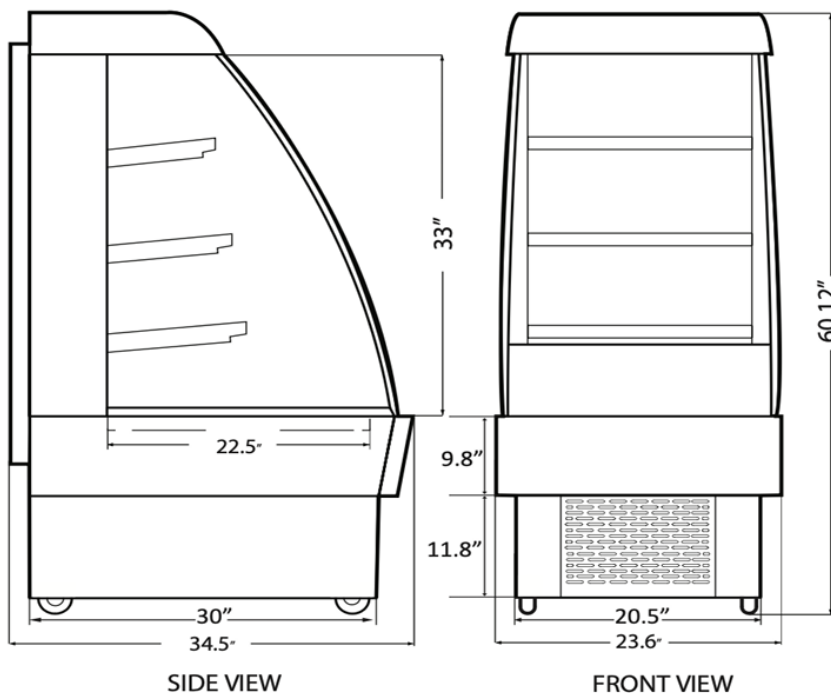

51000-177

