

Convotherm maxx pro

high definition



Combi Oven
Convotherm maxx pro

Table-top models
Operating Manual UL, USA - Original, ENG

Advancing Your Ambitions

FOR THE INSTALLER, OPERATOR, RESPONSIBLE OWNER

FOR YOUR SAFETY

Do not store or use gasoline or other flammable vapors or liquids in the vicinity of this or any other unit.



WARNING

Improper installation, adjustment, alteration, service or maintenance can cause property damage, injury and death. Read the installation, operating and maintenance instructions thoroughly before installing or servicing this equipment.



WARNING

Disconnect power at the main external power switch before servicing or repairing a combi oven.



WARNING

To reduce the risk of electric shock, do not remove or open cover. No user serviceable parts inside. Refer servicing to qualified personnel. Disconnect power supply before servicing.

AVERTISSEMENT

Afin de réduire le risque d'électrocution, ne pas retirer ou ouvrir le capot. Aucune pièce réparabile ne se trouve à l'intérieur. Confier le dépannage à du personnel qualifié. Débrancher l'alimentation électrique avant réparation.

IMPORTANT

IT IS COMPULSORY TO POST INSTRUCTIONS WHICH ARE TO BE FOLLOWED IN THE EVENT THE USER SMELLS GAS. THESE INSTRUCTIONS MUST BE LOCATED IN A PROMINENT LOCATION, AND BE FULLY UNDERSTOOD BY ALL USERS OF THIS EQUIPMENT. THIS INFORMATION NEED TO BE OBTAINED FROM YOUR LOCAL GAS SUPPLIER.

ALL SERVICE MUST BE PERFORMED BY A QUALIFIED CONVOTHERM-BRAND AUTHORIZED TECHNICIAN.

KEEP AREA FREE AND CLEAR OF COMBUSTIBLES.

Installation

- Installation of this unit must be done by a licensed professional when installed in the Commonwealth of Massachusetts.
- The wiring diagram is located on the inner part of the side panel.

Customer documentation

- The customer documentation is part of the combi oven.
- Keep the customer documentation manuals handy at all times so that you can look up any required information.
- Keep the customer documentation manuals for the entire life of the unit.
- Carefully read the installation manual, the operating manual, and the operating instructions before using, handling, and working on this unit.
- If you transfer the combi oven to a new owner, make sure to give the new owner the customer documentation manuals as well.

Table of Contents

1	General	7
1.1	Environmental Protection	7
1.2	Identifying Your Combi Oven	7
1.3	Customer Documentation Structure	10
1.4	About This Operating manual	10
1.5	Safety Information That Must Be Read without Exception	10
2	Configuration and Functions	12
2.1	The Combi Oven's Functions	12
2.2	The Combi Oven's Configuration and Functions	13
2.3	Operating Panel Layout and Functions	16
3	For Your Safety	17
3.1	Basic Safety Instructions	17
3.2	Your Combi Oven's Intended Use	17
3.3	Warning Labels on the Combi Oven	19
3.4	General hazards	20
3.5	Hazards posed by the unit	22
3.6	Safety Devices	27
3.7	Staff and Work Area Requirements	28
3.8	Personal protective equipment	29
4	How to Cook with Your Combi Oven	31
4.1	Basic Guidelines for Putting Food Into the Combi Oven	31
4.1.1	Placing Bakeware Inside the Unit	31
4.1.2	Combi Oven Loading Capacity	32
4.2	Instructions on how to proceed with cooking	33
4.2.1	Turning the Combi Oven On and Off (Lighting Instructions)	33
4.2.2	How to Cook with the ConvoSense Assistance System	34
4.2.3	Cooking Procedures	36
4.2.4	Smoking Procedures	38
4.3	Specific Cooking Instructions	42
4.3.1	Safely Opening and Closing the Unit Door	42
4.3.2	Placing Food Inside and Taking It Out (Standard Model)	43
4.3.3	Placing Food Inside and Taking It Out (Bakery Model)	44
4.3.4	Putting Away and Removing the Core Temperature Probe	46
4.3.5	Using the external core temperature probe or sous vide probe	46
4.3.6	Using a USB Stick	48
4.3.7	Removing and Installing the Racks	50
4.3.8	Filling the Smoker Box, Placing It Inside the Unit, and Removing It from the Unit (ConvoSmoke Only)	53
5	How to Clean the Combi Oven	56
5.1	Combi Oven Cleaning Basics	56
5.1.1	Cleaning Methods	56
5.1.2	Cleaning Agent Delivery for Fully Automatic Cleaning Processes	58
5.1.3	Cleaning schedule	59
5.1.4	Cleaning agents	61
5.1.5	Supplying Cleaning Agents	62
5.2	Fully automatic cleaning process instructions	63
5.2.1	How to Fully Automatically Clean the Oven Cavity Using Canisters	63

Table of Contents

5.2.2	How to Fully Automatically Clean the Oven Cavity Using the Single-dose Dispensing Bottle	64
5.2.3	How to Clean the Oven Cavity Without Using Cleaning Agents	67
5.2.4	How to clean the oven cavity using only rinse aid from connected canisters (easyTouch only)	68
5.2.5	How to clean the oven cavity using only rinse aid from single-dose dispensing bottles (easyTouch only)	69
5.3	General Operator-Aided Cleaning Process Instructions	70
5.3.1	How to Semi-Automatically Clean the Oven Cavity	70
5.3.2	How to Clean the Oven Cavity Section Behind the Suction Panel	72
5.3.3	How to Clean the Triple Glazing Door's Inner Panes and LED Strip	73
5.3.4	How to Clean the Hygienic Plug-In Gasket Thoroughly	74
5.4	Specific Cleaning Instructions	75
5.4.1	Release the suction panel and lock it back in place	75
5.4.2	Removing and Installing the Hygienic Plug-In Gasket	77
5.4.3	Releasing and locking the triple glazing door's inner pane and center pane	78
5.4.4	Emptying and Cleaning the Grease Collection Canister (ConvoGrill Only)	81
5.4.5	Replacing the rinse aid and cleaning agent canisters	82
5.4.6	Adding Cleaning Agent from Single-Measure Dispensing Bottles to the Inside of the Oven Cavity	84
6	How to Perform Maintenance on the Combi Oven	86
6.1	Maintenance Basics	86
6.1.1	Contact Customer Service	86
6.1.2	Warranty information	86
6.1.3	Maintenance Schedule	86
6.2	Troubleshooting	87
6.2.1	Error codes	87
6.2.2	Emergency Mode	89
6.2.3	Problems During Operation	92
6.3	Maintenance Work	94
6.3.1	Replacing the hygienic removable gasket	94

1 General

1.1 Environmental Protection

Policy statement

Our customers' expectations, the legal regulations and standards we have to follow, and our company's reputation are what drives the quality and service behind all our products.

Our environmental management policy is not only designed to ensure that we are always in full compliance with all environmental laws and regulations, but also reflects our commitment to the environment and to continuously improving our performance in this field.

In order to ensure that we meet all of our environmental goals while maintaining the high quality of our products, and that things stay this way, we have developed a quality and environmental management system.

This system meets the requirements set forth in ISO 9001:2015 and ISO 14001:2015.

Environmental protection measures

The following measures apply to this product:

- Uses fully compostable packing products
- Uses RoHS-compliant products
- Complies with the REACH regulation
- Recommends and uses biodegradable cleaning agents
- E-waste recycling
- Environmentally friendly disposal of old units through the manufacturer

Join us in our commitment to protecting the environment!

1.2 Identifying Your Combi Oven

Nameplate location

The nameplate is found on the left side of the combi oven.

Nameplate layout and structure for electrical units

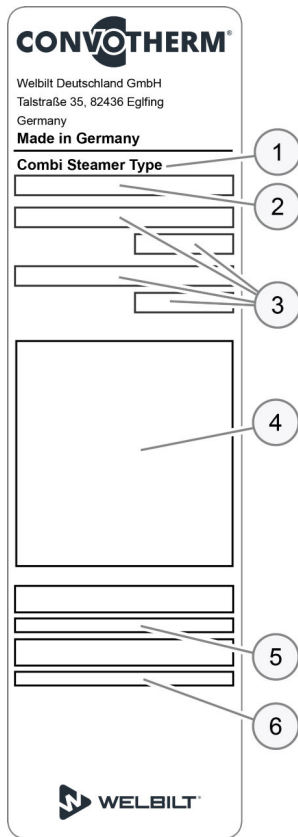

No.	Designation	
1	Unit name Combi Steamer	
2	Trade name	
	Letters	Meaning
	C4	Convotherm maxx pro line of units
	eT	easyTouch controls
	eD	easyDial controls
	xx.yy numbers	Unit size
	EB	Electrical units with boiler
	ES	Electrical units with water injection
	-N	On units with NSF certification
3	Electrical specifications	
4	Marks	
5	Serial number	
	Letters	Meaning
	Heating method	Electrical unit (V)
	Steam generation method	<ul style="list-style-type: none"> ▪ Sprayer (S) ▪ Boiler (B)
	Unit size	<ul style="list-style-type: none"> ▪ 6.10 (1) ▪ 6.20 (2) ▪ 10.10 (3) ▪ 10.20 (4)
	Year of manufacture	<ul style="list-style-type: none"> ▪ 2023 (23) ▪ 2024 (24) ▪ ...
	Month of manufacture	<ul style="list-style-type: none"> ▪ January (01) ▪ February (02) ▪ March (03) ▪ ...
	Consecutive number	4-digit
6	Item number	

Nameplate layout and structure for gas units

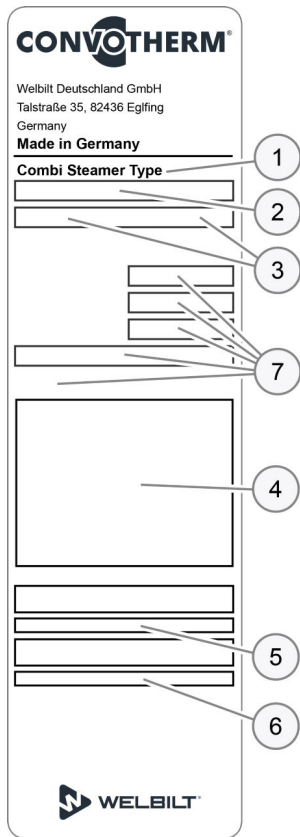

No.	Designation	
1	Unit name Combi Steamer	
2	Trade name	
	Letters	Meaning
	C4	Convotherm maxx pro line of units
	eT	easyTouch controls
	eD	easyDial controls
	xx.yy numbers	Unit size
	GB	Gas unit with boiler
	GS	Gas unit with water injection
	-N	On units with NSF certification
3	Electrical specifications	
4	Marks	
5	Serial number	
	Letters	Meaning
	Heating method	Gas unit (W)
	Steam generation method	<ul style="list-style-type: none"> ▪ Sprayer (S) ▪ Boiler (B)
	Unit size	<ul style="list-style-type: none"> ▪ 6.10 (1) ▪ 6.20 (2) ▪ 10.10 (3) ▪ 10.20 (4)
	Year of manufacture	<ul style="list-style-type: none"> ▪ 2023 (23) ▪ 2024 (24) ▪ ...
	Month of manufacture	<ul style="list-style-type: none"> ▪ January (01) ▪ February (02) ▪ March (03) ▪ ...
	Consecutive number	4-digit
6	Item number	
7	Gas specifications	

1.3 Customer Documentation Structure

Unit documentation parts

Document type	Contents
Installation manual	<ul style="list-style-type: none">▪ Describes how to transport, set up, install, and put the unit into operation▪ Goes over all the hazards involved in the various installation activities and how to prevent and/or counter them▪ Contains technical specifications
Operating manual	<ul style="list-style-type: none">▪ Describes the work sequences and operating steps when cooking and cleaning▪ Includes the maintenance schedule and troubleshooting information▪ Goes over all the hazards involved when operating the unit and how to prevent and/or counter them
Operating instructions	<ul style="list-style-type: none">▪ Describes the unit's user interface▪ Includes the instructions for using the software

Documentation for accessories

For information on how to use accessories (e.g., recoil hand shower, hood, stand on casters, stacking kit), please refer to the corresponding instructions for accessories.

1.4 About This Operating manual

Target groups

Name of target group	Tasks
Storemanager Person authorized to give orders in the kitchen area	<ul style="list-style-type: none">▪ Is responsible for instructing all other users on how to safely and correctly operate, clean, and maintain the unit.▪ Is also responsible for ensuring that the unit is ready for operation before use.
Cook	Primarily takes care of organizational tasks, such as: <ul style="list-style-type: none">▪ Entering cooking profile data▪ Editing existing cooking profiles in the cookbook▪ Coming up with new cooking profiles▪ Configuring the unit's settings and takes care of all operator tasks as well if necessary.
Operator	Actually operates the combi oven, taking care of tasks such as: <ul style="list-style-type: none">▪ Putting food into the combi oven▪ Starting cooking profiles▪ Taking out the food once it has been cooked▪ Cleaning the combi oven▪ Limited maintenance work

Decimal mark used

In order to ensure that all numbers can be properly understood internationally, a decimal point is always used.

1.5 Safety Information That Must Be Read without Exception

Safety information found in the documentation for the customer

Only the installation manual and operating manual provide safety information for the combi oven.

The installation manual provides safety information for the transportation, setup, installation, placing-into-operation, and removal-from-service tasks it describes.

The operating manual provides safety information for the cooking, cleaning, and maintenance tasks it describes.

When using the operating instructions, the operating manual or installation manual should always be consulted in order to obtain the relevant safety information. When performing activities that go beyond simply using the software, the safety information in the operating manual and installation manual must always be observed.

Parts of this document that must be read without exception

Failure to take the information in this document into account may result in death, injury, or property damage.

In order to ensure their safety and the safety of others, everyone working with/on the combi oven must read and understand the following parts of this document before starting any work:

- The section 'For Your Safety' on page 17
- The sections describing the work that will be carried out

Danger symbol



Danger symbol	Meaning
----------------------	----------------



Used to warn of potential injury. Observe all the precautionary statements following this symbol in order to avoid injury or death.

Precautionary statements

The precautionary statements in this manual are categorized using the following hazard levels:

Hazard level	Consequences	Likelihood
 DANGER	Death / severe injury (irreversible)	Imminent
 WARNING	Death / severe injury (irreversible)	Potential
 CAUTION	Minor injury (reversible)	Potential
NOTICE	Property damage	Potential

2 Configuration and Functions

2.1 The Combi Oven's Functions

The Cooking Methods

Your combi oven can be used to cook a variety of food, To do this, the combi oven can be run in any of the following cooking modes:

- Steam
- Combi-steam
- Hot air
- Smoker (optional)

Standard cooking methods

By using the individual cooking mode together with the HumidityPro, Crisp&Tasty, Fan speed, and BakePro extra functions, you can do the following, for example:

- | | | |
|--------------|----------------------|----------------|
| ▪ Boiling | ▪ Steaming | ▪ Stewing |
| ▪ Blanching | ▪ Poaching | ▪ Braising |
| ▪ Roasting | ▪ Broiling | ▪ Baking |
| ▪ Scalloping | ▪ Cooking au gratin | ▪ Thawing food |
| ▪ Preserving | ▪ Smoking (optional) | |

Rethermalization operating mode

You can use 'rethermalization' mode to rethermalize a variety of food. To do this, the combi oven can be run in any of the following cooking modes:

- à la Carte rethermalization
- Banquet rethermalization (with easyTouch only)
- Plate rethermalization (with easyTouch only)

Press&Go operating mode (with easyTouch only)

In 'Press&Go' mode, operators work with predefined cooking profiles that they can select and start automatically.

ConvoSense operating mode (with easyTouch only, optional)

In 'ConvoSense' mode, operators work with predefined cooking profiles that the assistance system directly recognizes when food is being loaded and then cooks fully automatically.

Cooking profiles and cookbook

A cooking profile is a combination of cooking parameters, such as cooking temperature and cooking time. You can create your own cooking profiles and manage them in the 'Cookbook'. In addition, the 'Cookbook' also comes with predefined cooking profiles.

Oven cleaning with easyTouch

There are two cleaning systems available for cleaning the oven:

- ConvoClean+ fully automatic cleaning:
 - any combination of four cleaning levels, three cleaning durations, and the extra 'steam disinfection' and 'drying' functions
 - Oven cleaning without using cleaning agents, rinsing with water
 - Oven cleaning with ConvoCare rinse aid only
- Semi-automatic oven cleaning

Oven cleaning with easyDial

- There are two cleaning systems available for cleaning the oven:
- ConvoClean fully automatic cleaning:
 - Eight cleaning profiles for varying levels of soiling available, with some of them including steam disinfection and drying
 - Oven cleaning without using cleaning agents, rinsing with water
 - Semi-automatic oven cleaning

2.2 The Combi Oven's Configuration and Functions

Parts and functions (electrical units)

The figure below shows a size 6.10 combi oven used as an example representing all electrical models:

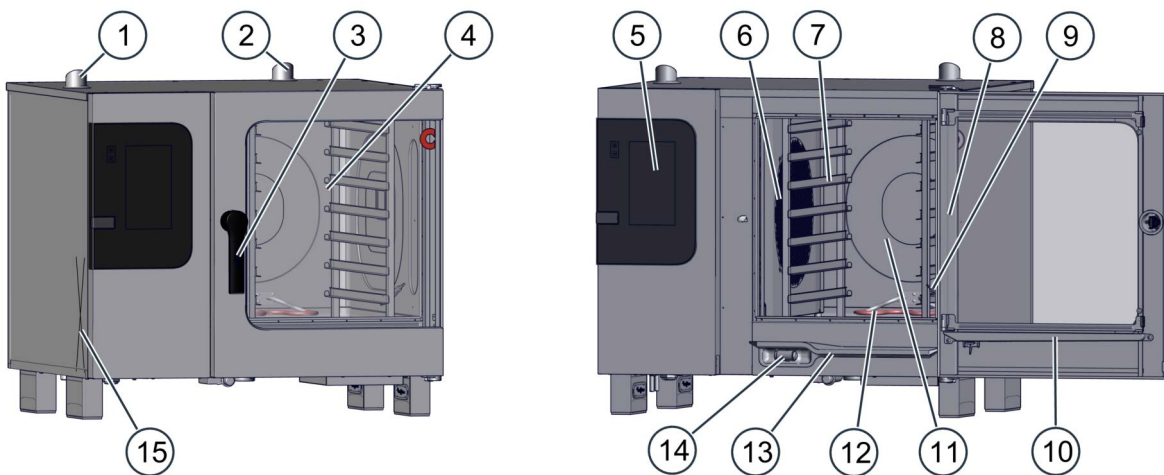

No.	Designation	Function
1	Ventilation port	<ul style="list-style-type: none"> ▪ Draws in ambient air in order to remove moisture from the oven cavity ▪ Compensates for pressure fluctuations inside the oven cavity
2	Air vent	Lets hot steam escape
3	Door handle	<ul style="list-style-type: none"> ▪ Used to open and close the unit door ▪ Cracked-open position for safely opening the unit ('safety lock') ▪ Closing-shut function ▪ Antibacterial material with silver ions ("HygieniCare")
4	Unit door	<ul style="list-style-type: none"> ▪ Seals the oven cavity ▪ When opened, it can be slid backwards along the unit's side in order to save space ('disappearing door') (optional)
5	Operating panel	<ul style="list-style-type: none"> ▪ Used to operate the unit ▪ Antibacterial ("HygieniCare")
6	Suction panel	<ul style="list-style-type: none"> ▪ Used to distribute heat uniformly within the oven cavity ▪ Separates the fan compartment from the oven cavity
7	Rack	Used to hold standard-size bakeware
8	Oven light	<ul style="list-style-type: none"> ▪ Illuminates the oven cavity ▪ Program-controlled
9	Core temperature probe, sous vide probe (optional)	<ul style="list-style-type: none"> ▪ Used to measure the food's internal temperature ▪ Available as an internal version that is permanently connected inside the oven and/or as an external version that can be temporarily connected

No.	Designation	Function
10	Door drip tray	Collects the condensate that runs down the inside of the unit door
11	Oven cavity	Is where food is placed while it is being cooked
12	Smoker heater (ConvoSmoke only)	Used to heat the smoker drawer
13	Unit drip tray	Collects liquids and condensate dripping from the oven cavity
14	Recoil hand shower (not included in certain units)	<ul style="list-style-type: none"> ▪ Meant exclusively for rinsing the oven cavity with water ▪ Is retracted automatically into its holder after being used ▪ Antibacterial ("HygieniCare")
15	Nameplate	Used to identify the unit
16	Camera (not shown)	Recognizes the food to be cooked together with the ConvoSense assistance system (optional)

Parts and functions (gas units)

The figure below shows a size 6.10 combi oven used as an example representing all gas models:

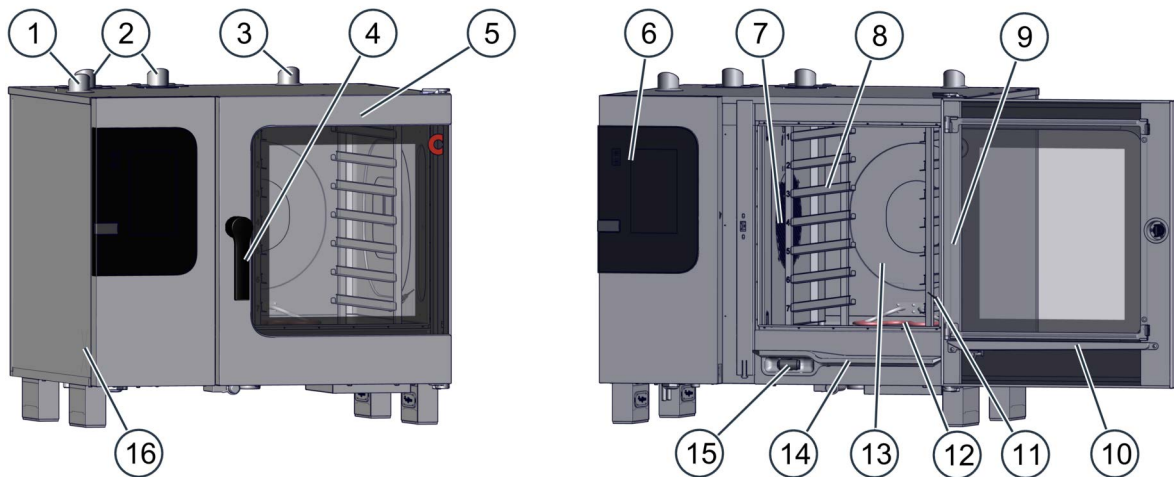

No.	Designation	Function
1	Ventilation port	<ul style="list-style-type: none"> ▪ Draws in ambient air in order to remove moisture from the oven cavity ▪ Compensates for pressure fluctuations inside the oven cavity
2	Exhaust outlet	Discharges hot exhaust gases
3	Air vent	Lets hot steam escape
4	Door handle	<ul style="list-style-type: none"> ▪ Used to open and close the unit door ▪ Cracked-open position for safely opening the unit ('safety lock') ▪ Closing-shut function ▪ Antibacterial material with silver ions ("HygieniCare")
5	Unit door	<ul style="list-style-type: none"> ▪ Seals the oven cavity ▪ When opened, it can be slid backwards along the unit's side in order to save space ('disappearing door')
6	Operating panel	<ul style="list-style-type: none"> ▪ Used to operate the unit ▪ Antibacterial ("HygieniCare")
7	Suction panel	<ul style="list-style-type: none"> ▪ Used to distribute heat uniformly within the oven cavity ▪ Separates the fan compartment from the oven cavity
8	Rack	Used to hold standard-size bakeware
9	Oven light	<ul style="list-style-type: none"> ▪ Illuminates the oven cavity ▪ Program-controlled
10	Door drip tray	Collects the condensate that runs down the inside of the unit door

No.	Designation	Function
11	Core temperature probe, sous vide probe (optional)	<ul style="list-style-type: none"> Used to measure the food's internal temperature Available as an internal version that is permanently connected inside the oven and/or as an external version that can be temporarily connected
12	Smoker heater (ConvoSmoke only)	Used to heat the smoker drawer
13	Oven cavity	Is where food is placed while it is being cooked
14	Unit drip tray	Collects liquids and condensate dripping from the oven cavity
15	Recoil hand shower (not included in certain units)	<ul style="list-style-type: none"> Meant exclusively for rinsing the oven cavity with water Is retracted automatically into its holder after being used Antibacterial ("HygieniCare")
16	Nameplate	Used to identify the unit

Parts and functions for special locking feature (security model only)

The figure below shows a special locking feature for enhanced security on a size 6.10 combi oven used as an example representing all unit sizes:

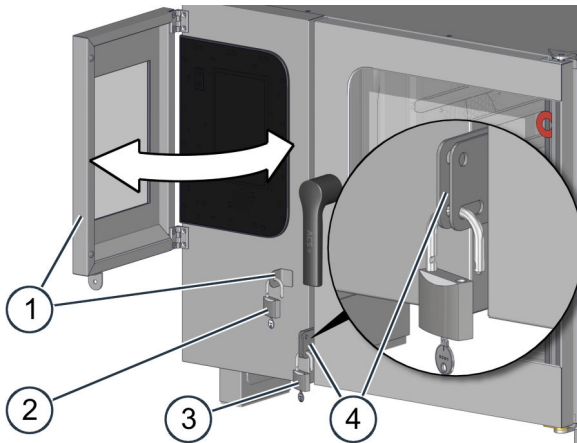

No.	Designation	Function
1	Lockable operating panel cover	The cover can be swung in and secured onto the unit case so that it covers the operating panel, preventing unauthorized users from operating the combi oven.
2	Padlock	<ul style="list-style-type: none"> Used to secure the operating panel cover onto the unit case Not included
3	Padlock	<ul style="list-style-type: none"> Used to secure the unit door onto the unit case Not included
4	Unit door hasp	<p>Features two different slots that can be used to lock the unit door in order to prevent unauthorized users from opening and closing it</p> <p>Unit door action:</p> <ul style="list-style-type: none"> If the unit door is locked using the upper slot, the door will always be fully closed. If the unit door is locked using the lower slot, it will be possible to open the door all the way to the cracked-open position

2.3 Operating Panel Layout and Functions

Control panel layout and parts in easyTouch

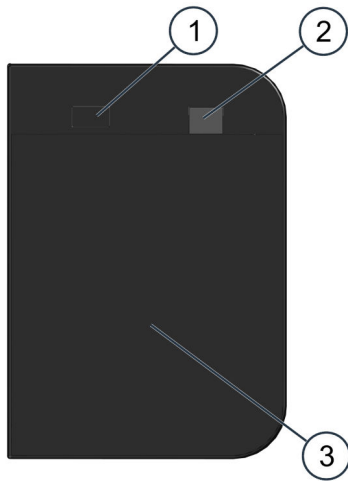

No.	Designation	Function
1	Unit ON/OFF switch	Used to turn the combi oven on and off
2	USB port	Used to plug in a USB stick
3	Full-touch display	The unit's central control interface <ul style="list-style-type: none"> ▪ Used by touching the icons on the full-touch display ▪ Status indicators

Operating panel layout and parts in easyDial

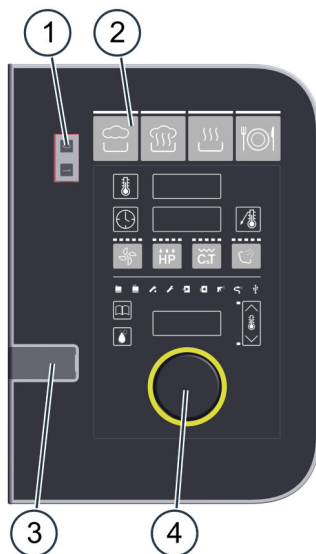

No.	Designation	Function
1	Unit ON/OFF switch	Used to turn the combi oven on and off
2	Control panel	The unit's central control interface <ul style="list-style-type: none"> ▪ Buttons used to enter cooking programs ▪ Displays used to indicate configured values ▪ Prompt indicators for the operator
3	USB port	Used to plug in a USB stick
4	C-Dial	Used to set cooking parameters by turning and pressing the encoder.

3 For Your Safety

Purpose of this section

The purpose of this section is to provide you with all the information you will need in order to safely work with/on the combi oven without putting yourself and others at risk.

Read this section very carefully!

3.1 Basic Safety Instructions

Purpose of these instructions

The purpose of these instructions is to ensure that everyone working with and on the combi oven will be fully aware of all the risks, hazards, and safety requirements involved and will observe the warnings in the operating manual and on the combi oven. Failure to follow these instructions may result in death, injury, or property damage.

Customer documentation manuals

Follow the instructions below:

- Fully read the 'For Your Safety' section, as well as the section that applies to the way you will be interacting with the combi oven.
- Keep the customer documentation manuals handy at all times so that you can look up any required information.
- If you transfer the combi oven to a new owner, make sure to give the new owner the customer documentation manuals as well.

Working with/on the combi oven

Follow the instructions below:

- Only people who meet all the requirements specified in this operating manual should be allowed to use and otherwise work with/on the combi oven.
- Only use the combi oven for its intended use as described in this manual. Never, under any circumstance, use the combi oven for other purposes, even if they seem obvious.
- Observe all the safety measures specified in this operating manual and on the combi oven. This applies especially to wearing the required personal protective equipment.
- Make sure to always stay in the specified work areas when working with/on the combi oven.
- Do not make any alterations to the combi oven. This includes removing components and adding components that have not been expressly approved. Above all, however, make sure not to disable any safety devices or guards.

3.2 Your Combi Oven's Intended Use

The combi oven's intended use

- The combi oven has been designed and built exclusively for cooking a variety of food in standard-size bakeware (steam table pans, sheet pans, etc.). Steam, convection, and combi-steam (steam superheated without pressure) are used for this purpose.
- The bakeware can be made of stainless steel, ceramic, plastic, aluminum, enameled steel, or glass. Glass bakeware must not be damaged.
- The combi oven is intended exclusively for professional commercial use.

Limitations on use

The combi oven should not be used to heat up the following materials:

- Dry powders or granular products
- Readily flammable substances or objects with a flashpoint lower than 518 °F, such as readily flammable oils, fats, plastics, cleaning agents, and liquids containing alcohol.
- Food in sealed cans

Staff requirements

- The combi oven must be operated exclusively by staff meeting the specified requirements. For the corresponding training and qualifications requirements, please refer to 'Staff and Work Area Requirements' on page 28.
- All staff must be familiar with the risks, hazards, and rules involved in handling heavy loads.

Requirements concerning the combi oven's functional capability

- Do not operate the combi oven unless it has been properly transported, set up, installed, and placed into operation as indicated in the installation manual and the person responsible for placing it into operation has confirmed this.
- The combi oven should only be used if all safety devices and guards are present, working properly, and correctly locked in place.
- All manufacturer specifications concerning how to run and service the combi oven must be observed.
- The load placed inside the combi oven must never exceed the maximum permissible loading weight; please refer to 'Combi Oven Loading Capacity' on page 32.

Requirements concerning the combi oven's surroundings

Required combi oven surroundings

- Ambient temperature between 40°F and 95°F
- No toxic or potentially explosive atmospheres
- Do not use or store gasoline or other flammable vapors, gases, or liquids in the vicinity of a combi oven
- Dry kitchen floor in order to reduce the risk of accidents occurring

Required installation location characteristics

- NO fire alarms or sprinkler system directly above the unit
- NO flammable materials, gases, or liquids above, on, under, or close to the unit

Limitations on use

- When used outdoors, the unit must be protected from rain and wind
- Do NOT shift or move the unit once it has been installed and during operation

Prerequisites for cleaning

- Only use the cleaning agents approved by the manufacturer.
- Only use the cleaning tools specified by the manufacturer; please refer to 'Cleaning schedule' on page 59.
- Do NOT use a pressure washer to clean the unit.
- Do NOT use a water jet to clean the outside of the unit. Do not use the recoil hand shower or an external water jet for anything other than cleaning the oven cavity.
- Do NOT use bases or acids to clean the combi oven and make sure it is not exposed to acid fumes. The only exception is when the oven cavity is descaled by an authorized service company following the manufacturer's instructions.

3.3 Warning Labels on the Combi Oven



Warning label location

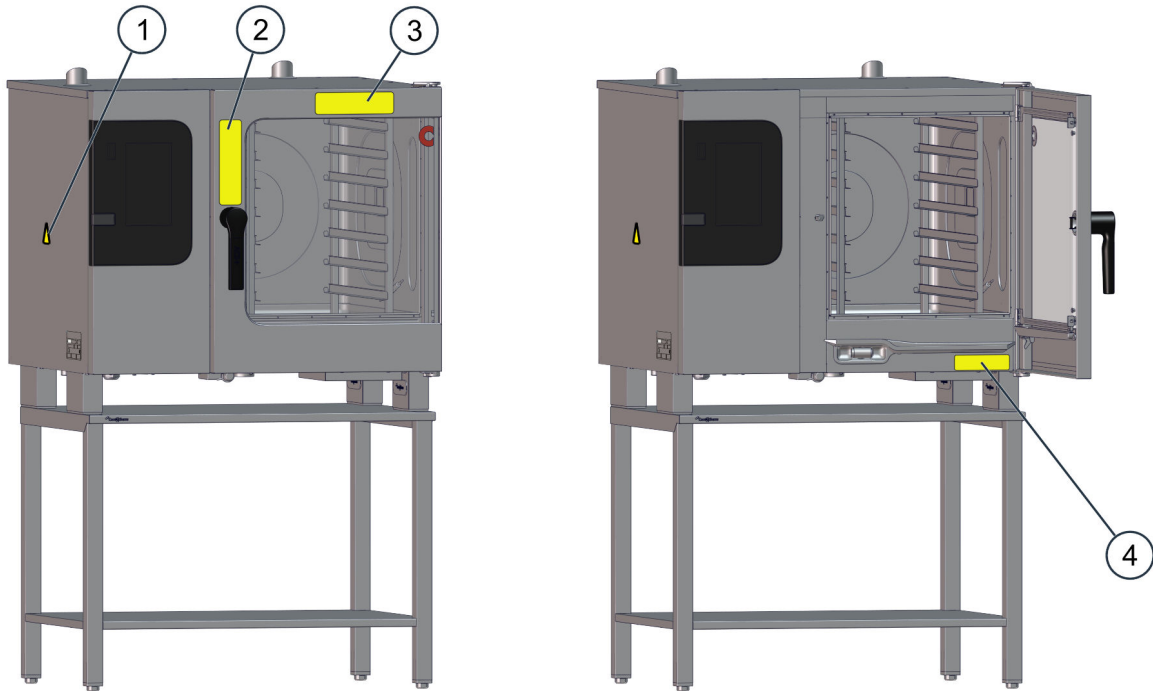



The figure below shows a size 6.10 electric combi oven used as an example representing all table-top models:



Required warning labels

The following warning labels must always be clearly visible on the combi oven at the locations shown in the previous figure.

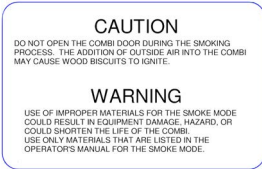
Location	Warning label	Description
1 and 4		<p>WARNING</p> <p>To reduce the risk of electric shock, do not remove or open cover. No user serviceable parts inside. Refer servicing to qualified personnel. Disconnect power supply before servicing.</p> <p>AVERTISSEMENT</p> <p>Afin de réduire le risque d'électrocution, ne pas retirer ou ouvrir le capot. Aucune pièce réparable ne se trouve à l'intérieur. Confier le dépannage à du personnel qualifié. Débrancher l'alimentation électrique avant réparation.</p>
2		<p>Hot steam warning</p> <p>There is a risk of scalding posed by the hot steam coming out when the unit door is opened.</p>
2		<p>Standard model</p> <p>Risk of scalding when liquid food is spilled. This hazard exists when liquids, or food that becomes liquefied during cooking, are placed on the upper shelf levels. Do not use shelf levels located above your field of view to hold liquids or food that will become liquefied.</p>

Location	Warning label	Description
2		Bakery model Hazard posed by hot food and hot bakeware Hot food and hot bakeware will pose a burn hazard if the bakeware falls off the shelf levels or if food slides off bakeware that is being held in an inclined position. This hazard will be particularly acute in the case of shelf levels located above the operator's field of view.
2		Combi oven tip-over hazard warning for when the combi oven is placed on a base with casters There is a risk of the combi oven toppling over when being moved. Exercise extreme caution when moving the combi oven. When moving the combi oven, look out for obstacles and uneven surfaces.
2		Unit connection damage and disconnection warning for when the combi oven is placed on a base with casters There is a risk of the unit's hookups being damaged or disconnected when the combi oven is moved. Exercise extreme caution when moving the combi oven and take the connections' length into account. Every time after moving it, secure the combi oven so that it cannot roll away by accident.
3		Only with ConvoSmoke: CAUTION Do not open combi door during smoking. Outside air entering the combi may cause wood bisquettes to ignite. WARNING The use of improper materials for smoke mode may result in equipment damage or hazards or may shorten the life of the combi. Only use materials listed for smoke mode in the operator's manual.
3		CAUTION Surface(s) and Handle(s) may be hot. ATTENTION Surface(s) et poignée(s) chaudes

3.4 General hazards

General rules for working in the kitchen

Generally speaking, kitchens can pose an extremely wide range of risks and hazards. Accordingly, make sure to always wear the required protective clothing in the kitchen, especially protective gloves when handling kitchenware.

Following is a description of these hazards, their effects, and how they can be avoided.

Spraying into hot fat

Spraying water, such as when using a water jet, can result in the following hazards in the kitchen:



Fat/water mixture explosively spreading everywhere

When?

- Whenever water is sprayed into a container with hot fat, resulting in the water vaporizing abruptly

How can I avoid the hazard?

- ▷ Do not spray water into liquid fat
- ▷ Wear the required personal protective equipment, especially protective gloves

Spraying water on hot surfaces

Spraying water, such as when using a water jet, can result in the following hazards in the kitchen:



Risk of scalding posed by splashing water

When?

- Whenever water is sprayed on hot surfaces, e.g., in an oven cavity

How can I avoid the hazard?

- ▷ Do not spray water on hot surfaces
- ▷ Wear the required personal protective equipment, especially protective gloves

Wet kitchen floors

Wet kitchen floors caused by condensate produced during cooking, for example, can result in the following hazards in the kitchen:



Slip hazard posed by wet kitchen floors

Where?

- In front of the unit

How can I avoid the hazard?

- ▷ Always keep the floor around the unit dry

Risk of poisoning

Gas units can result in the following hazards in the kitchen:



Danger of carbon monoxide poisoning

Where?

- At the unit's installation site

How can I avoid the hazard?

- ▷ Do not block or otherwise obstruct the area below the unit.
- ▷ Operate the unit in windless environments only.
- ▷ Make sure that the installed ventilation equipment works properly and follow all the ventilation rules specified by the gas installation engineer.
- ▷ Arrange for the unit to be serviced once a year.

Contact with cleaning agents

Cleaning agents are used in the kitchen. This can result in the following hazards:



Skin, eye, and respiratory tract irritation hazard as a result of contact with cleaning agents and their vapors

When?

- During all cleaning tasks
- Whenever handling cleaning agent containers
- Whenever using aggressive cleaning agents

How can I avoid the hazard?

- ▷ Wear the required personal protective equipment
- ▷ Do not let your eyes or skin come into contact with cleaning agents
- ▷ Do not inhale the spray mist
- ▷ Use specified cleaning agents only

Moving heavy loads

Lifting heavy loads in the kitchen can result in fatigue, discomfort, and musculoskeletal system issues.



Risk of injury due to excessive exertion

When?

- Whenever lifting heavy containers and other heavy loads

How can I avoid the hazard?

- Follow the rules involved in handling heavy loads

3.5 Hazards posed by the unit

General rules when using the unit

The combi oven has been designed in such a way as to ensure that users will be protected from all hazards that can be reasonably prevented using design-based measures.

However, the combi oven's intended use entails a series of residual risks that will require you to take precautions in order to avoid them. The safety devices and guards on the unit may protect you from some of these risks to a certain extent. However, in order for the safety devices and guards to protect you, you must always make sure that they are in place and working properly.

Following is a description of these residual risks and what kinds of hazards they pose.

Danger areas (gas units)

The figure below shows a size 6.10 gas unit as an example representing all models:

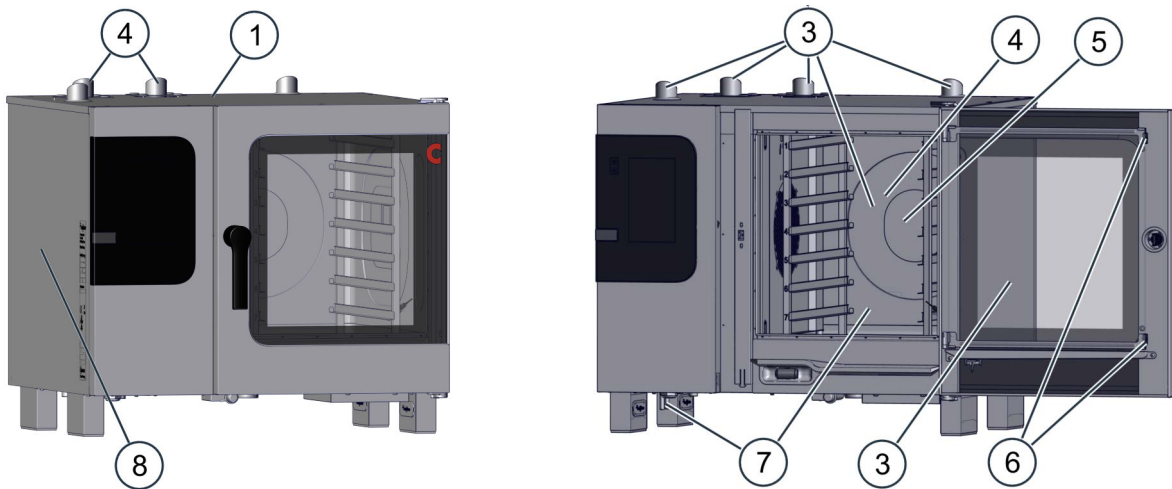

No.	Safety hazard	Location
1	Proximity to flammable materials	On top of the unit
2	Leaking gas (gas units only)	(not shown)
3	Hot surfaces	Air vent, dry air intake, exhaust outlet, unit door, oven cavity
4	Hot steam/vapor	Air vent, dry air intake, oven cavity
5	Hot liquids	Oven cavity
5	Hot food and hot bakeware (bakery model)	Oven cavity
6	Parts moving against each other	Unit door
7	Contact with cleaning agents	Oven cavity, cleaning-agent connection
8	Hosing down the unit with water	Unit case (electrical system cover)

No.	Safety hazard	Location
9	Break in the cold chain	(not shown)
10	Food not fully cooked (only electrical units with ConvoSense)	(not shown)
11	Spoiled food due to microorganism growth in hot environments	(not shown)

Proximity to flammable materials

Heat buildup inside the unit during cooking can result in the following hazards:



Fire hazard posed by the unit's heat loss

When?

- Whenever flammable materials, gases, or liquids are stored on the unit

How can I avoid the hazard?

- ▷ Do not store any flammable materials, gases, or liquids on the unit
- ▷ Do not store any gas canisters next to the unit

Leaking gas during operation

Leaking gas can result in the following hazards when operating the unit:



Gas explosion hazard

When?

- Whenever the unit is moved and this causes leaks in connections
- Whenever the gas line is damaged

How can I avoid the hazard?

- ▷ Do not move the unit during operation or cleaning
- ▷ In the case of units on a base with casters, please refer to the corresponding documentation for accessories
- ▷ If you smell gas, take the appropriate steps; please refer to 'What to do if you smell gas' on page 33

Hot surfaces

The unit's heat buildup during and after cooking can result in the following hazards:



Risk of burns posed by hot surfaces

Where?

- On the outside of the unit door
- On top of the unit, especially at the dry air intake, air vent, and exhaust outlet
- On the inside of the unit door
- Inside the entire oven cavity. This includes all parts that are or have been inside the oven cavity during cooking, such as:

How can I avoid the hazard?

- ▷ Do not touch the surfaces for extended periods of time
- ▷ Wear the required personal protective equipment, especially protective gloves

Hot steam/vapor

Handling the combi oven can result in the following hazards:



Risk of scalding posed by hot steam/vapor

Where? When?

- At the air vent, dry air intake, and exhaust outlet on top of the unit
- Whenever opening the unit door during and after cooking

How can I avoid the hazard?

- ▷ Do not move close to air vents or dry air intakes
- ▷ Always open the unit door slowly and carefully
- ▷ Use the unit door's cracked-open position
- ▷ When cooling down during cooking or cleaning, be ready for a bigger rush of steam than usual and have everyone around step back from the unit
- ▷ Wear the required personal protective equipment, especially protective gloves

Hot liquids

When putting food inside the unit, the following hazards can be posed together with hot liquids:



Risk of scalding posed by hot liquids

When?

- Whenever removing hot, liquid food from the oven

How can I avoid the hazard?

- ▷ Make sure that the racks are correctly locked in place.
- ▷ Do not exceed the maximum load weight
- ▷ Use bakeware (steam table pans) with matching standard dimensions only
- ▷ When handling bakeware containing liquid food or food that will become liquefied during cooking, make sure to only slide the bakeware into fully visible shelf levels, as well as to pull it out in a completely horizontal position
- ▷ Do not place containers with liquids or liquefying food on a baking sheet for cooking
- ▷ Slide the bakeware in correctly as specified in 'Placing Bakeware Inside the Unit' on page 31
- ▷ After removing it from the oven and before taking it anywhere else, cover the bakeware in order to prevent hot liquids from spilling out.
- ▷ Wear the required personal protective equipment, especially protective gloves

Hot food and hot bakeware (bakery model)

The following hazards can be posed when handling bakeware:



Burn hazard posed by hot food and hot bakeware

When?

- Whenever bakeware is placed on L-rails

How can I avoid the hazard?

- ▷ Make sure that the racks are correctly locked in place.
- ▷ Only use bakeware (sheet pans, oven racks) with the right patisserie size
- ▷ Do not exceed the maximum load weight
- ▷ Slide the bakeware in correctly as specified in 'Placing Bakeware Inside the Unit' on page 31
- ▷ When taking out bakeware, take it out in a horizontal position and do not pull it forward too much, as it may topple over
- ▷ Wear the required personal protective equipment, especially protective gloves

Parts moving against each other

Handling the unit can result in the following hazards:



Pinch point hazard (hand hazard)

Where?

- On accessories used to load the unit
- At unit door components during cleaning

How can I avoid the hazard?

- ▷ Wear the required personal protective equipment, especially protective gloves
- ▷ Exercise caution when handling the unit

Contact with cleaning agents

Cleaning the unit can pose the following hazards:



Skin, eye, and respiratory tract irritation hazard as a result of contact with cleaning agents and their vapors

When?

- Whenever the oven cavity is not cooled down sufficiently first
- Whenever the unit door is opened during the fully automatic cleaning sequence
- Whenever cleaning agent canisters are replaced
- Whenever cleaning agent is brought inside the oven cavity
- Whenever cleaning agent is brought inside the oven cavity with single-dose dispensing bottles

How can I avoid the hazard?

- ▷ Before any cleaning work, let the oven cavity cool down to a temperature lower than 140 °F
- ▷ Open the unit door only after being prompted to do so by the software
- ▷ After cleaning, carry out a visual inspection to make sure that all cleaning agent residues have been removed after thorough rinsing
- ▷ Exercise caution when handling cleaning agent canisters, cleaning agent, and single-dose dispensing bottles

Hosing down the unit with water

Cleaning work on the unit can pose the following hazards:



Risk of electric shock due to short circuit

When?

- If the unit comes into contact with water

How can I avoid the hazard?

- ▷ Do not hose down the outer case
- ▷ De-energize the unit when cleaning the outside

Break in the cold chain

A break in the cold chain can pose the following hazards when consuming food:



Risk of microbiological food contamination

When?

- When the cooking process is manually interrupted
- When the food's cold chain is broken by putting the food in the oven cavity prematurely
- When the cooking process is interrupted by a power outage

How can I avoid the hazard?

- ▷ Make sure not break the cold chain
- ▷ Never interrupt cooking for a period that may result in microorganism growth
- ▷ Do not use the oven cavity to temporarily store the food being cooked
- ▷ When cooking at low temperatures, do not place cold food inside
- ▷ Once the unit starts up again, take into account the time that will be necessary to restart the cooking process while taking the food's condition into account

Undercooked food

When cooking with the ConvoSense assistance system, there is always a statistical possibility of faulty food recognition that can result in the following hazards:



Hazard posed by consuming undercooked food

When?

- Whenever the ConvoSense assistance system makes a mistake when recognizing food

How can I avoid the hazard?

- ▷ Check to make sure that the ConvoSense assistance system is working properly
- ▷ Correct the incorrectly recognized cooking profile
- ▷ Clean the camera on the outside
- ▷ Use Press&Go for cooking if necessary
- ▷ Check to make sure that the end product is fit for consumption
- ▷ Exercise the due care required by HACCP

Microorganism growth at 85 – 150 °F

Cooking within a low temperature range can pose the following hazards:



Risk of food spoilage due to microorganism growth at hot ambient conditions (temperature range of 85 - 150 °F)

When?

- Whenever rethermalizing, using low-temperature cooking, or keeping food warm and then proceeding to place cold food in the unit at the same time
- Whenever using low-temperature cooking or keeping food warm in general

How can I avoid the hazard?

- ▷ Do not move cold food into the unit while rethermalizing food, cooking food at low temperatures, or keeping food warm
- ▷ Low-temperature cooking (< 150 °F) should be performed by qualified staff only
- ▷ Reduce the amount of microorganisms on the food before cooking it at low temperatures (by searing it, for example).
- ▷ Check to make sure that the end product is fit for consumption
- ▷ Exercise the due care required by HACCP

3.6 Safety Devices

Meaning

The combi oven features a series of safety devices and guards that protect the user from a variety of hazards. All safety devices and guards must be present, fully functional, and locked properly without exception when the combi oven is being used.

Location and functions

The figure below shows a size 6.10 electric combi oven used as an example representing all table-top models:

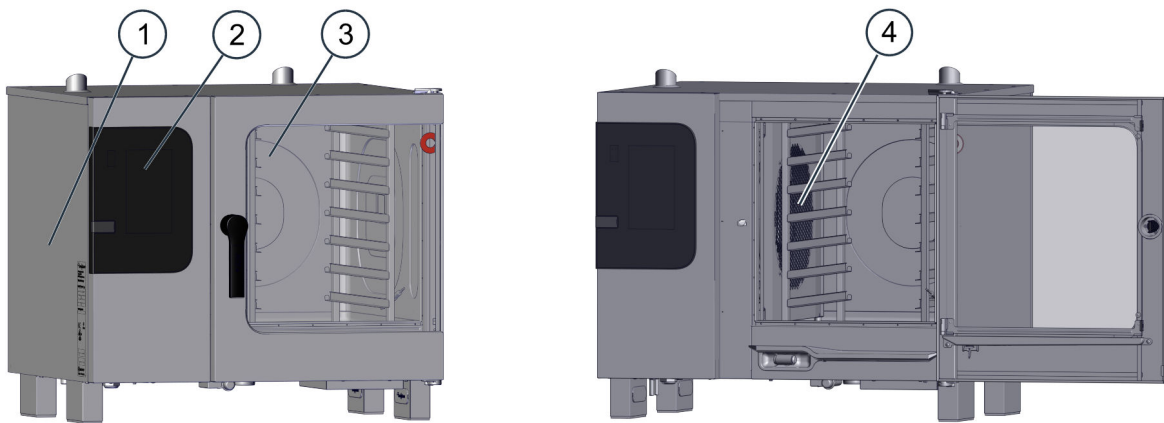

No.	Guard or safety device	Function	Check
1	Cover; can only be removed with tools	<ul style="list-style-type: none"> Prevents staff from accidentally touching live parts Prevents staff from reaching into the moving fan inside the wiring compartment 	Check to make sure that the cover is in its proper place
2	Operating panel; can only be removed with tools	Prevents staff from accidentally touching live parts	Check to make sure that the operating panel is in its proper place
3	Unit door	Protects the operator and the surroundings from hot steam	Check the pane for scratches, cracks, and other damage on a regular basis and replace it if you detect any damage
4	Suction panel inside the oven cavity; can only be removed with tools	Prevents staff from reaching into the moving fan and ensures proper heat distribution	Please refer to 'Releasing the Suction Panel and Locking it Back in Place' on page 75
5 (not shown)	Safety thermostat <ul style="list-style-type: none"> Boiler Oven cavity 	Turns off the unit if the temperature exceeds the allowable limit	An error code will be output in the event of a fault (Contact a service company that is authorized to reset the safety thermostat)

No.	Guard or safety device	Function	Check
6 (installed by the customer)	Disconnecter	Used to de-energize the unit during cleaning, repairs, and maintenance work, as well as in hazardous situations	The operator does not need to check anything
7 (installed by the customer)	Gas shut-off device	Used to disconnect the unit from the gas supply during cleaning, repair, and maintenance work, as well as in hazardous situations.	The operator does not need to check anything

Safety measures

The following measures will contribute to greater safety:

Measure	Function	Check
Unit door solenoid switch (electrical door sensor)	<ul style="list-style-type: none"> ▪ Stops/turns off the following when the unit door is opened: <ul style="list-style-type: none"> ▪ Fan (will stop after a few seconds) ▪ Heating element ▪ Cleaning agent spraying in the fully automatic oven cleaning process ▪ Prompts the user to close the unit door 	Test the door solenoid switch with the combi oven at a low temperature Procedure: <ul style="list-style-type: none"> ▪ Fully open the unit door ▪ Press Start Result: The motor must not start running.
Unit door handle with cracked-open position	<ul style="list-style-type: none"> ▪ Prevents steam coming out from scalding the operator's face and hands 	With the combi oven at a low temperature, check the door positions as described in 'Safely Opening and Closing the Unit Door on page 42.'
Resuming after a power outage if there was cleaning agent inside the unit when the power went out	<ul style="list-style-type: none"> ▪ Starts the fully automatic or semi-automatic oven cleaning process again, from a defined state, after a power outage 	None

3.7 Staff and Work Area Requirements

Staff requirements

The table below specifies the qualifications needed for each role. Provided that they have the required qualifications, a single person can take over more than one role if necessary.

Role	Required qualifications	Tasks
Cook Storemanager Person authorized to give orders in the kitchen area	<ul style="list-style-type: none"> ▪ Has relevant training ▪ Is familiar with all country-specific food and hygiene laws and regulations ▪ Must maintain documentation as required by HACCP ▪ Has been briefed on how to operate the combi oven 	<p>Is the person responsible for the combi oven</p> <p>Primarily takes care of organizational tasks, such as:</p> <ul style="list-style-type: none"> ▪ Entering cooking profile data ▪ Editing existing cooking profiles in the cookbook ▪ Coming up with new cooking profiles ▪ Configuring the unit's settings <p>And takes care of all operator tasks as well if necessary</p>
Operator	<ul style="list-style-type: none"> ▪ Is semi-skilled ▪ Has been briefed on how to operate the combi oven ▪ Works under supervision ▪ Is familiar with the rules involved in handling heavy loads 	<p>Actually operates the combi oven, taking care of tasks such as:</p> <ul style="list-style-type: none"> ▪ Putting food into the combi oven ▪ Starting the cooking profile ▪ Taking out the food once it has been cooked ▪ Cleaning the combi oven ▪ Changing equipment inside the oven cavity if required for specific cooking sequences ▪ Limited maintenance work

Work areas during operation

During operation, the work area for staff is in front of the unit door.

Work areas during cleaning and maintenance

During cleaning and maintenance, the work area for staff is the entire area occupied by the unit and its surroundings.

3.8 Personal protective equipment

Operation and Maintenance

Task	Tools used	Personal Protective Equipment
Placing food inside / taking food out	None	<p>Wear appropriate work clothes for kitchen work as required by your country-specific standards and regulations, especially:</p> <ul style="list-style-type: none"> ▪ Protective clothing ▪ Heat-resistant gloves ▪ Safety footwear
Handling the core temperature probe (option)	None	<p>Wear appropriate work clothes for kitchen work as required by your country-specific standards and regulations, especially:</p> <ul style="list-style-type: none"> ▪ Protective clothing ▪ Heat-resistant gloves
Removing and installing parts	Tools and equipment necessary for the specific task at hand	<p>Wear appropriate work clothes for kitchen work as required by your country-specific standards and regulations, especially:</p> <ul style="list-style-type: none"> ▪ Protective clothing ▪ Heat-resistant gloves

Cleaning

Task	Cleaning agents used	Personal Protective Equipment
Cleaning the oven cavity (all methods) Handling cleaning agent containers	<ul style="list-style-type: none"> ▪ ConvoClean forte ▪ ConvoCare (Ready to use) ▪ ConvoCare Concentrate ▪ ConvoClean forte S ▪ ConvoCare S 	The required protective equipment will depend on the cleaning agents being used and the selected cleaning method, and may include: <ul style="list-style-type: none"> ▪ Respirator ▪ Safety eyewear ▪ Protective gloves ▪ Protective clothing/apron Always follow the instructions and observe all warnings found on the labels used for the cleaning agent(s).
<ul style="list-style-type: none"> ▪ Cleaning the triple glazing door ▪ Cleaning the control panel 	Common household glass cleaner	Observe the cleaning agent manufacturer's instructions and other information
<ul style="list-style-type: none"> ▪ Cleaning the outside of the unit case, incl. the control panel ▪ Cleaning components and accessories as specified in the corresponding instructions 	Common household alkali-free, pH-neutral, odorless dishwashing liquid	Observe the cleaning agent manufacturer's instructions and other information
Cleaning the equipment stand	Common household stainless steel cleaner	Observe the cleaning agent manufacturer's instructions and other information

4 How to Cook with Your Combi Oven

4.1 Basic Guidelines for Putting Food Into the Combi Oven

4.1.1 Placing Bakeware Inside the Unit

Steam table pans; half-size wire shelf, in U-rails (standard model)

The following figure shows how to set up a steam table pan (12" x 20" x X"), two steam table pans (12" x 10" x X"), and a half-size wire shelf (13" x 20") in U-rails (standard model):

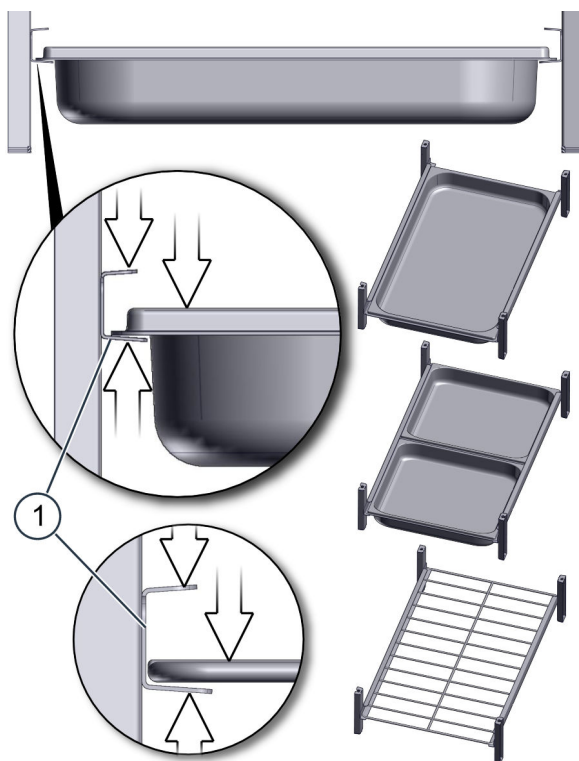

Placement rules

- Bakeware and oven racks must be slid in BETWEEN the two flanges on the U-rails (1) all the way in.
- The bakeware / oven racks must be slid in at the same height on both sides.
- NEVER place bakeware or oven racks on top of a U-rail's upper flange.
- Do not place bakeware on top of shelf grills.

Sheet pans, on L-rails (bakery model)

The following figure shows how to set up a full-size sheet pan (18" x 26") and two half-size sheet pans (13" x 18") on L-rails (bakery model) in a rack in UL models:

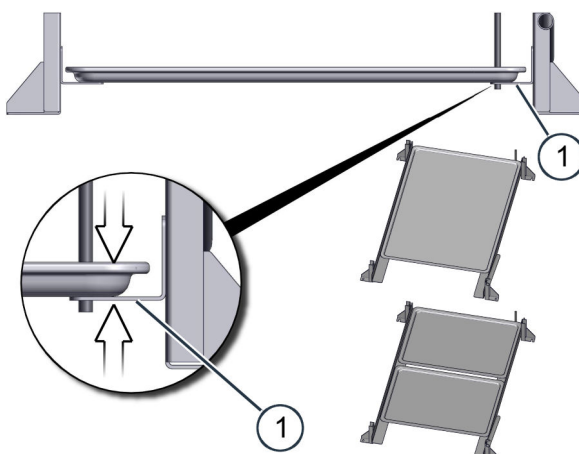

Placement rules

- The sheet pan must be slid all the way in on top of the L-rails (1).
- The sheet pan must be slid in at the same height on both sides.
- Do not put liquids or food that will become liquefied during cooking in the sheet pan.
- The method shown is intended exclusively for sheet pans (and, if applicable, oven racks), NOT for bakeware.
- Do not place bakeware on top of sheet pan.

4.1.2 Combi Oven Loading Capacity

Maximum weight that can be placed inside the combi oven for cooking

C4		6.10	6.20	10.10	10.20
Applies to standard-size bakeware (steam table pans, sheet pans etc.)					
Maximum load weight per unit	[lbs]	66	132	110	220
Maximum load weight per shelf	[lbs]	33	33	33	33

Maximum weight that can be placed inside the combi oven for rethermalizing

C4		6.10	6.20	10.10	10.20
Applies to standard-size bakeware (steam table pans, sheet pans etc.)					
Maximum load weight per unit	[lbs]	20	40	33	66
Maximum load weight per bakeware container (Steam table pan 12"x20"x2.5")	[lbs]	3.3	3.3	3.3	3.3
Applies to plates					
Maximum number of plates per unit	[pcs]	15	27	26	48
Maximum load weight per plate	[oz]	12.7	12.7	12.7	12.7

Maximum number of bakeware containers when cooking and rethermalizing food

C4		6.10	6.20	10.10	10.20
Number of shelves (max. shelf spacing: 2.68")	[pcs]	7	7	11	11
Steam table pans (12" x 20" x 1")	[pcs]	7	14	11	22
Steam table pans (12" x 20" x 2.5")	[pcs]	7	14	11	22
Wire shelves, half size (13"x20")	[pcs]	7	14	11	22
Sheet pans, half size (13"x18") - on wire shelves	[pcs]	6	12	10	20
Frying baskets, half size (12"x20")	[pcs]	7	14	11	22
Plates (optional plate rack)	[pcs]	15	14	26	22

Maximum number of bakeware when smoking

C4 ES / EB		6.10	6.20	10.10	10.20
Number of shelves (max. shelf spacing: 2.68")	[pcs]	7	7	11	11
Steam table pans (12" x 20" x 1")	[pcs]	6	13	10	21
Steam table pans (12" x 20" x 2.5")	[pcs]	6	11	10	19
Wire shelves, half size (13"x20")	[pcs]	7	14	11	22
Sheet pans, half size (13"x18") - on wire shelves	[pcs]	7	14	11	22
Sheet pans, half size (13"x18")	[pcs]	7	-	11	-
Frying baskets, half size (12"x20")	[pcs]	6	13	10	21

During smoking, the bottommost shelf level of the rack must remain free due to the smoker box – do not put anything in it!

4.2 Instructions on how to proceed with cooking

4.2.1 Turning the Combi Oven On and Off (Lighting Instructions)

▲ For your safety when working with/on the combi oven

Before starting work, read and understand the rules, risks, and hazards specified in the 'For Your Safety on page 17' section and in these instructions and follow all the corresponding instructions without exception.

What to do if you smell gas

If you smell gas, follow the steps below without exception:

- Immediately shut off the gas.
- Thoroughly ventilate the room.
- Do not operate any electrical devices or equipment. Make sure not to cause any sparks.
- Evacuate the building.
- Call the gas utility and, if necessary, the fire department on a telephone found outside the hazardous area.

Basic rules for safe operation

If the combi oven is moved in an impermissible manner after installation (on purpose or by accident), do not continue to operate the unit unless all the following requirements are met:

- The unit and the accessories being used do not have any obvious damage.
- The supply lines installed for electrical power, water, wastewater, and cleaning agents do not have any obvious damage, have a secure fit, are not dripping anywhere, and appear to be safe and fully functional after a visual inspection.
- The 'Requirements concerning the combi oven's functional capability on page 18' are being met.
- The 'Requirements concerning the combi oven's surroundings on page 18' are being met.
- All warning labels are at their intended location.

Gas units only:

- A service technician has checked all the components in the combi oven that convey gas in order to make sure that there are no leaks at any of their connection points. Moreover, the technician has checked to make sure that none of the specified points outside and inside the unit have any leaks.

Checks before turning on the unit

Before turning on the combi oven, check whether the prerequisites below are being met. Do not place the unit into operation unless all specified prerequisites are met.

- The unit does not have any obvious damage.
- The accessories being used do not have any obvious damage.
- The installed water connections do not have any obvious damage and are not dripping at any point.
- The drain pipe is connected to the unit and does not have any obvious damage. The end of the drain pipe conveys the wastewater from the unit into the sewer system. The drain pipe is not dripping at any point and there are no indications of it being clogged.
- The electrical connection does not have any obvious damage and looks like it is safe and working properly when subjected to a visual inspection.
- There is nothing being stored inside the oven cavity and there is nothing inside the oven cavity other than required cooking accessories (food containers, for example).
- The 'Requirements concerning the combi oven's functional capability on page 18' are being met.
- The 'Requirements concerning the combi oven's surroundings on page 18' are being met.
- All warning labels are at their intended location.

Gas units only:



- The gas supply line and the system used to remove exhaust gases do not have any obvious damage and look like they are safe and working properly when subjected to a visual inspection.

Rules for safely running the unit

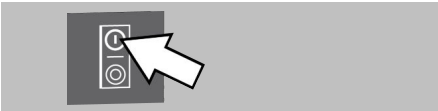
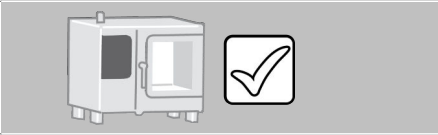

In order to avoid hazards, follow the rules below when running the unit:

- Make sure to only use your hands when using the unit's controls (buttons, switches, touchscreens).
- Do not cover, obstruct, or block the exhaust vents, exhaust outlets, or ventilation ports at the top of the unit or the ventilation openings at the bottom.
- The racks need to be locked in place.
- Bakeware must be slid in properly as indicated in the 'Placing Bakeware Inside the Unit' on page 31 section.
- The suction panel needs to be properly locked in place.

Turning the combi oven on

- | | | |
|----|--|---|
| 1. |  | Turn the combi oven on. |
| 2. |  | Check whether the oven becomes illuminated while the unit is running its self-diagnostic routine. |
| 3. |  | Wait until the software is ready to start working. |

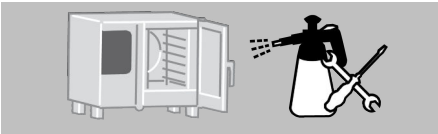
Turning off the combi oven when you are done

- | | | |
|----|---|--|
| 1. |  | Carry out all necessary cleaning work as per the cleaning schedule and maintenance schedule. |
| 2. |  | Turn the combi oven off. |
| 3. |  | Leave the unit door ajar in order to let moisture escape. |

Turning off the combi oven before extended periods of nonuse

Before extended periods of nonuse, disconnect the unit from the water, gas, and power supplies.

4.2.2 How to Cook with the ConvoSense Assistance System

⚠ For your safety when working with/on the combi oven

Before starting work, read and understand the rules, risks, and hazards specified in the 'For Your Safety on page 17' section and in these instructions and follow all the corresponding instructions without exception.

Procedures that you must be familiar with

You will need to be familiar with the following steps:

- Safely Opening and Closing the Unit Door 42
- Placing Food Inside and Taking It Out (Standard Model) 43
- Placing Food Inside and Taking It Out (Bakery Model) 44
- Putting Away and Removing the Core Temperature Probe 46
- Using a USB Stick 48





Rules





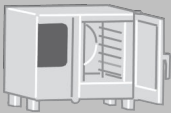

Putting plates inside the combi oven is only allowed when rethermalizing food.

Prerequisites

- You must be familiar with how to use the software to such an extent that you will be able to access the stored cooking profiles you will need for your food or enter a new cooking profile and start it (please refer to the operating instructions).
- The combi oven and the accessories being used must have been cleaned properly.
- There must not be any foreign objects inside the oven cavity.
- The oven cavity drain must be clear. It must not be clogged or blocked by any residues. The strainer on the oven drain must be in place.
- The unit door's inner and center panes must be installed properly.
- The suction panel must be locked in place.
- The USB cover must be covering the USB port.
- If the unit is on top of an open stand: There must not be any hot, steaming food inside the stand.
- The racks have been installed and are locked in place.
- The network connection and the camera must be working.
- You must have the food that will be put inside the combi oven ready to go.

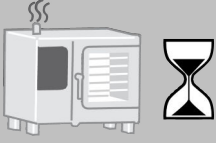
Cooking Procedures

1.		Activate assistance system cooking.
2.		Follow the software's prompts. <ul style="list-style-type: none"> ▪ If the oven cavity is being pre-heated, wait for the pre-heating to end and then continue to step 4. ▪ If the oven cavity is being cooled down, continue to step 3.
3.		<div style="border: 1px solid black; padding: 2px; display: inline-block;">⚠ CAUTION</div> <p>Risk of scalding posed by hot steam</p> <ul style="list-style-type: none"> ▪ Be ready for a bigger rush of steam than usual. ▪ Have everyone around step back from the unit. ▪ Slowly and carefully open the unit door. <p>Open the unit door and wait until the oven has cooled down.</p>
4.		Place the food inside the combi oven.

5.		<p>⚠ WARNING</p> <p>Hazard posed by consuming undercooked food</p> <ul style="list-style-type: none"> ▪ Make sure that the automatic food recognition feature works properly and, if the wrong cooking profile is detected, correct it. ▪ Use Press&Go for cooking if necessary. <p>Make sure that the automatic food recognition feature selects the right cooking profile. If the wrong food is recognized, correct it.</p>
6.		<p>Close the unit door. Result: The cooking sequence will start automatically.</p>
7.		<p>Wait until the cooking sequence is done.</p>
8.		<p>Once the cooking sequence is done, the unit will make a sound to let you know. Follow the software's prompts.</p>
9.		<p>Open the unit door.</p>
10.		<p>⚠ WARNING</p> <p>Hazard posed by consuming undercooked food</p> <ul style="list-style-type: none"> ▪ Check the cooked food before providing it for consumption. ▪ Exercise the due care required by HACCP. <ul style="list-style-type: none"> ▪ Take out the food. ▪ Check the cooked food.
11.		<p>Close the unit door.</p>

4.2.3 Cooking Procedures

⚠ For your safety when working with/on the combi oven

Before starting work, read and understand the rules, risks, and hazards specified in the 'For Your Safety on page 17' section and in these instructions and follow all the corresponding instructions without exception.

Procedures that you must be familiar with

You will need to be familiar with the following steps:

- Safely Opening and Closing the Unit Door 42
- Placing Food Inside and Taking It Out (Standard Model) 43
- Placing Food Inside and Taking It Out (Bakery Model) 44
- Putting Away and Removing the Core Temperature Probe 46
- Using a USB Stick 48





Rules



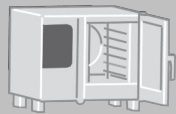

Putting plates inside the combi oven is only allowed when rethermalizing food.

Prerequisites

- You must be familiar with how to use the software to such an extent that you will be able to access the stored cooking profiles you will need for your food or enter a new cooking profile and start it (please refer to the operating instructions).
- The combi oven and the accessories being used must have been cleaned properly.
- There must not be any foreign objects inside the oven cavity.
- The oven cavity drain must be clear. It must not be clogged or blocked by any residues. The strainer on the oven drain must be in place.
- The unit door's inner and center panes must be installed properly.
- The suction panel must be locked in place.
- The USB cover must be covering the USB port.
- When using a ConvoGrill: The grease collection canister must be empty and connected to the combi oven.
- If the unit is on top of an open stand: There must not be any hot, steaming food inside the stand.
- The racks have been installed and are locked in place.
- You must have the food that will be put inside the combi oven ready to go.

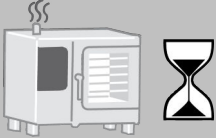
Cooking Procedures

1.		Open a cooking profile from the cookbook or enter a new cooking profile. Start the cooking sequence.
2.		Follow the software's prompts. <ul style="list-style-type: none"> ▪ If the oven cavity is being pre-heated, wait for the pre-heating to end and then continue to step 4. ▪ If the oven cavity is being cooled down, continue to step 3.
3.		<div style="border: 1px solid black; padding: 2px; display: inline-block;">⚠ CAUTION</div> <p>Risk of scalding posed by hot steam</p> <ul style="list-style-type: none"> ▪ Be ready for a bigger rush of steam than usual. ▪ Have everyone around step back from the unit. ▪ Slowly and carefully open the unit door. <p>Open the unit door and wait until the oven has cooled down.</p>
4.		Place the food inside the combi oven.
5.		Close the unit door.

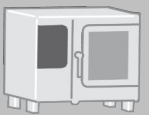
6		Start the cooking sequence.
7.		Wait until the cooking sequence is done.
8.		Once the cooking sequence is done, the unit will make a sound to let you know. Follow the software's prompts.
9.		Open the unit door.
10.		Take out the food.
11.		Close the unit door.

4.2.4 Smoking Procedures

▲ For your safety when working with/on the combi oven

Before starting work, read and understand the rules, risks, and hazards specified in the 'For Your Safety on page 17' section and in these instructions and follow all the corresponding instructions without exception.

Procedures that you must be familiar with

You will need to be familiar with the following steps:

- Placing Food Inside and Taking It Out (Standard Model) 43
- Using a USB Stick 48
- Filling the Smoker Box, Placing It Inside the Unit, and Removing It from the Unit (ConvoSmoke Only) 53







Rules





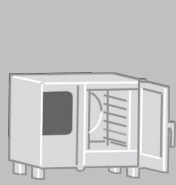
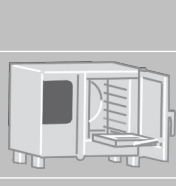

Putting plates inside the combi oven is only allowed when rethermalizing food.

Prerequisites



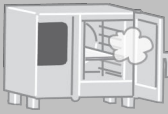

- You must be familiar with how to use the software well enough so that you will be able to access the stored cooking profiles you will need for your food or enter a new cooking profile for smoking and start it. (see operating instructions).
- The combi oven and the accessories being used must have been cleaned properly.
- There must not be any foreign objects inside the oven cavity.
- The oven drain must be clear. It must not be clogged or blocked by any residues.
- The unit door's inner and center panes must be installed properly.
- The smoker drawer must be properly filled and ready to go.
- The ventilation system must be running
- The suction panel must be locked in place.
- The USB cover must be covering the USB port.
- When using a ConvoGrill: The grease collection canister must be empty and connected to the combi oven.
- If the unit is on top of an open stand: There must not be any hot, steaming food inside the stand.
- The racks have been installed and are locked in place.
- You must have the food that will be put inside the combi oven ready to go.









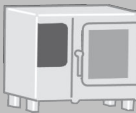

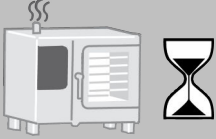
How to smoke food when your cooking profile only includes smoking

1.		Open a cooking profile from the cookbook or enter a new cooking profile.
2.		Follow the software's prompts. <ul style="list-style-type: none"> ▪ If the oven cavity is being pre-heated, wait for the pre-heating to end and then continue to step 4. ▪ If the oven cavity is being cooled down, continue to step 3.
3.		<p>⚠ CAUTION</p> <p>Risk of scalding posed by hot steam</p> <ul style="list-style-type: none"> ▪ Be ready for a bigger rush of steam than usual. ▪ Have everyone around step back from the unit. ▪ Slowly and carefully open the unit door. <p>Open the unit door and wait until the oven has cooled down.</p>
4.		Place the smoker box inside.
5.		Place the food inside the combi oven. The bottommost shelf level must remain free due to the smoker box – do not put anything in it!
6.		Close the unit door.
7.		Start the smoking sequence.

8.		<p>⚠ WARNING</p> <p>Risk of burns caused by the ignition of smoking chips, pellets, bisquettes, etc. and smoke; risk of smoke inhalation</p> <ul style="list-style-type: none"> Under no circumstance open the unit door during smoking. <p>Wait until the smoking sequence is done.</p>
9.		<p>Once the smoking sequence is done, the unit will make an acoustic signal to let you know. Follow the software's prompts.</p>
10.		<p>Open the unit door.</p>
11.		<p>Remove the smoked food.</p>
12.		<p>Remove the smoker box.</p>
13.		<p>Close the unit door.</p>

How to smoke food when your cooking profile includes cooking and smoking

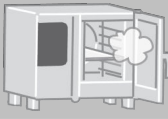
1.		<p>Open a cooking profile from the cookbook or enter a new cooking profile.</p>
2.		<p>Follow the software's prompts.</p> <ul style="list-style-type: none"> If the oven cavity is being pre-heated, wait for the pre-heating to end and then continue to step 4. <p>If the oven cavity is being cooled down, continue to step 3.</p>
3.		<p>⚠ CAUTION</p> <p>Risk of scalding posed by hot steam</p> <ul style="list-style-type: none"> Be ready for a bigger rush of steam than usual. Have everyone around step back from the unit. Slowly and carefully open the unit door. <p>Open the unit door and wait until the oven has cooled down.</p>
4.		<p>Place the food inside the combi oven. The bottommost shelf level must remain free due to the smoker box that will go in later on – do not put anything in it!</p>
5.		<p>Close the unit door.</p>

6.		Start the cooking sequence.
7.		Wait until the cooking sequence is done.
8.		<p>Once the cooking steps before smoking are done, the unit will make an acoustic signal to let you know. Follow the software's prompts:</p> <ul style="list-style-type: none"> ▪ The oven cavity will be cooled down with a 'Cool down' sequence. ▪ You will then be prompted to put the smoker drawer inside.
9.		<p>⚠ CAUTION</p> <p>Risk of scalding posed by hot steam</p> <ul style="list-style-type: none"> ▪ Be ready for a bigger rush of steam than usual. ▪ Have everyone around step back from the unit. ▪ Slowly and carefully open the unit door. <p>Open the unit door and wait until the oven has cooled down.</p>
10.		Place the smoker box inside.
11.		Close the unit door.
12.		Start the smoking sequence.
13.		<p>⚠ WARNING</p> <p>Risk of burns caused by the ignition of smoking chips, pellets, bisquettes, etc. and smoke; risk of smoke inhalation</p> <ul style="list-style-type: none"> ▪ Under no circumstance open the unit door during smoking. <p>Wait until the smoking sequence is done.</p>
14.		<p>Once the smoking sequence is done, the unit will make an acoustic signal to let you know. Follow the software's prompts.</p>
15.		Open the unit door.
16.		Remove the smoked food.

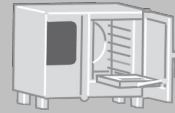
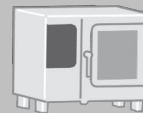
17.		Remove the smoker box.
18.		Close the unit door.

Cleaning the smoker box

The smoker box must be thoroughly cleaned after every use. For more information, please refer to 'Cleaning schedule' on page 59.

4.3 Specific Cooking Instructions

4.3.1 Safely Opening and Closing the Unit Door

⚠ For your safety when working with/on the combi oven

Before starting work, read and understand the rules, risks, and hazards specified in the 'For Your Safety on page 17' section and in these instructions and follow all the corresponding instructions without exception.

Prerequisites

- When placed on top of a work table, the unit must be secured in such a way that it will not slide out of place.

Safely opening the unit door

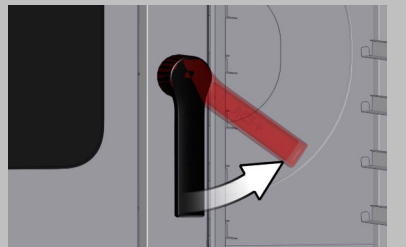
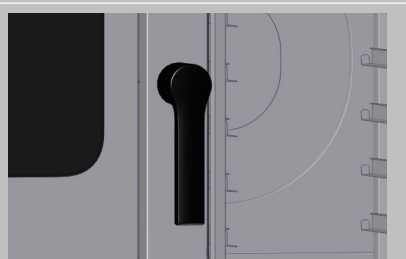
1.		Turn the door handle to the right. Result: The unit door will open into its cracked-open position and the door handle will swing back to its resting position.
2.		⚠ WARNING Risk of scalding posed by hot steam <ul style="list-style-type: none">▪ Always open the unit door slowly and carefully.▪ Always use the unit door's cracked-open position Wait a moment to make sure that all steam is allowed to escape.

3.

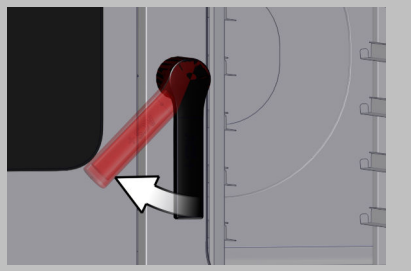

Turn the door handle to the left and open the unit door slowly.

4.

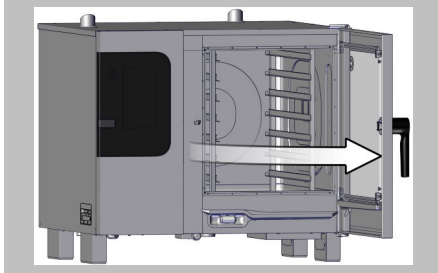

On units with a right-hinged door:
Fully open the unit door.

On units with a disappearing door:
Slide the unit door backwards along the combi oven's side.

Safely closing the unit door

On units with a right-hinged door:

- Close the unit door with a little momentum.

On units with a disappearing door:

- Pull the unit door straight towards the front along the combi oven's side and close it with a little momentum.

4.3.2 Placing Food Inside and Taking It Out (Standard Model)

⚠ For your safety when working with/on the combi oven

Before starting work, read and understand the rules, risks, and hazards specified in the 'For Your Safety on page 17' section and in these instructions and follow all the corresponding instructions without exception.

Procedures that you must be familiar with

You will need to be familiar with the following steps:

- Safely Opening and Closing the Unit Door

42

Prerequisites

- The racks have been installed and are locked in place.
- The food's weight must not exceed the maximum loading weight.
- The bakeware must have the right GN dimensions.

Putting food into the combi oven

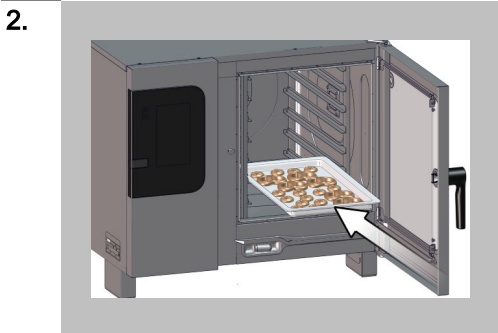
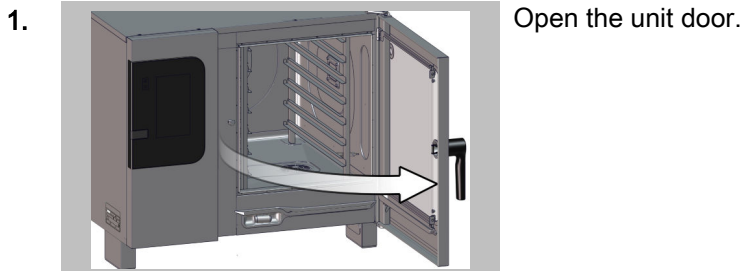

⚠ WARNING

Risk of scalding posed by hot liquids

- Make sure to slide the bakeware, sheet pans, and oven racks correctly into the right rails as specified in 'Placing Bakeware Inside the Unit' on page 31.

Move the food into the shelf levels you want.

- Start from the bottom.
- Always slide bakeware, sheet pans, and shelf grills in all the way to the stop.

Taking food out

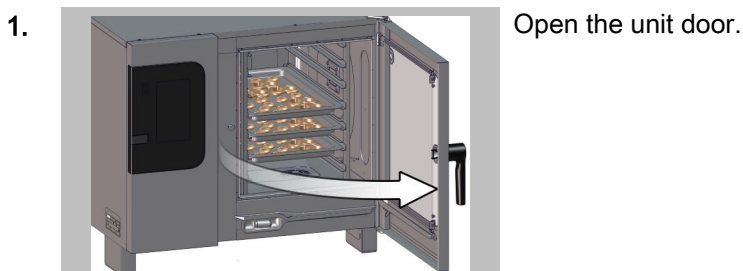

4.3.3 Placing Food Inside and Taking It Out (Bakery Model)

⚠ For your safety when working with/on the combi oven

Before starting work, read and understand the rules, risks, and hazards specified in the 'For Your Safety on page 17' section and in these instructions and follow all the corresponding instructions without exception.

Procedures that you must be familiar with

You will need to be familiar with the following steps:

- Safely Opening and Closing the Unit Door

Prerequisites

- The racks have been installed and are locked in place.
- The food's weight must not exceed the maximum loading weight.
- The bakeware must have the right patisserie dimensions.

Putting food into the combi oven

1.  Open the unit door.

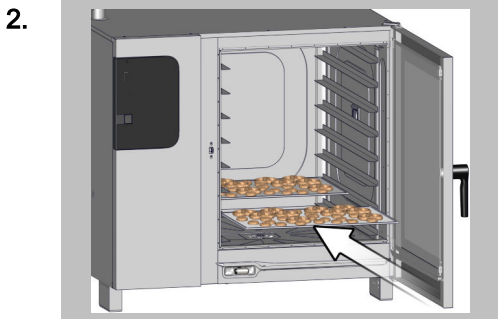

⚠ WARNING

Burn hazard posed by hot food and hot bakeware

- Make sure to slide the sheet pans correctly into the right rails as specified in 'Placing Bakeware Inside the Unit' on page 31.

Move the food into the shelf levels you want.

- Start from the bottom.
- Always slide the sheet pans in all the way to the stop.

Taking food out

1.  Open the unit door.

2.  Take out bakeware in a horizontal position

4.3.4 Putting Away and Removing the Core Temperature Probe

⚠ For your safety when working with/on the combi oven

Before starting work, read and understand the rules, risks, and hazards specified in the 'For Your Safety on page 17' section and in these instructions and follow all the corresponding instructions without exception.

Procedures that you must be familiar with

You will need to be familiar with the following steps:

- Safely Opening and Closing the Unit Door

42

Purpose

If you will not be needing the core temperature probe for the cooking sequence you will be using, make sure to put it away. Not doing so may result in the probe being damaged.

Putting away the core temperature probe

1.

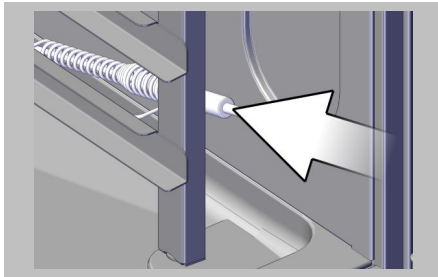

Slide the core temperature probe into the spiral holder on the right-hand side rack.

NOTICE! Pay attention to the cable!

The cable must not get pinched in between the unit door and the hygienic plug-in gasket when the door is closed.

Removing the core temperature probe

1.

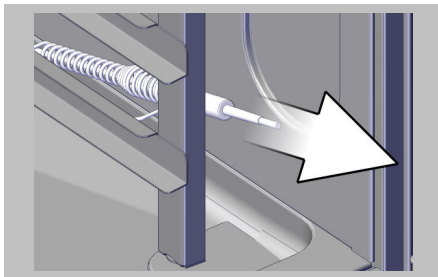

⚠ CAUTION

Risk of stab wounds posed by sharp parts

- Exercise care when handling the core temperature probe.

Pull the core temperature probe out from the holder on the right-hand side rack.

4.3.5 Using the external core temperature probe or sous vide probe

⚠ For your safety when working with/on the combi oven

Before starting work, read and understand the rules, risks, and hazards specified in the 'For Your Safety on page 17' section and in these instructions and follow all the corresponding instructions without exception.

Procedures that you must be familiar with

You will need to be familiar with the following steps:

- Safely Opening and Closing the Unit Door
- Putting Away and Removing the Core Temperature Probe

42

46

How it works

In addition to the internal core temperature probe that is permanently connected inside the oven, you can temporarily connect an additional external core temperature probe or sous vide probe on the outside of the unit case. The internal core temperature probe will be deactivated the moment the external connector is used. In other words, the unit's software will give priority to the external core temperature probe or sous vide probe when cooking. The internal core temperature probe CANNOT be used simultaneously with the external core temperature probe and/or sous vide probe when cooking. Likewise, you will not be able to use the internal core temperature probe when an external core temperature probe or sous vide probe is connected.

Prerequisites

- The external core temperature probe or sous vide probe must have already been cleaned. Moreover, it must be fully functional and ready to go.
- The food being cooked must have already been placed properly inside the oven cavity.

Connecting and using the external core temperature probe or sous vide probe

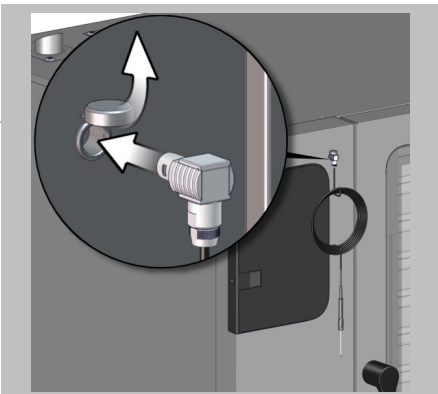
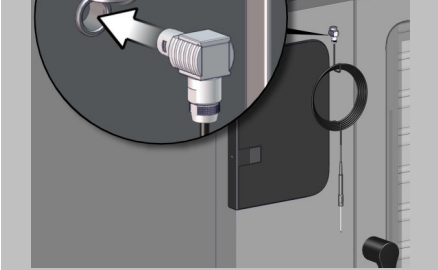
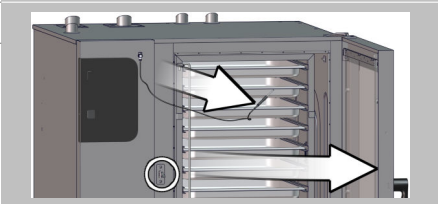
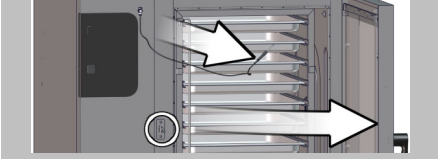
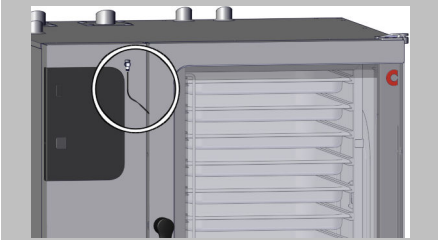
- | | | |
|----|---|--|
| 1. |  | Open the protective cap on the connector for the external core temperature probe or sous vide probe. The connector is located on the right above the operating panel on the unit case. |
| 2. |  | Plug the external core temperature probe or sous vide probe into the unit using the connector. |
| 3. |  | Open the unit door. |
| 4. |  | Insert the core temperature probe or sous vide probe into the food. |
| 5. |  | Close the unit door.
Pay attention to the cable when doing so. When being routed into the oven, the cable must not go through the door handle locking mechanism's area. Instead, it can be routed through any other point so that it will be held in place between the unit door and the hygienic plug-in gasket. |

Remove and store the external core temperature probe or sous-vide probe

1.

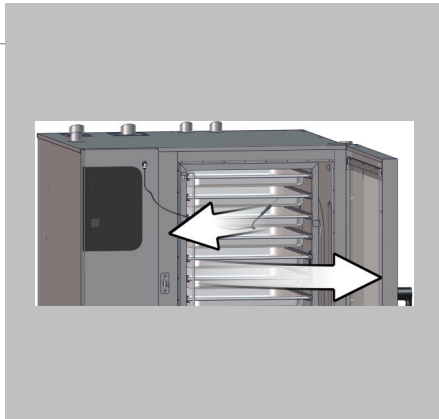

Open the unit door.

2.

⚠ WARNING

Risk of burns due to high temperatures inside the oven cavity. This includes all parts that are or have been inside the oven cavity during cooking

- Wear the required personal protective equipment.
- Once you are done using the external core temperature probe or sous vide probe, let it cool down outside the oven before unplugging and cleaning it.

Remove the core temperature probe or sous vide probe from the food before removing the food from the oven cavity.

3.

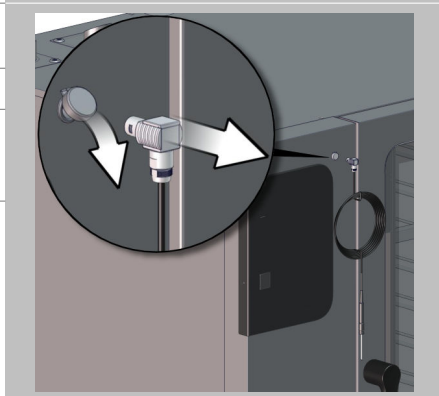

Unplug the external core temperature probe or sous-vide probe from the unit case.

4.

Close the connector's protective cap.

5.

Clean and rinse the core temperature probe or sous vide probe with a soft cloth, common household dishwashing liquid, and water.

6.

Store the dried core temperature probe or sous vide probe in a suitable place in order to protect it from being damaged or soiled.

4.3.6 Using a USB Stick

⚠ For your safety when working with/on the combi oven

Before starting work, read and understand the rules, risks, and hazards specified in the 'For Your Safety on page 17' section and in these instructions and follow all the corresponding instructions without exception.

Purpose of USB sliding cover

The sliding cover protects the USB port so that no steam will be able to enter the control system electronics during cooking or cleaning.

Make sure that there is no USB stick plugged in and that the port is sealed off by the slider during cooking and cleaning.

Plugging in the USB stick for easyTouch

1.  Open the USB port cover on the operating panel.

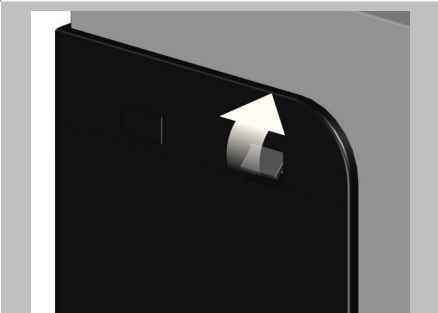
2.  Push the USB port cover on the operating panel upward.

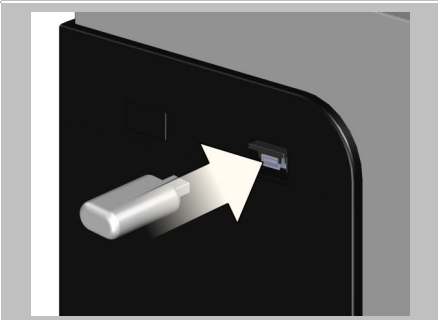
3.  Plug in the USB stick.
If the USB stick is too big, use an adapter cable.

Plugging in the USB stick for easyDial

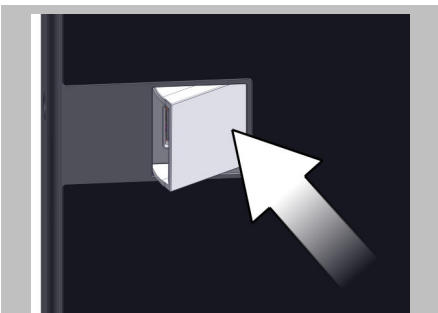
1.  Open the USB port cover on the operating panel.

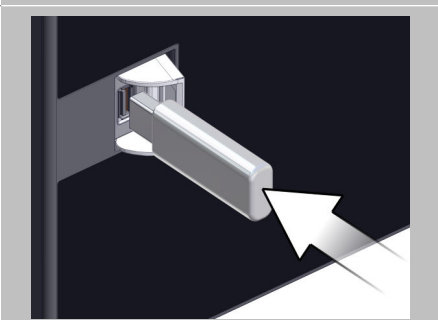
2.  Plug in the USB stick.
If the USB stick is too big, use an adapter cable.

4.3.7 Removing and Installing the Racks

⚠ For your safety when working with/on the combi oven

Before starting work, read and understand the rules, risks, and hazards specified in the 'For Your Safety on page 17' section and in these instructions and follow all the corresponding instructions without exception.

Procedures that you must be familiar with

You will need to be familiar with the following steps:

- Safely Opening and Closing the Unit Door 42
- Putting Away and Removing the Core Temperature Probe 46

Prerequisites

- All food containers and other accessories used for cooking must have been removed from the oven cavity.

Removing the racks (standard model)

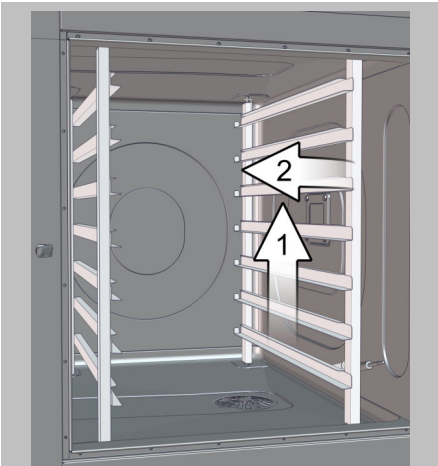
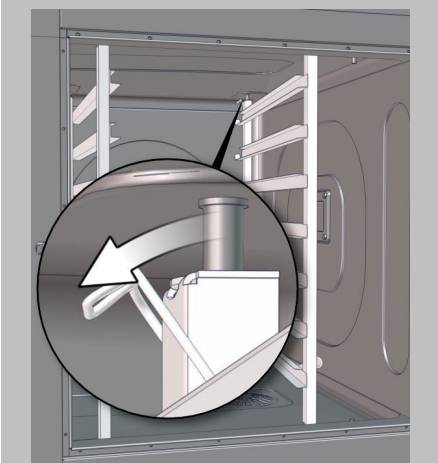
1.  Lift (1) the rack and swing it (2) towards the inside of the oven cavity.
2.  Release the retainer on the rear top corner that is holding the rack in place.

3.

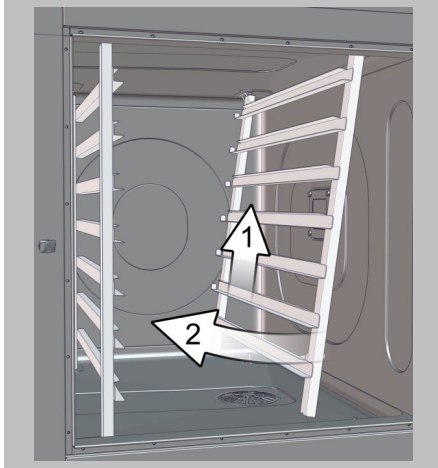

Push (1) the rack upwards and remove (2) it.

Installing the racks (standard model)

1.

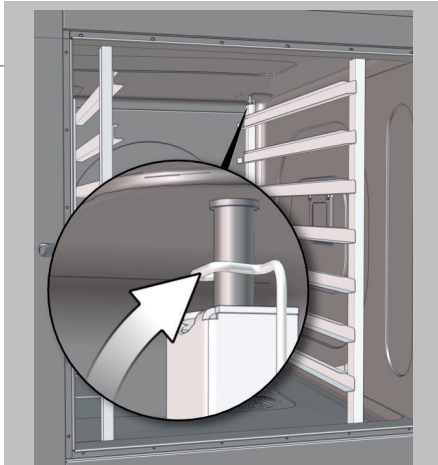

Follow the same steps used to remove the racks, but in opposite order.

2.

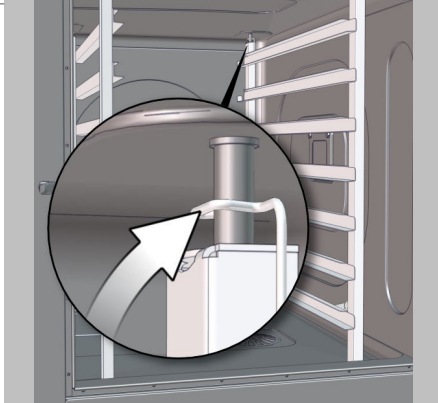

Check to make sure that the retainers on the rear top corners are engaging the racks properly so that the latter are correctly secured.

3.

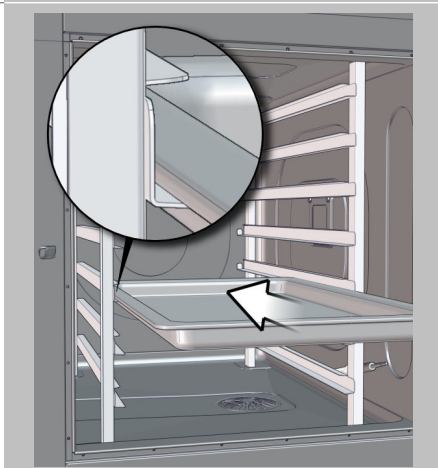

- To check that both racks are properly installed, slide a bakeware item in.
- Check to make sure that the bakeware is correctly in place in or on the rails as indicated in 'Placing Bakeware Inside the Unit.' on page 31

Removing the racks (bakery model)

1.

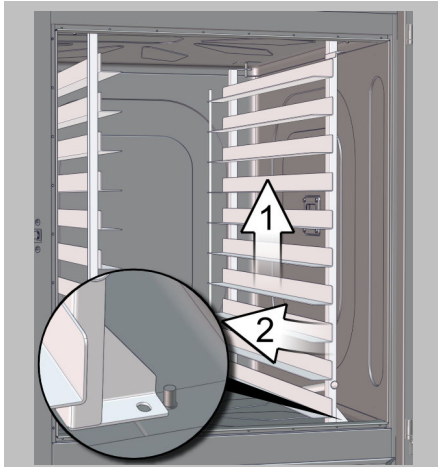

Lift (1) the rack and swing it (2) towards the inside of the oven cavity a little bit in order to remove it from the pin in the oven's front lower area.

2.

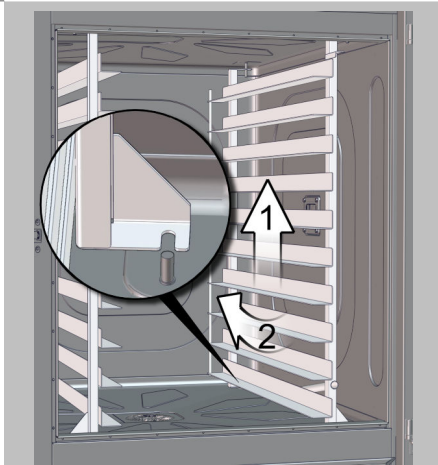

Slightly lift (1) the rack again and swing it (2) a little bit to the side in order to remove it from the pin in the oven cavity's lower rear area.

3.

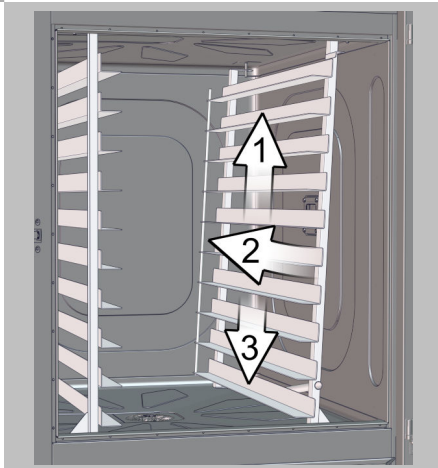

Remove the rack from the two upper pins inside the oven cavity by slightly lifting the rack again (1), swinging it towards the inside of the oven a little bit (2), and then letting it down (3).

Installing the racks (bakery model)

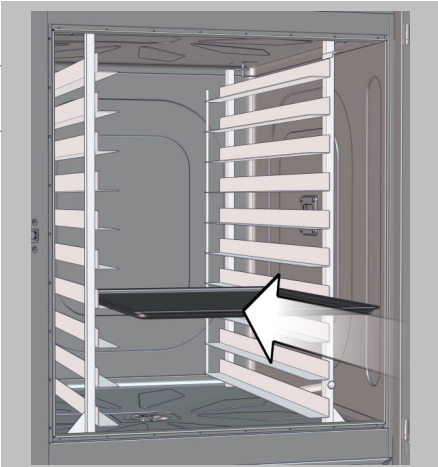
- | | | |
|----|---|--|
| 1. |  | Follow the same steps used to remove the racks, but in opposite order. |
| 2. | | Check to make sure that all eight pins (four on each side) are properly engaging the racks' guides. |
| 3. | | <ul style="list-style-type: none">▪ To check that both racks are properly installed, slide a sheet pan in.▪ Check to make sure that the baking tray is correctly in place on the rails as indicated in 'Placing Bakeware Inside the Unit' on page 31. |

4.3.8 Filling the Smoker Box, Placing It Inside the Unit, and Removing It from the Unit (ConvoSmoke Only)

⚠ For your safety when working with/on the combi oven

Before starting work, read and understand the rules, risks, and hazards specified in the 'For Your Safety on page 17' section and in these instructions and follow all the corresponding instructions without exception.

Procedures that you must be familiar with

You will need to be familiar with the following steps:

- Safely Opening and Closing the Unit Door

42

Smoking bisquettes

Only use smoking bisquettes that are made of hardwood chips and are intended for this purpose. The manufacturer recommends using BRADLEY SMOKING BISQUETTES, which can be bought on the Internet (<http://www.bradleysmoker.com>) or at appropriate specialty retailers. Do NOT use smoking materials such as loose sawdust, loose wood shavings, loose wood chips, or small pieces of wood.

Prerequisites

- The oven cavity must have cooled down to the ambient temperature since the last time it was used.
or:
The software must have prompted you to put the smoker box inside as part of the cooking profile that is running. In this case, the software will automatically run a 'Cool down' sequence to cool down the oven cavity before prompting you to put the smoker box inside.
- The smoker heater must be in place inside the oven cavity.
- The racks have been installed and are locked in place.
- The smoker box's bisquette support lid, cover, and actual box must have been properly cleaned and dried.

Filling the smoker box

1.

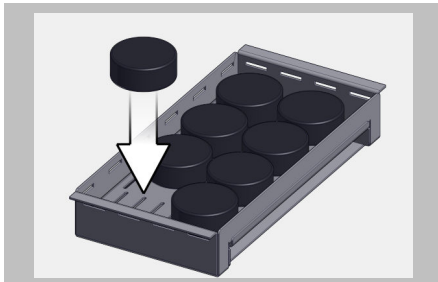

To fill the smoker box, place a maximum of eight bisquettes on the bisquette support lid inside it.

2.

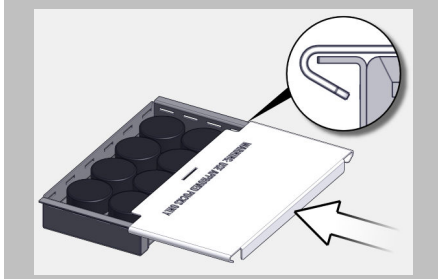

Starting from the back of the box, slide the cover onto the smoker box as far as it will go. Make sure that the folds on the sides of the cover slide along the wings on the sides of the box (as shown in the diagram to the left).

3.

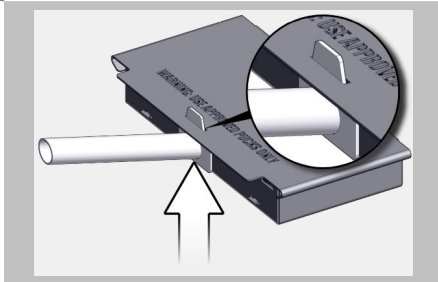

Insert the handle into the front of the smoker box.

Placing the smoker box inside the oven cavity

1.

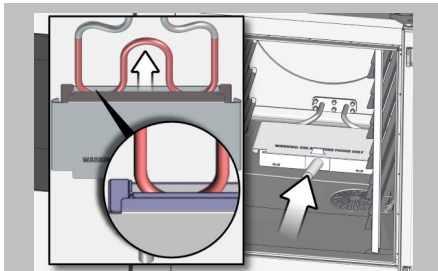

Grab the smoker box containing the bisquettes from the handle and slide it all the way onto the smoker heater inside the oven cavity. Make sure that the heating element goes into the smoker box opening meant for the smoker heater.

2.

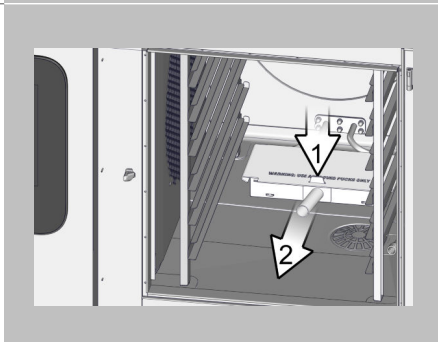

⚠ WARNING

Risk of burns posed by high temperatures inside the oven cavity, on the inside of the unit door, and on the smoker box

- Wear the required personal protective equipment.
- Once you have placed the smoker box inside the oven cavity, take the box's handle out of the compartment so that the handle will be cold when you take out the box later on.

Remove the smoker box's handle.

Removing the smoker box from the oven cavity

1.

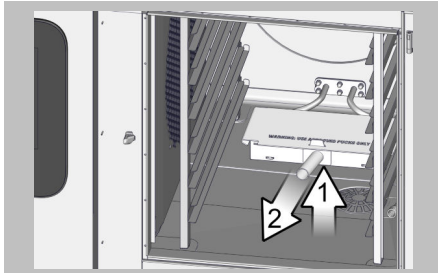

Insert the handle into the smoker box and pull the box out from the smoker heater.

2.



⚠ WARNING

Risk of burns and fire hazard posed by flying sparks

- Do not remove the smoker box's cover until the box has cooled down completely in a fireproof location that is not exposed to wind. Always keep the cover on the smoker box during smoking.
- Do not dispose of ashes or used bisquettes until they are cold.

Let the smoker box fully cool down outside of the oven cavity in a fireproof location that is not exposed to wind.

3.



Empty the smoker box of ashes and the remains of the bisquettes you used and thoroughly clean all of the smoker box's parts.

5 How to Clean the Combi Oven

5.1 Combi Oven Cleaning Basics

5.1.1 Cleaning Methods

Cleaning Methods

Cleaning Methods	Description	When to use
Oven cleaning without cleaning agents	<ul style="list-style-type: none"> Is a fully automatic process in which the temperature and duration are controlled by the software The oven cavity is rinsed with water only (without using any cleaning agents) 	<ul style="list-style-type: none"> For cleaning very light soiling or eliminating odors between individual cooking sequences After prolonged periods of nonuse (to remove dust, for example), provided the combi oven has been thoroughly cleaned before this
Fully automatic oven cleaning with connected canisters (ConvoClean for easyDial or ConvoClean+ for easyTouch)	<ul style="list-style-type: none"> Is a fully automatic process in which the temperature, duration, use of cleaning agents, and rinsing are controlled by the software The cleaning agents will be dosed by the software and automatically conveyed to the oven cavity from connected canisters or the software will prompt the operator to apply cleaning agent from single-measure dispensing bottles into the oven cavity 	<ul style="list-style-type: none"> Daily cleaning after finishing all cooking for the day Before placing the combi oven into operation for the first time in order to get rid of all oven cavity soiling and impurities accumulated during transit, setup, and installation After performing maintenance on the combi oven in order to get rid of all oven cavity soiling and impurities
Semi-automatic oven cleaning	<ul style="list-style-type: none"> Is a semi-automatic process in which the temperature and duration of individual cleaning phase are controlled by the software The cleaning agents are manually sprayed into the oven cavity The oven cavity is rinsed out manually using the recoil hand shower or, alternatively, is wiped thoroughly with plenty of clean water and a soft cloth 	<ul style="list-style-type: none"> Daily cleaning after finishing all cooking for the day For further cleaning after fully automatic oven cleaning if the latter did not get rid of all soiling and impurities Before placing the combi oven into operation for the first time in order to get rid of all oven cavity soiling and impurities accumulated during transit, setup, and installation After performing maintenance on the combi oven in order to get rid of all oven cavity soiling and impurities

Cleaning Methods	Description	When to use
Oven cleaning using only rinse aid from a connected canister or single-measure dispensing	<ul style="list-style-type: none"> ▪ With easyTouch only: Cleaning profile ConvoCare ▪ Is a fully automatic process in which the temperature, duration, use of rinse aid, and rinsing are controlled by the software ▪ Rinse aid will either be automatically added to the oven cavity from connected canisters in the right proportion or the software will prompt the operator to apply rinse aid from single-measure dispensing bottles into the oven cavity 	<ul style="list-style-type: none"> ▪ For further cleaning after fully automatic or semi-automatic oven cleaning if the latter did not get rid of all soiling and impurities ▪ If there is a white film or dark discolorations inside the oven cavity
Manual oven cleaning	<ul style="list-style-type: none"> ▪ Is an exclusively manual process without any software assistance <ul style="list-style-type: none"> ▪ The oven cavity remains unheated ▪ The operator monitors the time during which the cleaning agents are allowed to work. ▪ The cleaning agents are manually sprayed into the oven cavity ▪ The oven cavity is rinsed out manually using the recoil hand shower or, alternatively, is wiped thoroughly with plenty of clean water and a soft cloth 	<ul style="list-style-type: none"> ▪ For cleaning soiling or eliminating odors between individual cooking sequences after the oven cavity has been cooled down ▪ For further cleaning after fully automatic or semi-automatic oven cleaning if the latter did not get rid of all soiling and impurities ▪ For cleaning specific spots or areas inside the oven cavity, such as the oven drain ▪ If there is a white film or dark discolorations inside the oven cavity

Visual inspection to ensure that there are no residues left after cleaning

Every time after cleaning with one of the aforementioned cleaning methods, carry out a visual inspection to make sure that there are no residues left.

5.1.2 Cleaning Agent Delivery for Fully Automatic Cleaning Processes

Cleaning agent delivery versions

The type of cleaning agent delivery for the combi oven's fully automatic cleaning processes is determined by a setting in the software. This software setting defines whether it is possible or NOT possible to deliver cleaning agents from single-measure dispensing bottles. A qualified service technician from an authorized service company can change this setting at any time.

The following applies to cleaning agent delivery for fully automatic cleaning processes depending on the setting:

	Single-measure dispensing bottle software setting ON	Single-measure dispensing bottle software setting OFF
Fully automatic cleaning processes in general	<ul style="list-style-type: none"> ▪ Cleaning agent will be delivered exclusively with single-measure dispensing bottles. ▪ Even if there are connected canisters, NO cleaning agent or rinse aid will be drawn from the canisters. 	<ul style="list-style-type: none"> ▪ Canisters with cleaning agent and rinse aid must be connected to the combi oven. <p>With easyDial only:</p> <ul style="list-style-type: none"> ▪ Delivering cleaning agent or rinse aid from single-measure dispensing bottles instead will NOT be possible.
Fully automatic oven cleaning (ConvoClean for easyDial or ConvoClean+ for easyTouch)	At specific times in the cleaning process, the operator will be prompted by the software to bring one or more single-measure dispensing bottles with cleaning agent or rinse aid into the oven cavity.	<ul style="list-style-type: none"> ▪ Cleaning agent and rinse aid will be dosed by the software and conveyed from the connected canisters into the oven cavity fully automatically. <p>With easyTouch only:</p> <ul style="list-style-type: none"> ▪ Delivering cleaning agent or rinse aid from single-measure dispensing bottles instead will NOT be possible.
Oven cleaning with ConvoCare rinse aid only	<ul style="list-style-type: none"> ▪ With easyTouch only: Cleaning profile ConvoCare ▪ The software offers this cleaning profile only for the single-measure dispensing bottle option. The operator will be prompted by the software to bring single-measure dispensing bottles with rinse aid into the oven cavity. 	<ul style="list-style-type: none"> ▪ The software offers this cleaning profile both for the canister option and for the single-measure dispensing bottle option. ▪ In the case of the canister option, the rinse aid will be dosed by the software and conveyed from the connected canister into the oven cavity fully automatically. ▪ In the case of the single-measure dispensing bottle option, the operator will be prompted by the software to bring single-measure dispensing bottles with rinse aid into the oven cavity.
Oven cleaning without cleaning agents	This cleaning profile is not affected by the software setting.	This cleaning profile is not affected by the software setting.

5.1.3 Cleaning schedule

Overview

The figure below shows a size 6.10 electric combi oven used as an example representing all table-top models:

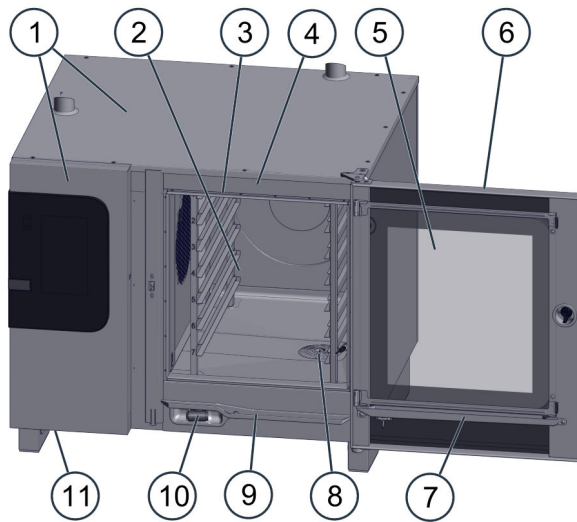

No.	Designation
1	Outside of unit case
2	Oven cavity
3	Camera, only with the ConvoSense assistance system (not shown)
4	hygienic plug-in gasket
5	Triple glazing door
6	Unit door
7	Door drip tray
8	Oven drain with strainer
9	Unit drip tray
10	Recoil hand shower
11	Fan grill

Daily cleaning

More frequent cleaning may be required depending on the degree of soiling.

What needs to be cleaned?	Procedure	Cleaning agents
Oven cavity	'How to Semi-Automatically Clean the Oven Cavity' on page 70	ConvoClean forte
	'How to Fully Automatically Clean the Oven Cavity Using Canisters' on page 63	ConvoClean forte and ConvoCare
	'How to Fully Automatically Clean the Oven Cavity Using the Single-Measure Dispensing Mode' on page 64	ConvoClean forte S and ConvoCare S
Recoil hand shower	Rinse thoroughly with water at least once	-
Oven drain	<ul style="list-style-type: none"> ▪ Remove any residues ▪ Rinse out in order to prevent clogging ▪ Spray cleaning agent inside and rinse with water 	<ul style="list-style-type: none"> ▪ With a water jet ▪ ConvoClean forte
Hygienic plug-in gasket around unit door	<ul style="list-style-type: none"> ▪ Wipe all around by hand using a soft cloth and cleaning agent ▪ Thoroughly wipe clean with a soft cloth and water ▪ Dry with a soft cloth ▪ Leave the unit door ajar so that the hygienic plug-in gasket will dry off 	Common household dishwashing liquid

What needs to be cleaned?	Procedure	Cleaning agents
Outside of unit case, incl. control panel	Clean by hand with a soft cloth Follow the rules below: <ul style="list-style-type: none"> ▪ Do not clean the unit's outer case with a water jet. ▪ De-energize the unit when cleaning the outside. 	Common household dishwashing liquid / glass cleaner
Outside of camera (with ConvoSense only)	Clean by hand with a soft cloth	Common household dishwashing liquid
Bakeware, sheet pans, shelf grills, and other accessories used for cooking	<ul style="list-style-type: none"> ▪ Clean by hand using a soft, non-abrasive sponge ▪ Rinse with water 	Common household dishwashing liquid
Smoker box (with ConvoSmoke only)	<ul style="list-style-type: none"> ▪ Clean manually with a brush with soft bristles ▪ Rinse with water 	Common household dishwashing liquid
The oven cavity needs to be checked daily to see if there is any white film or dark discolorations <ul style="list-style-type: none"> ▪ Clean only if necessary 	<ul style="list-style-type: none"> ▪ Manually: <ul style="list-style-type: none"> ▪ Spray cleaning agent on the film/discolorations while the combi oven is not warm ▪ Let the cleaning agent work for 10 minutes ▪ Polish using a soft, non-abrasive sponge ▪ Rinse out <p>or</p> <ul style="list-style-type: none"> ▪ 'How to Clean the Oven Cavity Using Rinse Aid Only and the ConvoCare Cleaning Profile (easyTouch Only)' on page 68 	ConvoCare
Grease collection canister (with ConvoGrill only)	'Emptying and Cleaning the Grease Collection Canister' on page 81	Common household dishwashing liquid

Weekly cleaning

What needs to be cleaned?	Procedure	Cleaning agents
Inside of triple glazing door and LED strip	'How to Clean the Triple Glazing Door's Inner Panes and LED Strip' on page 73	Common household dishwashing liquid / glass cleaner
The oven cavity section behind the suction panel	'How to Clean the Oven Cavity Section Behind the Suction Panel' on page 72	ConvoClean forte
Unit door, door drip tray, and unit drip tray	<ul style="list-style-type: none"> ▪ Clean by hand using a soft cloth and cleaning agent ▪ Thoroughly wipe clean with a soft cloth and water ▪ Dry with a soft cloth 	Common household dishwashing liquid
Fan grill, oven bottom on the left side	Clean by hand with a slightly damp cloth	Common household dishwashing liquid
Stand (optional)	Clean by hand with a soft cloth	Common household stainless steel cleaner

Monthly cleaning

What needs to be cleaned?	Procedure	Cleaning agents
The hygienic plug-in gasket, thoroughly	'How to Clean the Hygienic Plug-In Gasket Thoroughly' on page 74	Common household dishwashing liquid

Additional required cleaning

The following cleaning is required in addition to regular cleaning:

- The unit must be cleaned before the first time it is operated.
- The unit must be cleaned before and after downtimes.
- The unit must be cleaned after maintenance work.

5.1.4 Cleaning agents

Cleaning agents

Only use the cleaning agents specified here when cleaning the combi oven and its accessories.

Product	Use for	Container
ConvoClean forte For normal to heavy soiling ▪ Not for cleaning bakeware, sheet pans, shelf grills, or other accessories	Oven cleaning ▪ By hand ▪ Semi-automatic Fully automatic oven cleaning	Spray bottle Cleaning agent canisters connected to the cleaning system underneath the combi oven
ConvoCare Concentrate	For preparing ready-to-use ConvoCare solution with a defined mix ratio	-
ConvoCare (Ready to use) Rinse aid with defined mix ratio ▪ Not for cleaning bakeware, sheet pans, shelf grills, or other accessories	▪ Fully automatic oven cleaning ▪ Oven cleaning with rinse aid only, ConvoCare cleaning profile Manually cleaning the oven cavity further	Cleaning agent canisters connected to the cleaning system underneath the combi oven Spray bottle
ConvoClean forte S For normal to heavy soiling	Fully automatic oven cleaning	0.26-pint single-measure dispensing bottles
ConvoCare S	▪ Fully automatic oven cleaning ▪ Oven cleaning with rinse aid only, ConvoCare cleaning profile	0.26-pint single-measure dispensing bottles
Common household glass cleaner	▪ Cleaning the control panel ▪ Cleaning the triple glazing door	-
Common household alkali-free, pH-neutral, odorless dishwashing liquid	▪ Cleaning the outside of the unit case, incl. the control panel ▪ Cleaning components and accessories as specified in the corresponding instructions ▪ Cleaning bakeware, sheet pans, shelf grills, and other accessories used for cooking	-
Common household stainless steel cleaner	▪ Cleaning the equipment stand (optional)	-

Handling cleaning agents

Personal protective equipment needs to be worn when handling some of the cleaning agents above. Always observe the 'Personal Protective Equipment' on page 29 section and the labels for the cleaning agents.

Staff must be briefed by the person responsible for the combi oven on a regular basis.

5.1.5 Supplying Cleaning Agents

Supplying Cleaning Agents

Container	Handling / Use	Cleaning agents
Spray bottle	<ul style="list-style-type: none"> ▪ Never leave the spray bottle pressurized for an extended period of time if you are not using it. Slowly open the pump head so that the compressed air can escape. ▪ Rinse the spray bottle weekly. ▪ Rinse the nozzle, the nozzle extension, and the nozzle fitting after every use. ▪ Do not store spray bottles containing cleaning agents in the immediate vicinity of the combi oven. Instead, store them in special storage rooms where they will not be close to nor come into contact with food. 	<ul style="list-style-type: none"> ▪ ConvoClean forte ▪ ConvoCare
Canister	<ul style="list-style-type: none"> ▪ Connect the canisters containing the cleaning agents to the combi oven's cleaning system. ▪ Before every fully automatic oven cleaning sequence, check whether the canisters still have enough cleaning agent in them. ▪ Do not store reserve canisters containing cleaning agents in the immediate vicinity of the combi oven. Instead, store them in special storage rooms where they will not be close to nor come into contact with food. 	<ul style="list-style-type: none"> ▪ ConvoClean forte ▪ ConvoCare (Ready to use)
	<ul style="list-style-type: none"> ▪ Use ConvoCare Concentrate only to prepare ready-to-use ConvoCare solution (with the defined mix ratio) in an empty canister. ▪ Do not store canisters containing ConvoCare Concentrate in the immediate vicinity of the combi oven. Instead, store them in special storage rooms where they will not be close to nor come into contact with food. 	<ul style="list-style-type: none"> ▪ ConvoCare Concentrate
0.26-pint single-measure dispensing bottles	<ul style="list-style-type: none"> ▪ Do not remove the bottle from the shipping and storage box until right before using the cleaning agent. ▪ Do not open the bottle's cap until right before using the cleaning agent. ▪ Once the bottles are empty, rinse them out with water and close them again, then throw them into the recycling bin. ▪ Store the reserve bottles containing cleaning agents exclusively in the box in which they were shipped. Do not store the boxes in the immediate vicinity of the combi oven. Instead, store them in special storage rooms where they will not be close to nor come into contact with food. 	<ul style="list-style-type: none"> ▪ ConvoClean forte S ▪ ConvoCare S

5.2 Fully automatic cleaning process instructions

5.2.1 How to Fully Automatically Clean the Oven Cavity Using Canisters

▲ For your safety when working with/on the combi oven

Before starting work, read and understand the rules, risks, and hazards specified in the 'For Your Safety on page 17' section and in these instructions and follow all the corresponding instructions without exception.

Procedures that you must be familiar with

You will need to be familiar with the following steps:

- Safely Opening and Closing the Unit Door 42
- Replacing the rinse aid and cleaning agent canisters 82



Working with the canisters



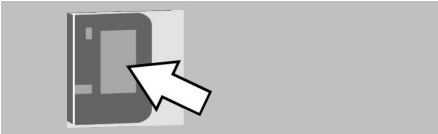

- Make sure that the canisters are in the intended position

Prerequisites

- You must be familiar with how to use the software to such an extent that you will be able to access and start the various cleaning profiles, please refer to the combi oven's operating instructions.
- The unit and the accessories being used do not have any obvious damage.
- The supply lines installed for electrical power, water, and wastewater do not have any obvious damage, have a secure fit, are not dripping anywhere, and appear to be safe and fully functional after a visual inspection.
- All food must have been taken out from the oven cavity. There must not be any foreign objects inside the oven cavity.
- All bakeware, sheet pans, and shelf grills, as well as any other accessories, must have been taken out from the oven cavity.
- The oven cavity drain must be clear. It must not be clogged or blocked by any residues. The strainer on the oven drain must be in place.
- The unit door's inner panes are properly locked in place.
- The suction panel is properly locked in place.
- The unit door must be closed.
- You must supply the fluids required by the cleaning program you will be using. Please refer to 'Supplying Cleaning Agents' on page 62.

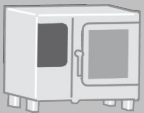
How to Fully Automatically Clean the Oven Cavity Using Canisters

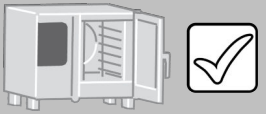
1.  Open the cleaning profile and start the cleaning sequence.
2.  Follow the software's prompts.
 - If the oven cavity is being pre-heated, wait for the pre-heating to end and then continue to step 4.
 - If the oven cavity is being cooled down, continue to step 3.

<p>3.</p>		<p>⚠ CAUTION</p> <p>Risk of scalding posed by hot steam</p> <ul style="list-style-type: none"> ▪ Be ready for a bigger rush of steam than usual. ▪ Have everyone around step back from the unit. ▪ Slowly and carefully open the unit door. <p>Open the unit door and wait until the oven has cooled down.</p>
<p>4.</p>		<p>Close the unit door. Result: Cleaning sequence in progress.</p>
<p>5.</p>		<p>⚠ CAUTION</p> <p>Skin and eye irritation hazard and chemical burn hazard</p> <ul style="list-style-type: none"> ▪ During the cleaning sequence, open the unit door only after being prompted to do so by the software. <p>Wait until the cleaning sequence is done.</p>
<p>6.</p>		<p>Once the cleaning sequence is done, the unit will make a sound to let you know. Follow the software's prompts.</p>
<p>7.</p>		<ul style="list-style-type: none"> ▪ Open the unit door and check to make sure that everything has been cleaned properly. The oven cavity should be visibly clean and should not give off any smells typical of food leftovers or cleaning agents. ▪ Check the oven cavity to make sure that no foreign objects got in during rinsing. If there are any foreign objects, remove them. ▪ If additional cleaning is required, clean and rinse the oven cavity manually or by running a cleaning profile once again.
<p>8.</p>		<p>Leave the unit door ajar in order to let the oven cavity dry out.</p>

5.2.2 How to Fully Automatically Clean the Oven Cavity Using the Single-dose Dispensing Bottle

⚠ For your safety when working with/on the combi oven

Before starting work, read and understand the rules, risks, and hazards specified in the 'For Your Safety on page 17' section and in these instructions and follow all the corresponding instructions without exception.

Procedures that you must be familiar with

You will need to be familiar with the following steps:

- Safely Opening and Closing the Unit Door 42
- Adding Cleaning Agent from Single-Measure Dispensing Bottles to the Inside of the Oven Cavity 84





Handling single-dose dispensing bottles











- Make sure that the work surface does not come into contact with cleaning agent or rinse aid.
- Do not put empty single-measure dispensing bottles down on the work surface, as drops of cleaning agent or rinse aid may run down along the outside of the bottles.
- Wear the required personal protective equipment

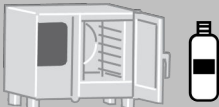

Prerequisites

- You must be familiar with how to use the software to such an extent that you will be able to access and start the various cleaning profiles, please refer to the combi oven's operating instructions.
- The unit and the accessories being used do not have any obvious damage.
- The supply lines installed for electrical power, water, and wastewater do not have any obvious damage, have a secure fit, are not dripping anywhere, and appear to be safe and fully functional after a visual inspection.
- All food must have been taken out from the oven cavity. There must not be any foreign objects inside the oven cavity.
- All bakeware, sheet pans, and shelf grills, as well as any other accessories, must have been taken out from the oven cavity.
- The oven cavity drain must be clear. It must not be clogged or blocked by any residues. The strainer on the oven drain must be in place.
- The unit door's inner panes are properly locked in place.
- The suction panel is properly locked in place.
- The unit door must be closed.
- You must supply the fluids required by the cleaning program you will be using. Please refer to 'Supplying Cleaning Agents' on page 62.

How to Fully Automatically Clean the Oven Cavity Using the Single-Measure Dispensing Mode

1.		Open the cleaning profile and start the cleaning sequence.
2.		<p>With easyDial only: Continue with step 5.</p> <p>With easyTouch only: Follow the software's prompts.</p> <ul style="list-style-type: none"> ▪ If the oven cavity is being pre-heated, wait for the pre-heating to end and then continue to step 4. ▪ If the oven cavity is being cooled down, continue to step 3.
3.		<p>⚠ CAUTION</p> <p>Risk of scalding posed by hot steam</p> <ul style="list-style-type: none"> ▪ Be ready for a bigger rush of steam than usual. ▪ Have everyone around step back from the unit. ▪ Slowly and carefully open the unit door. <p>Open the unit door and wait until the oven has cooled down.</p>
4.		Close the unit door. Result: Cleaning sequence in progress.
5.		Wait for the soaking phase to be done (approx. 5 – 10 minutes depending on the selected cleaning profile).

6.		<ul style="list-style-type: none"> Once the soaking phase is done, the unit will make an acoustic signal to let you know. You will be prompted to add cleaning agent to the inside. The software will indicate how many single-measure dispensing bottles are needed.
7.		<p>Open the unit door.</p>
8.		<p>⚠ WARNING</p> <p>Risk of chemical burns and skin, eye, and respiratory tract irritation</p> <ul style="list-style-type: none"> Do not let the cleaning agents or rinse aid from single-dose dispensing bottles come into contact with your eyes, skin, or mucous membranes. Do not open the unit door during the fully automatic oven cleaning process UNTIL prompted to do so by the software. Wear the required personal protective equipment. <p>Add cleaning agent from the single-measure dispensing bottles to the inside of the oven cavity.</p>
9.		<p>Close the unit door.</p>
10.		<p>Wait for the cleaning phase to be done (approx. 30 – 60 minutes depending on the selected cleaning profile).</p>
		<p>With easyTouch only: If you select the 'Express' cleaning duration in the cleaning profile, skip steps 11 through 15.</p>
11.		<ul style="list-style-type: none"> Once the cleaning phase is done, the unit will make an acoustic signal to let you know. You will be prompted to add rinse aid to the inside. The software will indicate how many single-measure dispensing bottles are needed. <p>In exceptional cases, you can skip adding rinse aid depending on the water hardness and the degree of scale build-up in the unit.</p>
12.		<p>Open the unit door.</p>
13.		<p>Add rinse aid from the single-measure dispensing bottles to the inside of the oven cavity.</p>
14.		<p>Close the unit door.</p>
15.		<p>Wait for the last cleaning phase to be done (approx. 20 – 30 minutes depending on the selected cleaning profile).</p>

16.		<ul style="list-style-type: none"> Once the last cleaning phase is done, the unit will make an acoustic signal to let you know. Follow the software's prompts.
17.		<ul style="list-style-type: none"> Open the unit door and check to make sure that everything has been cleaned properly. The oven cavity should be visibly clean and should not give off any smells typical of food leftovers or cleaning agents. Check the oven cavity to make sure that no foreign objects got in during rinsing. If there are any foreign objects, remove them. If additional cleaning is required, clean and rinse the oven cavity manually or by running a cleaning profile once again.
18.		<p>Leave the unit door ajar in order to let the oven cavity dry out.</p>

5.2.3 How to Clean the Oven Cavity Without Using Cleaning Agents

⚠ For your safety when working with/on the combi oven

Before starting work, read and understand the rules, risks, and hazards specified in the 'For Your Safety on page 17' section and in these instructions and follow all the corresponding instructions without exception.

Procedures that you must be familiar with

You will need to be familiar with the following steps:



- Safely Opening and Closing the Unit Door



42

Prerequisites

- You must be familiar with how to use the software to such an extent that you will be able to access and start the various cleaning profiles, please refer to the combi oven's operating instructions.
- All food must have been taken out from the oven cavity. There must not be any foreign objects inside the oven cavity.
- The oven drain must be clear. It must not be clogged or blocked by any residues. The strainer on the oven drain must be in place.
- The unit door's inner panes are properly locked in place.
- The suction panel is properly locked in place.
- The unit door must be closed.

How to Clean the Oven Cavity Without Using Cleaning Agents

1.		<p>Open the cleaning profile and start the cleaning sequence.</p>
2.		<p>Wait until the cleaning sequence is done.</p>

3.		<p>Once the cleaning sequence is done, the unit will make a sound to let you know. Follow the software's prompts.</p>
4.		<ul style="list-style-type: none"> ▪ Open the unit door and check to make sure that everything has been cleaned properly. ▪ Check the oven cavity to make sure that no foreign objects got in during rinsing. If there are any foreign objects, remove them. ▪ If necessary, clean and rinse the oven cavity manually or by running a different cleaning profile.
5.		<p>Leave the unit door ajar in order to let the oven cavity dry out.</p>

5.2.4 How to clean the oven cavity using only rinse aid from connected canisters (easyTouch only)

▲ For your safety when working with/on the combi oven

Before starting work, read and understand the rules, risks, and hazards specified in the 'For Your Safety on page 17' section and in these instructions and follow all the corresponding instructions without exception.

Procedures that you must be familiar with

You will need to be familiar with the following steps:

- Safely Opening and Closing the Unit Door 42
- Replacing the rinse aid and cleaning agent canisters 82

Prerequisites

- You must be familiar with how to use the software to such an extent that you will be able to access and start the various cleaning profiles, please refer to the combi oven's operating instructions.
- The unit and the accessories being used do not have any obvious damage.
- The supply lines installed for electrical power, water, and wastewater do not have any obvious damage, have a secure fit, are not dripping anywhere, and appear to be safe and fully functional after a visual inspection.
- All food must have been taken out from the oven cavity. There must not be any foreign objects inside the oven cavity.
- All bakeware, sheet pans, and shelf grills, as well as any other accessories, must have been taken out from the oven cavity.
- The oven cavity drain must be clear. It must not be clogged or blocked by any residues. The strainer on the oven drain must be in place.
- The unit door's inner panes are properly locked in place.
- The suction panel is properly locked in place.
- The unit door must be closed.
- You must supply the fluids required by the cleaning program you will be using. Please refer to 'Supplying Cleaning Agents' on page 62.

How to clean the oven cavity only using rinse aid from connected canisters

The cleaning process for the ConvoCare cleaning profile using connected canisters is exactly the same as that outlined in 'How to Fully Automatically Clean the Oven Cavity Using Canisters' on page 63.

5.2.5 How to clean the oven cavity using only rinse aid from single-dose dispensing bottles (easyTouch only)

▲ For your safety when working with/on the combi oven

Before starting work, read and understand the rules, risks, and hazards specified in the 'For Your Safety on page 17' section and in these instructions and follow all the corresponding instructions without exception.

Procedures that you must be familiar with



You will need to be familiar with the following steps:





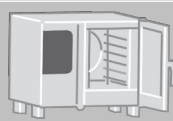

- Safely Opening and Closing the Unit Door 42
- Adding Cleaning Agent from Single-Measure Dispensing Bottles to the Inside of the Oven Cavity 84

Prerequisites

- You must be familiar with how to use the software to such an extent that you will be able to access and start the various cleaning profiles, please refer to the combi oven's operating instructions.
- The unit and the accessories being used do not have any obvious damage.
- The supply lines installed for electrical power, water, and wastewater do not have any obvious damage, have a secure fit, are not dripping anywhere, and appear to be safe and fully functional after a visual inspection.
- All food must have been taken out from the oven cavity. There must not be any foreign objects inside the oven cavity.
- All bakeware, sheet pans, and shelf grills, as well as any other accessories, must have been taken out from the oven cavity.
- The oven cavity drain must be clear. It must not be clogged or blocked by any residues. The strainer on the oven drain must be in place.
- The unit door's inner panes are properly locked in place.
- The suction panel is properly locked in place.
- The unit door must be closed.
- You must supply the fluids required by the cleaning program you will be using. Please refer to 'Supplying Cleaning Agents' on page 62.

How to Clean the Oven Cavity Using Rinse Aid Only

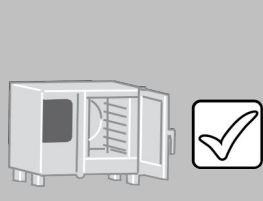
1.		Open the ConvoCare S cleaning profile that uses single-dose dispensing and start the cleaning sequence.
2.		Wait for the first cleaning phase to be done (approx. 10 minutes).
3.		<ul style="list-style-type: none"> ▪ Once the first cleaning phase is done, the unit will make an acoustic signal to let you know. ▪ You will be prompted to add rinse aid to the inside. ▪ The software will indicate how many single-measure dispensing bottles are needed.
4.		Open the unit door.

5.		Add rinse aid from the single-measure dispensing bottles to the inside of the oven cavity.
6.		Close the unit door.
7.		Wait for the last cleaning phase to be done (approx. 10 minutes).
8.		<ul style="list-style-type: none"> Once the last cleaning phase is done, the unit will make an acoustic signal to let you know. Follow the software's prompts.
9.		<ul style="list-style-type: none"> Open the unit door and check to make sure that everything has been cleaned properly. The oven cavity should be visibly clean and should not give off any smells typical of food leftovers or cleaning agents. Check the oven cavity to make sure that no foreign objects got in during rinsing. If there are any foreign objects, remove them. If additional cleaning is required, clean and rinse the oven cavity manually or by running a cleaning profile once again.
10.		Leave the unit door ajar in order to let the oven cavity dry out.

5.3 General Operator-Aided Cleaning Process Instructions

5.3.1 How to Semi-Automatically Clean the Oven Cavity

▲ For your safety when working with/on the combi oven

Before starting work, read and understand the rules, risks, and hazards specified in the 'For Your Safety on page 17' section and in these instructions and follow all the corresponding instructions without exception.

Procedures that you must be familiar with









You will need to be familiar with the following steps:

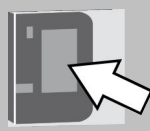





- Safely Opening and Closing the Unit Door 42
- Release the suction panel and lock it back in place 75

Prerequisites

- You must be familiar with how to use the software to such an extent that you will be able to access and start the various cleaning profiles, please refer to the combi oven's operating instructions.
- All food must have been taken out from the oven cavity. There must not be any foreign objects inside the oven cavity.
- All bakeware, sheet pans, and shelf grills, as well as any other accessories, must have been taken out from the oven cavity.
- The oven cavity drain must be clear. It must not be clogged or blocked by any residues. The strainer on the oven drain must be in place.
- The unit door's inner panes are properly locked in place.
- The suction panel is properly locked in place.
- The unit door must be closed.
- The recoil hand shower (optional) must have been flushed.
- You must supply the fluids required by the cleaning program you will be using. Please refer to 'Supplying Cleaning Agents' on page 62.

How to Semi-Automatically Clean the Oven Cavity

1.		Open the cleaning profile and start the cleaning sequence.
2.		Wait for the soaking phase to be done (approx. 10 minutes).
3.		Once the soaking phase is done, the unit will make an acoustic signal to let you know. You will be prompted to spray cleaning agent inside.
4.		Open the unit door.
5.		Swing the rack and the suction panel towards the inside of the oven cavity.
6.		Spray the oven cavity, the suction panel and the area behind it, the racks, and the oven drain with the cleaning agent inside the spray bottle.
7.		Lock the suction panel and the racks back in place.
8.		Close the unit door.
9.		Wait for the cleaning phase to be done (approx. 10 minutes).

10.		<p>Once the cleaning phase is done, the unit will make an acoustic signal to let you know. You will be prompted to rinse out the oven cavity.</p>
11.		<p>Open the unit door.</p>
12.		<p>Swing the rack and the suction panel towards the inside of the oven cavity once again.</p>
13.		<p>⚠ WARNING</p> <p>Risk of food being contaminated by cleaning agent or rinse aid if the unit is not completely rinsed out</p> <ul style="list-style-type: none"> ▪ If the unit does not have a pullout spray head, use an external water jet to rinse out the unit or thoroughly wipe the oven cavity, the accessories, and the area behind the suction panel with plenty of water and a soft cloth. <p>Use a water jet to thoroughly rinse the area behind the suction panel, the suction panel itself, the rack, the entire oven cavity, and the oven drain.</p>
14.		<p>Check to make sure that everything has been cleaned properly. The oven cavity should be visibly clean and should not give off any smells typical of food leftovers or cleaning agents. If additional cleaning is required, clean and rinse the oven cavity manually or by running a cleaning profile once again.</p>
15.		<p>Lock the suction panel and the racks back in place.</p>
16.		<p>Leave the unit door ajar in order to let the oven cavity dry out.</p>

5.3.2 How to Clean the Oven Cavity Section Behind the Suction Panel

⚠ For your safety when working with/on the combi oven

Before starting work, read and understand the rules, risks, and hazards specified in the 'For Your Safety on page 17' section and in these instructions and follow all the corresponding instructions without exception.

Procedures that you must be familiar with



You will need to be familiar with the following steps:

- Safely Opening and Closing the Unit Door 42
- Removing and Installing the Racks 50
- Release the suction panel and lock it back in place 75

Prerequisites

- The unit must be completely off.
- The oven cavity must have cooled down to a temperature of less than 140 °F since the last time it was used.
- You must supply the required cleaning agent in the spray bottle. Please refer to 'Supplying Cleaning Agents' on page 62.
- The oven cavity drain must be clear. It must not be clogged or blocked by any residues.
- The left rack must have been removed.

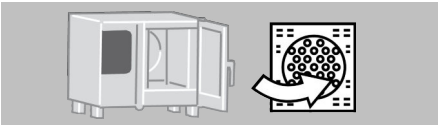
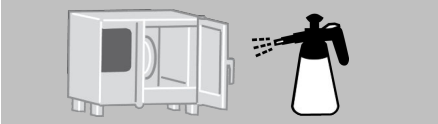
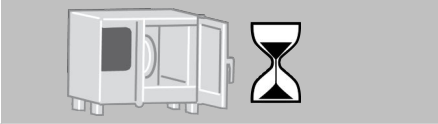
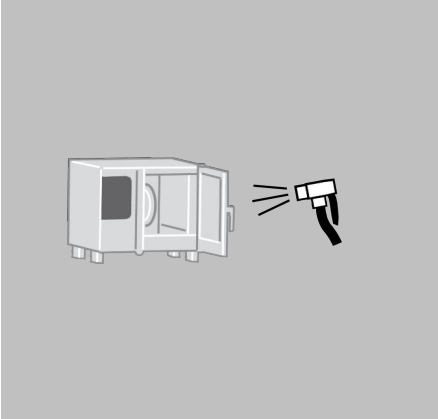
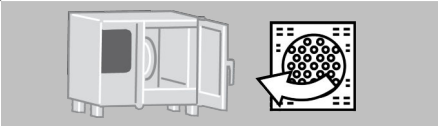
How to Clean the Oven Cavity Section Behind the Suction Panel

1.		Swing the suction panel towards the inside of the oven cavity.
2.		Spray the suction panel on all sides and the area behind it with the cleaning agent in the spray bottle.
3.		Let the cleaning agent work for 10 – 20 minutes.
4.		<p>⚠ WARNING</p> <p>Risk of food being contaminated by cleaning agent or rinse aid if the unit is not completely rinsed out</p> <ul style="list-style-type: none"> ▪ If the unit does not have a pullout spray head, use an external water jet to rinse out the unit or thoroughly wipe the oven cavity, the accessories, and the area behind the suction panel with plenty of water and a soft cloth. <p>Use a water jet to thoroughly rinse the area behind the suction panel, the suction panel from all sides, the entire oven cavity, and the oven drain. You can repeat the cleaning sequence if there is heavy soiling.</p>
5.		Lock the suction panel back in place.
6.		Leave the unit door ajar in order to let the oven cavity dry out.

5.3.3 How to Clean the Triple Glazing Door's Inner Panes and LED Strip

⚠ For your safety when working with/on the combi oven

Before starting work, read and understand the rules, risks, and hazards specified in the 'For Your Safety on page 17' section and in these instructions and follow all the corresponding instructions without exception.

Procedures that you must be familiar with

You will need to be familiar with the following steps:

- Safely Opening and Closing the Unit Door 42
- Releasing and locking the triple glazing door's inner pane and center pane 78

Prerequisites

- The oven cavity must have cooled down to the ambient temperature since the last time it was used.
- You must have the necessary cleaning agent, common household glass cleaner, ready.
- You must have several (at least three) clean, soft cloths ready.

How to Clean the Triple Glazing Door's Inner Panes and LED Strip

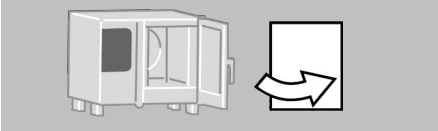
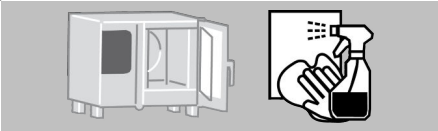
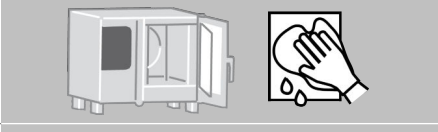
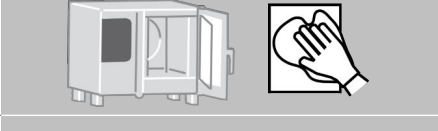
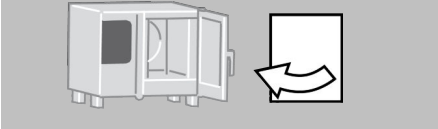
1.		Open the unit door and swing the triple glazing door's inner panes out.
2.		Clean both sides of the triple glazing door's inner panes, the outside of the outer pane, and the LED strip with a soft, clean cloth and the cleaning agent. Make sure not to scratch the glass.
3.		Wipe both sides of the triple glazing door's inner panes, the outside of the outer pane, and the LED strip clean with a soft, clean cloth and clean water.
4.		Dry both sides of the triple glazing door's inner panes, the outside of the outer pane, and the LED strip with a soft, clean cloth.
5.		<ul style="list-style-type: none"> ▪ Swing the triple glazing door's inner panes back in place and lock them into place. ▪ Exercise caution when performing this task in order to avoid crushing or cutting your hands and fingers.

5.3.4 How to Clean the Hygienic Plug-In Gasket Thoroughly

⚠ For your safety when working with/on the combi oven

Before starting work, read and understand the rules, risks, and hazards specified in the 'For Your Safety on page 17' section and in these instructions and follow all the corresponding instructions without exception.

Procedures that you must be familiar with





You will need to be familiar with the following steps:

- Safely Opening and Closing the Unit Door 42
- Removing and Installing the Hygienic Plug-In Gasket 77

Prerequisites

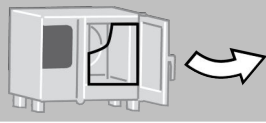
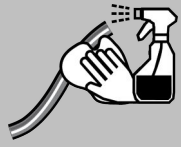
- The oven cavity must have cooled down to a temperature of less than 140 °F since the last time it was used.
- You must have the necessary cleaning agent, common household dishwashing liquid, ready.
- You must have several (at least three) clean, soft cloths ready.

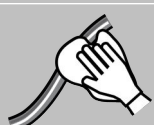
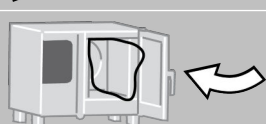
How to Clean the Hygienic Plug-In Gasket Thoroughly

1.		Open the unit door and remove the hygienic plug-in gasket.
2.		Clean the hygienic plug-in gasket with a soft, clean cloth and cleaning agent in a sink.
3.		Rinse the hygienic plug-in gasket with a soft, clean cloth and water in a sink.
4.		Thoroughly dry the hygienic plug-in gasket with a soft, clean cloth.
5.		Put the hygienic plug-in gasket back around the oven cavity.
6.		Leave the unit door ajar in order to let the hygienic plug-in gasket dry out completely.

5.4 Specific Cleaning Instructions

5.4.1 Release the suction panel and lock it back in place

⚠ For your safety when working with/on the combi oven

Before starting work, read and understand the rules, risks, and hazards specified in the 'For Your Safety on page 17' section and in these instructions and follow all the corresponding instructions without exception.

Procedures that you must be familiar with

You will need to be familiar with the following steps:

- Safely Opening and Closing the Unit Door 42
- Removing and Installing the Racks 50

Required tools

Wide slotted flat blade screwdriver

Prerequisites

- The unit must be completely off.
- The oven cavity must have cooled down to a temperature of less than 140 °F since the last time it was used.
- The left rack must have been removed.

Releasing and swinging out the suction panel

1.

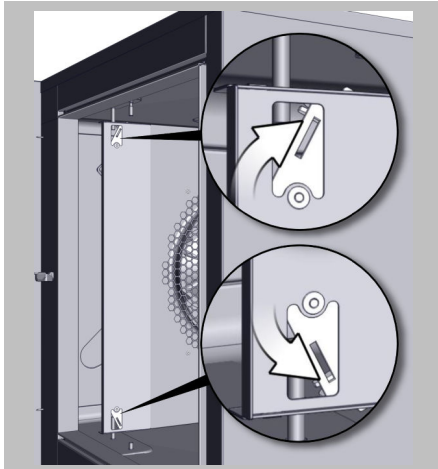

Release the upper and lower latches with the tool.

2.

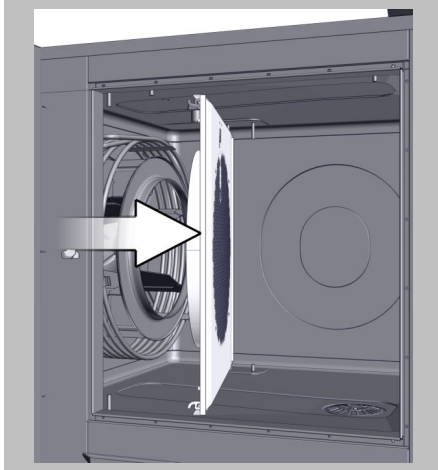

Swing the suction panel towards the inside of the oven cavity.

Locking the suction panel in place

1.

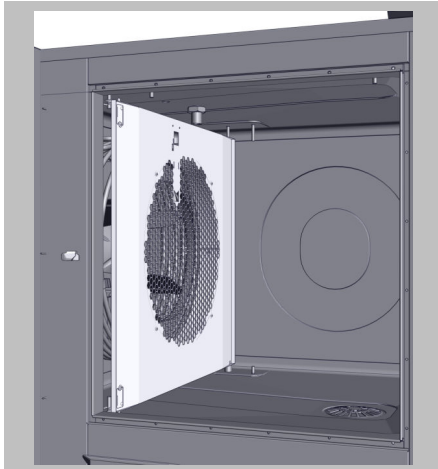

Follow the same steps used to release and swing out the suction panel, but in opposite order.

2.

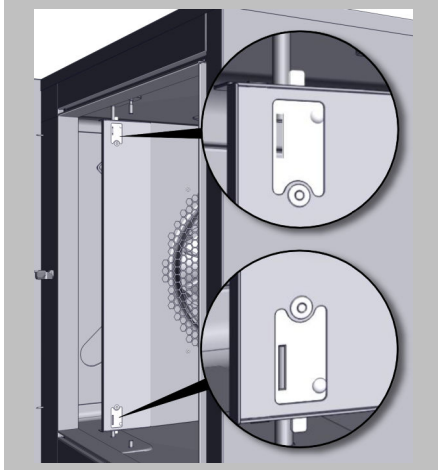

Check to make sure that the upper and lower latches are engaged.

5.4.2 Removing and Installing the Hygienic Plug-In Gasket

⚠ For your safety when working with/on the combi oven

Before starting work, read and understand the rules, risks, and hazards specified in the 'For Your Safety on page 17' section and in these instructions and follow all the corresponding instructions without exception.

Procedures that you must be familiar with

You will need to be familiar with the following steps:

- Safely Opening and Closing the Unit Door

42

Prerequisites

- The oven cavity must have cooled down to a temperature of less than 140 °F since the last time it was used.
- The unit door must be open.

Removing the hygienic plug-in gasket

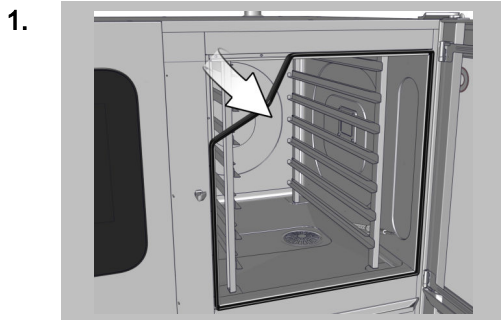

Pull out the hygienic plug-in gasket around the unit door opening. Start from the corners.

Installing the hygienic plug-in gasket

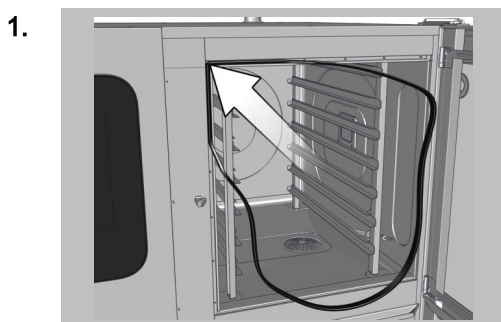

Start by putting the hygienic plug-in gasket back in place at all four corners. Start from one of the upper corners.

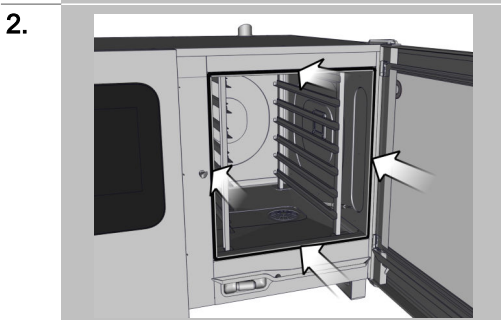

Once all four corners are in place, meticulously press the hygienic plug-in gasket into the rest of the guide. Make sure that the hygienic plug-in gasket is resting solidly against the guide and that there are no bends or kinks in it.

5.4.3 Releasing and locking the triple glazing door's inner pane and center pane

⚠ For your safety when working with/on the combi oven

Before starting work, read and understand the rules, risks, and hazards specified in the 'For Your Safety on page 17' section and in these instructions and follow all the corresponding instructions without exception.

Procedures that you must be familiar with

You will need to be familiar with the following steps:

- Safely Opening and Closing the Unit Door

42

Prerequisites

- The oven cavity must have cooled down to a temperature of less than 140 °F since the last time it was used.

Releasing and swinging out the inner pane and center pane

1.



Open the unit door.

2.

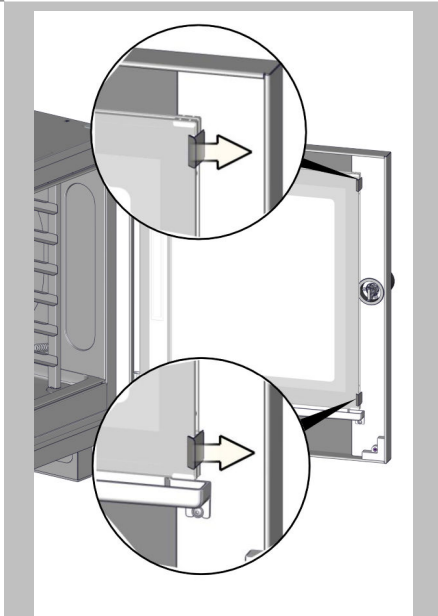

Release the inner pane by pushing the upper right and lower right spring clips to the side.

3.

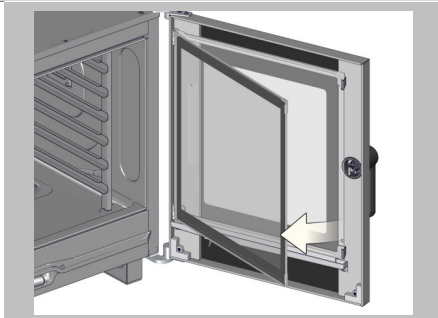

Carefully swing the inner pane out of its mount.

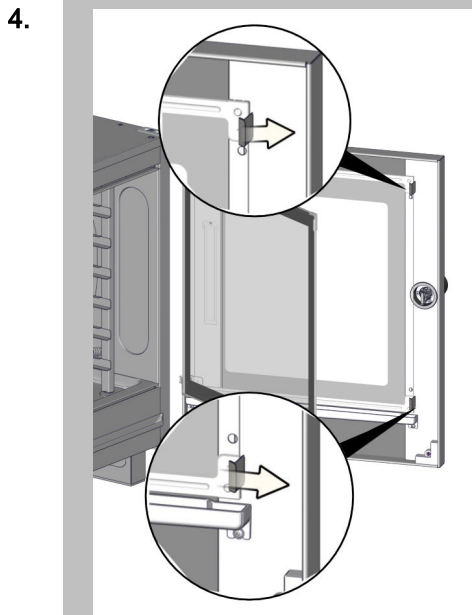

Release the center pane by pushing the upper right and lower right spring clips to the side.

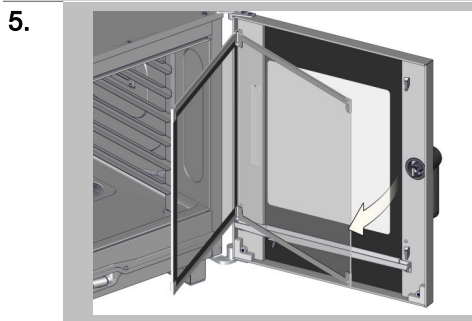

Carefully swing the center pane out of its mount.

Locking the inner pane and center pane

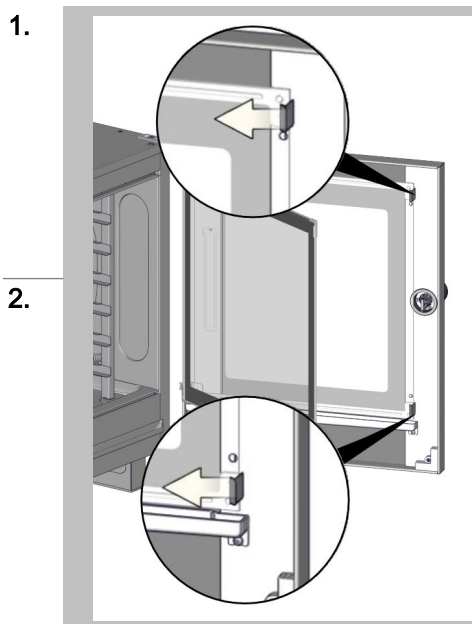

⚠ WARNING

Pinch point hazard (hand hazard)

- Be sure to exercise caution when performing this activity.
- Wear appropriate personal protective equipment.

Follow the same steps used to remove the inner pane, but in opposite order.

Check to make sure that the upper left and right spring clips are holding the inner pane correctly in position and that the lock on the right upper holder is closed. Do not close the unit door until they are!

5.4.4 Emptying and Cleaning the Grease Collection Canister (ConvoGrill Only)

▲ For your safety when working with/on the combi oven

Before starting work, read and understand the rules, risks, and hazards specified in the 'For Your Safety on page 17' section and in these instructions and follow all the corresponding instructions without exception.

Handling pumped-out grease / used grease

- Used oil and used grease must be disposed of in compliance with the relevant country-specific laws and regulations, as well as in compliance with all applicable rules and regulations set forth by the relevant local disposal companies and authorities.
- Do not pour used grease or used oil down the drain and into the sewer system.
- Do not use pumped-out grease / used grease to prepare meals.
- Collect used grease in appropriate containers and take it to the appropriate facility.
- The company operating the combi oven must brief all staff accordingly.

Required tools

- Large bottle brush
- Common household dishwashing liquid
- Container suitable for pumped-out grease (capacity >> 2.5 gallons)

Grease collection canister characteristics

Do not use any grease collection canisters other than the one included, as the included canister's material is designed to meet the requirements involved in holding hot grease.

Emptying and Cleaning the Grease Collection Canister

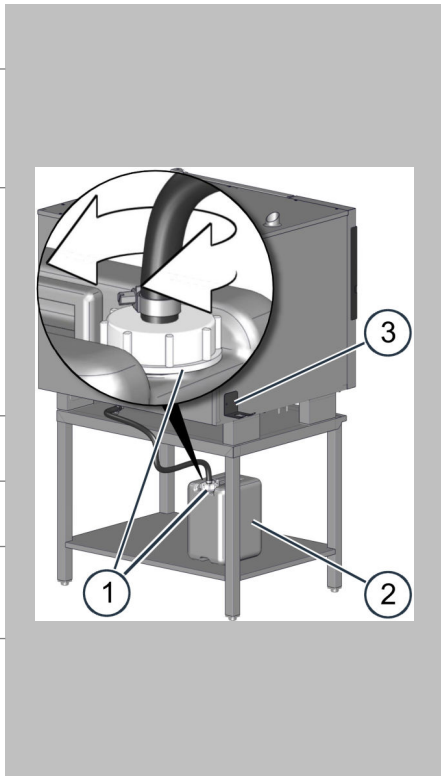
1.		Remove the screw closure (1) with the connected tube from the grease collection canister (2).
2.		Place the screw closure (1) with the connected tube – with the opening facing upward – in the forked holder (3). This will prevent grease from flowing out and falling onto the floor, creating a slip hazard.
3.		When handling the grease collection canister (2), make sure that no grease falls onto the floor, creating a slip hazard. This is especially important when moving the grease collection canister (2) while it is full and open. Pour the pumped-out grease from the grease collection canister (2) into the container for pumped-out grease. To do so, tip the grease collection canister (2) gradually in order to prevent the grease from sloshing.
4.		Clean the inside of the grease collection canister (2) with cleaning agent, plenty of hot water, and the bottle brush.
5.		Rinse the grease collection canister (2) with water and let the water drip out fully.
6.		Screw the screw closure (1) with the connected grease management tube back onto the grease collection canister (2).
7.		Place the grease collection canister (2) in an upright position on a flat, level surface next to the unit. The canister's (2) supporting surface must not be more than 6" above the contact point between the unit and its base. The operator's working area must be kept clear.

5.4.5 Replacing the rinse aid and cleaning agent canisters

⚠ For your safety when working with/on the combi oven

Before starting work, read and understand the rules, risks, and hazards specified in the 'For Your Safety on page 17' section and in these instructions and follow all the corresponding instructions without exception.

Required tools

- One empty canister (2.5 gallons) for ConvoCare rinse aid
- Enough (around 2.5 gallons) soft water (for specifications, please refer to the 'Water Quality' subsection of the 'Technical Data' section in the installation manual)
- ConvoCare Concentrate (0.7 pint)
- ConvoClean forte replacement canister

Preparing ConvoCare rinse aid in the canister

To prevent undesired foaming, follow the steps below when preparing rinse aid with ConvoCare concentrate and soft water:

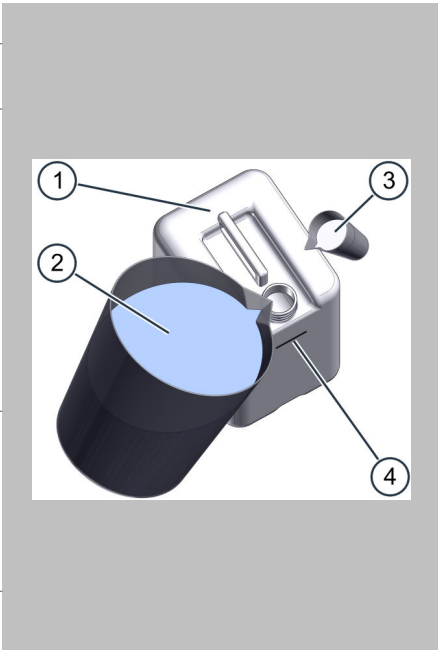
- | | | | |
|----|---|---|------------------------------|
| 1. |  | 2. | Open the empty canister (1). |
| 3. | | Fill the canister with soft water (2) all the way to just under the 2.5-gallon marking (4). | |
| | | ⚠ WARNING | |
| | | Risk of skin, eye, and respiratory tract irritation <ul style="list-style-type: none">▪ Do not let the rinse aid come into contact with your eyes, skin, or mucous membranes.▪ Do not inhale the rinse aid's vapors or mist.▪ Wear the required personal protective equipment. | |
| 4. | | Then carefully pour 0.7 pints of ConvoCare Concentrate (3) into the canister (1). | |
| 5. | Check the liquid level inside the canister: <ul style="list-style-type: none">▪ If the level is below the 2.5-gallon marking (4), carefully add the required amount of soft water (2).▪ If the level is above the 2.5-gallon marking (4), the rinse aid's concentration will be lower than specified. You can still use the rinse aid if this is the case! | | |
| | Close the canister and mix the liquids thoroughly by shaking it. | | |

Replacing the rinse aid and cleaning agent canisters

1.

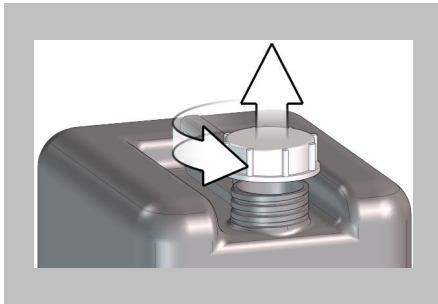

⚠ WARNING

Risk of chemical burns and skin, eye, and respiratory tract irritation

- Do not let the contents of the respective canister come into contact with skin, eyes or mucous membranes.
- Do not inhale escaping vapors.
- Wear appropriate personal protective equipment.

Remove the cap from the new canister.

2.

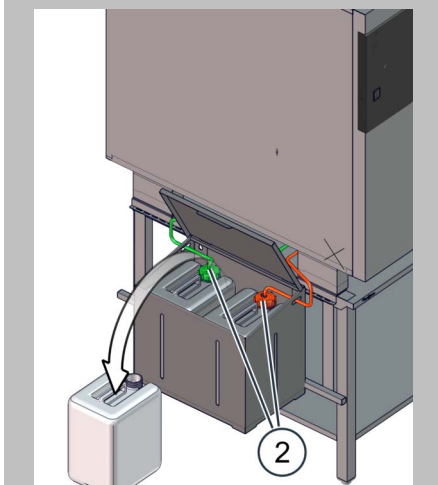

- Identify the canister that is connected to the associated connection at the bottom left side of the unit by means of the colored tube.

- Cleaning agent: red hose, connection G
- Rinse aid: green hose, connection F

- Unscrew the supply tube (2) together with the suction nozzle from the respective canister.
- Remove the empty canister.

3.

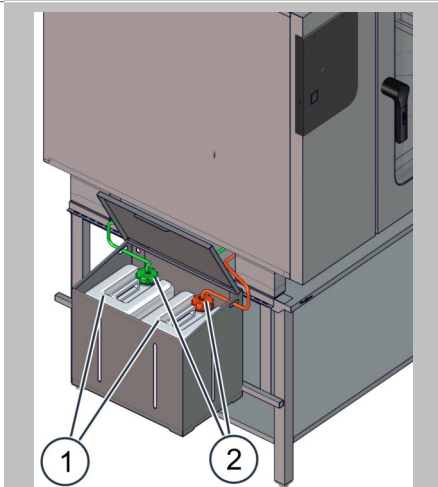

- Put the new, full canister (1) in place.

- Insert the supply tube, together with the suction nozzle (2), into the full canister (1) and screw it in place.

- Cleaning agent: red
- Rinse aid: green

- Make sure that the tube is routed without any kinks and that the vent opening on the canister's cap is open and clear.

4.

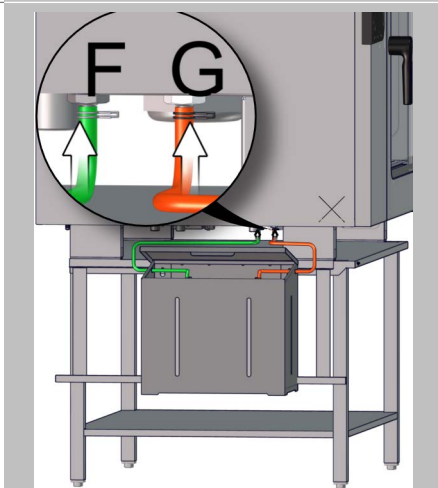

- Check to make sure that the canisters are set up correctly:

- The canisters' supporting surface must not be higher than the edge where the feet and the unit case meet.
- The canisters' supporting surface must not be more than 3 feet below this edge.

- Check to make sure that the tube is connected to the right connection.

- The rinse aid must go to unit connection F. (indicated by a green color).
- The cleaning agent must go to unit connection G. (indicated by a red color).

5.4.6 Adding Cleaning Agent from Single-Measure Dispensing Bottles to the Inside of the Oven Cavity

▲ For your safety when working with/on the combi oven

Before starting work, read and understand the rules, risks, and hazards specified in the 'For Your Safety on page 17' section and in these instructions and follow all the corresponding instructions without exception.

Procedures that you must be familiar with

You will need to be familiar with the following steps:

- Safely Opening and Closing the Unit Door 42
- Supplying Cleaning Agents 62

Prerequisites

- You must have started a cleaning profile that uses fully automatic oven cleaning with single-measure dispensing. The software has prompted you to add either cleaning agent or rinse aid from a single-measure dispensing bottle to the inside of the oven cavity.
- You must have the necessary single-measure dispensing bottles containing cleaning agent and rinse aid ready to go as required by the cleaning program you are using. Please refer to 'Supplying Cleaning Agents' on page 62.

Adding Cleaning Agent from Single-Measure Dispensing Bottles to the Inside of the Oven Cavity

1.

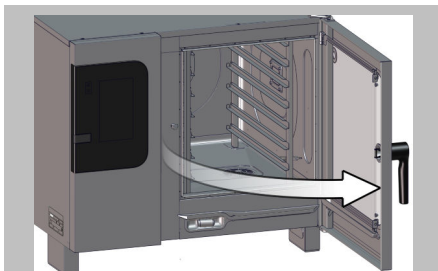

- Do not open the unit door until you are prompted to do so by the software during the fully automatic oven cleaning sequence.
- Follow the software's prompts.
- Depending on where in the cleaning sequence you are, grab a single-measure dispensing bottle with cleaning agent or a single-measure dispensing bottle with rinse aid.

2.

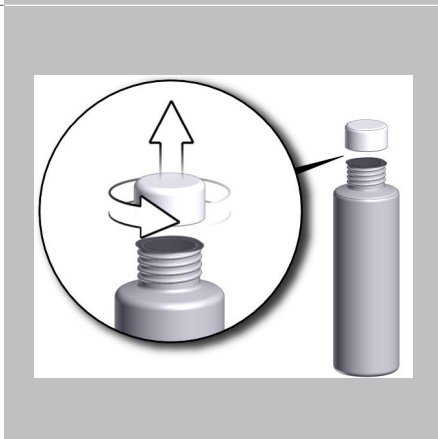

▲ WARNING

Risk of chemical burns and skin, eye, and respiratory tract irritation

- Do not let the cleaning agents or rinse aid from single-dose dispensing bottles come into contact with your eyes, skin, or mucous membranes.
- Do not open the unit door during the fully automatic oven cleaning process UNTIL prompted to do so by the software.
- Wear the required personal protective equipment.
- Unscrew the single-measure dispensing bottle's cap.
- Make sure that the seal on the bottle remains undamaged.

3.

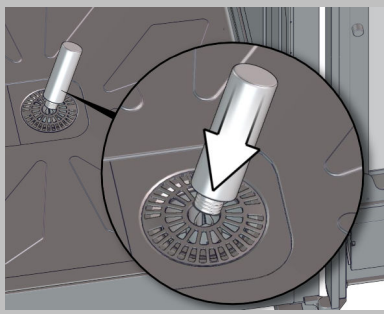

Vertically push the bottle into the pointed tip at the center of the oven drain so that the tip will pierce the seal.

4.

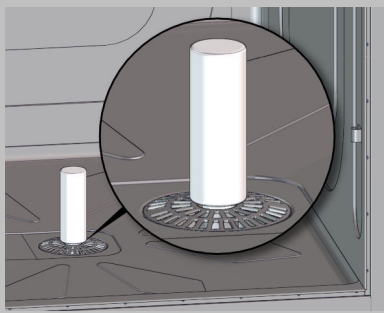

- Let the bottle sit vertically on the pointed tip for about 10 seconds so that there will be enough time for all the liquid to come out.
- Visually check whether all the liquid has come out. The single-measure dispensing bottle is made of a transparent material that makes it possible to see whether there is any liquid still inside.
- If necessary, squeeze the remaining liquid out of the single-measure dispensing bottle while it is still on the pointed tip.

5.

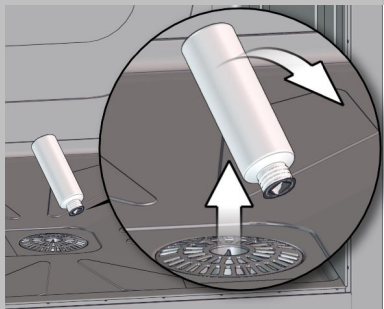

⚠ WARNING

Risk of food being contaminated by cleaning agent or rinse aid

- Do not put empty single-measure dispensing bottles down on the work surface, as drops of cleaning agent or rinse aid may run down along the outside of the bottles.
- Use plenty of clean water to wipe clean all surfaces outside the oven cavity that may have cleaning agents or rinse aid on them and on which food will be prepared afterwards.
- Once you are done, carefully remove the bottle from the pointed tip.
- Remove the bottle from the oven cavity.
- Repeat steps 2 through 5 if the software prompts you to use more than one single-measure dispensing bottle to add cleaning agent or rinse aid to the inside of the oven cavity.

6.

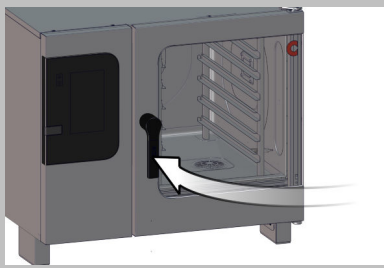

Close the unit door.

6 How to Perform Maintenance on the Combi Oven

6.1 Maintenance Basics

6.1.1 Contact Customer Service

Required information

Please have the following unit information ready when contacting Customer Service:

- The unit's item number (please refer to 'Identifying Your Combi Oven' on page 7)
- The unit's serial number (please refer to 'Identifying Your Combi Oven' on page 7)

Contact information for Convotherm in Germany

Welbilt Deutschland GmbH
Talstraße 35
82436 Eglfing
Germany

Headquarters	
Phone	(+49) (0) 8847 67 - 0
Fax	(+49) (0) 8847 414
e-mail	info@convotherm.de
Website	www.convotherm.com www.welbilt.com
Download Center for documents (spare parts lists, circuit diagrams, service manuals, brochures, instructions)	www.convotherm.com/resources www.convotherm.com/Service#Service
Sales	
Website	www.welbilt.us/Sales/Sales-Locators#Rep-Locator
Representative / dealer contact information	Callcenter@welbilt.com
Customer Service	
Phone	(+1) 844 724-2273
e-mail	ConvothermSVC@welbilt.com

6.1.2 Warranty information

Warranty information

For warranty information, see the 'Placement into operation' chapter in the installation manual.

Further information on the warranty conditions can be found on the Internet at www.convotherm.com

6.1.3 Maintenance Schedule

Rules for maintaining the unit

In order to be able to safely operate the combi oven, maintenance must be performed on it on a regular basis. This includes both maintenance work that can be performed by the operator and maintenance work that should be performed exclusively by a qualified service technician from an authorized service company (Customer Service).

The following applies to all maintenance:

- The unit must be cleaned after maintenance work.

Maintenance work that can be carried out by the operator.

What needs to be serviced?	When?	Required parts
Replacing the hygienic removable gasket	When the hygienic plug-in gasket has cracks or is greasy	As specified in the parts list: One (1) hygienic plug-in gasket
The core temperature probe's and sous vide probe's proper functioning	Put the probes in boiling water and check the temperature display once a week	-

Maintenance that must be performed by Customer Service

What needs to be serviced?	How often? / When?
General maintenance	Annually
The water treatment system needs to be readjusted	If there is a white film inside the oven cavity
Boiler descaling	After being prompted by the unit
Calibration of the optional core temperature probe	Annually

6.2 Troubleshooting

6.2.1 Error codes

Errors and required responses

The following table lists the errors that you will be able to fix yourself under certain circumstances. If the combi oven keeps showing the error even after you attempt to fix it, contact Customer Service. If any error messages other than the ones listed here appear, contact Customer Service.

Error No.	Error description	Required response
E01.x	Not enough water	Open the water connection valve(s)
E02	Wiring compartment temperature too high	<ul style="list-style-type: none"> ▪ Clean the fan grill on the bottom of the unit ▪ Clear the area around the air intake on the bottom of the unit
E05	No gas	Open the gas shut-off device and restart the unit
E10	Water filter fault	Replace the water treatment system cartridge
E34.0	Boiler pump fault	Disconnect the unit from the outlet for approx. 10 seconds and restart it
E58.0	Cleaning agent dispensing pump fault	<ul style="list-style-type: none"> ▪ Fill the canister with the appropriate cleaning agent and restart the unit ▪ If necessary, repeat until the lines are filled with cleaning agent
E59.0	Rinse aid dispensing pump fault	<ul style="list-style-type: none"> ▪ Fill the canister with rinse aid and restart the unit ▪ If necessary, repeat until the lines are filled with rinse aid
E81.0	Cooking mode error	Write the cooking profile again
E99	Communications dropped out	Disconnect the unit from the outlet for approx. 10 seconds and restart it
E99.9	Initialization error	Disconnect the unit from the outlet for approx. 10 seconds and restart it

Errors and required responses for ConvoSense

The following table lists the errors that you will be able to fix yourself under certain circumstances when cooking with the ConvoSense assistance system. If the combi oven keeps showing the error even after you attempt to fix it, contact Customer Service.

If any error messages other than the ones listed here appear, contact Customer Service.

Error No.	Error description	Required response
E40.99.1	Communication error between easyTouch and ConvoSense module	Disconnect the unit from the outlet for approx. 2 minutes and restart it
E40.99.2	Communication error between easyTouch and cloud server	Check cable connection
E40.99.3	Communication error between ConvoSense module and cloud server	Check cable connection
E40.99.4	Communication error between easyTouch and cloud server	Disconnect the unit from the outlet for approx. 2 minutes and restart it
E40.99.5	Connection to cloud provider offline	Disconnect the unit from the outlet for approx. 2 minutes and restart it
E40.99.6	WiFi connection lost	Turn off the wireless router and turn it back on
E42.1.1	Not enough brightness for camera	Clean the camera
E42.1.2	Excessive ambient brightness for camera/reflections	Prevent reflections
E42.1.3	Camera image cannot be recognized	Clean the camera
E42.1.4	Camera not working	Disconnect the unit from the outlet for approx. 2 minutes and restart it
E42.3.0	Camera too hot	Close the unit door and wait until the camera has cooled down

Further information

For more detailed information on error codes and their resolutions, visit our service page on the Internet at '<https://pim.myconvotherm.de/online-help/index.html>'.

Or scan the QR code below to access the page:



6.2.2 Emergency Mode

Running the combi oven in emergency mode

The combi oven features an emergency mode in order to allow you to keep using it if there is an error or fault that cannot be fixed right away.

This mode will let you keep running the unit (with a number of limitations) even when there is a malfunction.

Always notify Customer Service!

Prerequisites

- The unit is malfunctioning.
- An acoustic signal is emitted.
- An error code is shown on the display.

Running the unit in emergency mode

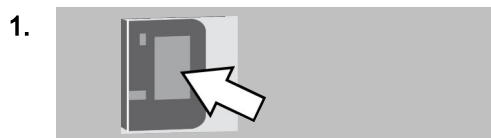

Confirm the error being displayed and start a cooking or cleaning profile that is available.

Limitations

- Cooking times may be longer and cooking results may be uneven. Because of this, pay special attention to the cooking sequence and to how well-cooked your product is.
- The unit may need to use more water than usual.
- Fully automatic and semi-automatic cleaning may not be available or may only be possible to a limited extent.
- It may not be possible to use the core temperature probe and the optional sous vide probe in certain cases.
- The only functions available will be those not affected by the fault, error, or malfunction that has occurred.

Functions available in emergency mode

The following table lists the errors after which the unit can still be used in emergency mode if the error cannot be fixed right away.

Error No.	E B	E S	G B	G S	Functions available in emergency mode	Limitations / Procedure
E00.0	x	x	x	x	All functions	The previous error has been fixed or is no longer present
E01.x	x	x	x	x	<ul style="list-style-type: none"> ▪ Hot air at up to 284 °F ▪ Hot air Delta-T cooking at up to 284 °F ▪ Hot air Cook&Hold at up to 284 °F ▪ Smoker ▪ Hot air ecoCooking at up to 284 °F 	<ul style="list-style-type: none"> ▪ No boiler pre-heating ▪ Cleaning will not be possible
E03.x	x	-	x	-	<ul style="list-style-type: none"> ▪ Steam at exactly 212 °F ▪ Smoker 	<ul style="list-style-type: none"> ▪ Longer cooking time ▪ Uneven cooking results are possible ▪ Boiler heating element only, no oven heating element ▪ Cleaning will not be possible
E05.1.x E05.3.x	#	#	x	-	<ul style="list-style-type: none"> ▪ Steam at exactly 212 °F ▪ Smoker 	Cleaning will not be possible
E05.2.x	#	#	x	#	<ul style="list-style-type: none"> ▪ Hot air ▪ Hot air Delta-T cooking ▪ Hot air Cook&Hold ▪ Smoker ▪ Crisp&Tasty ▪ Hot air ecoCooking 	<ul style="list-style-type: none"> ▪ No boiler pre-heating ▪ Cleaning will not be possible
E10	x	x	x	x	All functions	-
E21.1	x	-	x	-	<ul style="list-style-type: none"> ▪ Steam at exactly 212 °F ▪ Smoker 	<ul style="list-style-type: none"> ▪ Longer cooking time ▪ Uneven cooking results are possible ▪ Boiler heating element only, no oven heating element ▪ Cleaning will not be possible
E21.3	x	x	x	x	<ul style="list-style-type: none"> ▪ Steam at exactly 212 °F ▪ Smoker 	Cleaning will not be possible
E22.1.x E22.2.x E22.3.x E22.4.x	x	x	x	x	<ul style="list-style-type: none"> ▪ All functions, EXCEPT: <ul style="list-style-type: none"> ▪ Steam Delta-T cooking ▪ Combi-steam Delta-T cooking ▪ Hot air Delta-T cooking 	No functions with core temperature probe or sous-vide probe if there are less than two measuring points available
E22.5.x	x	x	x	x	<ul style="list-style-type: none"> ▪ All functions, EXCEPT: <ul style="list-style-type: none"> ▪ Steam Delta-T cooking ▪ Combi-steam Delta-T cooking ▪ Hot air Delta-T cooking 	No functions with core temperature probe or sous-vide probe
E23.1 E23.3	x	#	x	#	<ul style="list-style-type: none"> ▪ Hot air ▪ Hot air Delta-T cooking ▪ Hot air Cook&Hold ▪ Smoker ▪ Crisp&Tasty ▪ Hot air ecoCooking 	<ul style="list-style-type: none"> ▪ No boiler pre-heating ▪ Cleaning will not be possible

Error No.	E B	E S	G B	G S	Functions available in emergency mode	Limitations / Procedure
E24.1 E24.3	x	x	x	x	<ul style="list-style-type: none"> ▪ Hot air ▪ Hot air Delta-T cooking ▪ Hot air Cook&Hold ▪ Smoker ▪ Crisp&Tasty ▪ Hot air ecoCooking 	Cleaning will not be possible
E25.1 E25.3	x	x	x	x	<ul style="list-style-type: none"> ▪ Hot air at up to 284 °F ▪ Hot air Delta-T cooking at up to 284 °F ▪ Hot air Cook&Hold at up to 284 °F ▪ Smoker ▪ Hot air ecoCooking at up to 284 °F 	<ul style="list-style-type: none"> ▪ Increased water consumption due to continuous collector cooling ▪ Cleaning will not be possible
E26.1 E26.3	x	#	x	#	<ul style="list-style-type: none"> ▪ Hot air ▪ Hot air Delta-T cooking ▪ Hot air Cook&Hold ▪ Smoker ▪ Crisp&Tasty ▪ Hot air ecoCooking 	<ul style="list-style-type: none"> ▪ No boiler pre-heating ▪ Cleaning will not be possible
E27.1 E27.3 E27.4	x	x	x	x	All functions	-
E28.1.x	x	-	#	#	<ul style="list-style-type: none"> ▪ Steam at less than 212 °F ▪ Steam Delta-T cooking at less than 212 °F ▪ Steam Cook&Hold at less than 212 °F ▪ Manual steaming 	Cleaning will not be possible
E28.2.1 E28.2.3	x	#	#	#	<ul style="list-style-type: none"> ▪ Hot air ▪ Hot air Delta-T cooking ▪ Hot air Cook&Hold ▪ Smoker ▪ Crisp&Tasty ▪ Hot air ecoCooking 	Cleaning will not be possible
E30.1 E30.3	x	x	x	x	<ul style="list-style-type: none"> ▪ All functions, EXCEPT: <ul style="list-style-type: none"> ▪ Fully automatic oven cleaning 	Only affects cleaning
E33.0	x	#	x	#	<ul style="list-style-type: none"> ▪ Hot air ▪ Hot air Cook&Hold ▪ Smoker ▪ Crisp&Tasty ▪ Hot air ecoCooking 	<ul style="list-style-type: none"> ▪ No boiler pre-heating ▪ Cleaning will not be possible
E34.0	x	#	x	#	<ul style="list-style-type: none"> ▪ All functions, EXCEPT: <ul style="list-style-type: none"> ▪ Fully automatic oven cleaning ▪ Semi-automatic oven cleaning 	<ul style="list-style-type: none"> ▪ No boiler rinsing ▪ Affects cleaning
E35.0	x	x	x	x	<ul style="list-style-type: none"> ▪ All functions, EXCEPT: <ul style="list-style-type: none"> ▪ Crisp&Tasty ▪ Fully automatic oven cleaning ▪ Semi-automatic oven cleaning 	Affects cleaning and Crisp&Tasty
E58.0	x	x	x	x	All functions	Fault relevant only to fully automatic cleaning with connected canisters
E59.0	x	x	x	x	All functions	Fault relevant only to fully automatic cleaning with connected canisters
E61.0	x	x	x	x	<ul style="list-style-type: none"> ▪ All functions, EXCEPT: <ul style="list-style-type: none"> ▪ Fully automatic oven cleaning ▪ Semi-automatic oven cleaning 	Only affects cleaning

Error No.	E B	E S	G B	G S	Functions available in emergency mode	Limitations / Procedure
E62.0	x	x	x	x	<ul style="list-style-type: none"> ▪ All functions, EXCEPT: <ul style="list-style-type: none"> ▪ Fully automatic oven cleaning ▪ Semi-automatic oven cleaning 	Only affects cleaning
E63.0	#	x	#	x	<ul style="list-style-type: none"> ▪ Hot air ▪ Hot air Delta-T cooking ▪ Hot air Cook&Hold ▪ Smoker ▪ Crisp&Tasty ▪ Hot air ecoCooking 	<ul style="list-style-type: none"> ▪ No boiler pre-heating ▪ Cleaning will not be possible
E72.x	x	x	x	x	All functions	-
E73.1	x	x	x	x	All functions	-
E91.x	x	x	x	x	All functions	-
E92.x	x	x	x	x	All functions	-
E200.x	x	x	x	x	All functions	-

x Emergency mode available

- Emergency mode unavailable

This unit model does not feature this error message, meaning that the corresponding error/fault will not limit the available functions or their parameters (the restrictions in the table apply exclusively to the other unit models).

6.2.3 Problems During Operation

Problems with the food being cooked

Problem	Possible cause	Required response
Irregular browning	The suction panel is not closed properly	'Release the suction panel and lock it back in place' on page 75
	The oven cavity is not pre-heated	Pre-heat the oven cavity
	The oven temperature is too high	Select a lower cooking temperature and cook the food longer
	The heating system is malfunctioning partially or entirely	Contact Customer Service

Problems with the unit

Problem	Possible cause	Required response
The unit does not respond to input for 10 – 20 seconds	Program crash	Press and hold the ON/OFF button for five seconds or disconnect the unit from the outlet for five seconds
With ConvoSense only: The unit is not recognizing food	With ConvoSense only: The camera is not working	With ConvoSense only: <ul style="list-style-type: none"> ▪ Check the network connection ▪ Clean the outside of the camera
The unit cannot be turned on or off anymore	The ON/OFF button is locked for three seconds	Try again after three seconds.

Problem	Possible cause	Required response
Water is coming out from under the unit when the unit door is closed	Regardless of the cause	CAUTION! Contamination hazard Destroy all food that has been in contact with the water.
	The drain pipe or wastewater system is clogged or constricted	<ul style="list-style-type: none"> Check the drain pipe and the on-site wastewater system and clean if necessary Use a funnel waste trap if necessary
	Non-detachable drain connection in units with fully automatic or semi-automatic oven cleaning	
	The air vent is clogged or covered	Remove the object clogging or covering it
	The unit drain is clogged	Clean the unit drain
In EB/GB models: Water is sprayed into the oven cavity during operation	In EB/GB models: The automatic boiler rinsing system has not been run on a daily basis	In EB/GB models: Empty and rinse out the boiler
There is water inside the oven cavity	The oven drain is clogged	Flush the oven drain
Steam comes out from the dry air intake on top of the unit.	Malfunctioning valve in dry air intake	WARNING! Risk of scalding posed by hot steam Contact Customer Service
A lot of steam is coming out from the sides of the closed unit door during operation.	Faulty door gasket	<ul style="list-style-type: none"> Check the hygienic removable gasket for damage and replace it if necessary Contact Customer Service if there is no apparent cause for the problem

Problems during cleaning

Problem	Possible cause	Required response
Black spots inside the oven cavity	Wrong cleaning agent	<ul style="list-style-type: none"> Use ConvoClean forte for fully automatic oven cleaning with canisters Use ConvoClean forte S for fully automatic oven cleaning with single-measure dispensing Use ConvoClean forte or ConvoClean new for semi-automatic oven cleaning
	The water is too hard	Adjust the water hardness; see 'Technical Data' in the installation manual
Poor cleaning results	The wrong soiling level has been set	Select a higher cleaning level
	The wrong cleaning agent was used	<ul style="list-style-type: none"> Use ConvoClean forte or ConvoClean new for fully automatic oven cleaning with canisters Use ConvoClean forte S or ConvoClean new S for fully automatic oven cleaning with single-measure dispensing Use ConvoClean forte or ConvoClean new for semi-automatic oven cleaning

What to do in the event of a power outage

During a cooking sequence:

- After a power outage, the cooking process will be automatically resumed if the downtime is shorter than five minutes. This will prevent bacterial growth in the food.

During a fully automatic cleaning sequence:

- After a power outage, the cleaning process will be automatically resumed in a defined state. Automatic safety rinsing is carried out so that no cleaning agent mixture remains in the oven cavity.
- If the sequence is manually cancelled, you will need to rinse the oven cavity manually.

6.3 Maintenance Work

6.3.1 Replacing the hygienic removable gasket

⚠ For your safety when working with/on the combi oven

Before starting work, read and understand the rules, risks, and hazards specified in the 'For Your Safety on page 17' section and in these instructions and follow all the corresponding instructions without exception.

Procedures that you must be familiar with

You will need to be familiar with the following steps:

- Safely Opening and Closing the Unit Door 42
- Removing and Installing the Hygienic Plug-In Gasket 77

Spare parts included

As indicated in the spare parts list, the required spare part is:

- One (1) hygienic plug-in gasket

Prerequisites

- The oven cavity must have cooled down to a temperature of less than 140 °F since the last time it was used.
- The unit door must be open.
- The new gasket has been inspected for damage and is not damaged.

Replacing the hygienic removable gasket

To remove the old hygienic plug-in gasket and install the new one, follow the steps described in 'Removing and Installing the Hygienic Plug-In Gasket' on page 77.

Combi Oven
Convotherm maxx pro

Table-top models

Serial No.

Item no.

Order No.

Additional technical documentation can be found in the download center at :
www.convotherm.com



Welbilt's portfolio of award-winning brands includes **Cleveland™**, **Convotherm®**, **Crystal Tips®**, **Delfield®**, **Frymaster®**, **Garland®**, **Lincoln™**, **Merco®**, **Merrychef®**, **Multiplex®** and **Wmaxx™**. Supported by service brands: **KitchenCare®**, aftermarket service and **KitchenConnect®**, cloud-based open platform.

Bringing innovation to the table • welbilt.com