



**Charbroiler/Griddles**  
*Models CE-CN-0350-G, 0610-D*  
*Items 41885, 41886*  
**Instruction Manual**



**STOP**  
**DO NOT RETURN**  
**THIS PRODUCT TO THE STORE**

For questions or assistance with this product call OMCAN Toll Free:  
1 800 465 0234  
Customer Service  
or  
visit the Support section of  
[www.omcan.com](http://www.omcan.com)

*Revised - 03/27/2018*



Toll Free: 1-800-465-0234  
Fax: 905-607-0234  
Email: [service@omcan.com](mailto:service@omcan.com)  
[www.omcan.com](http://www.omcan.com)

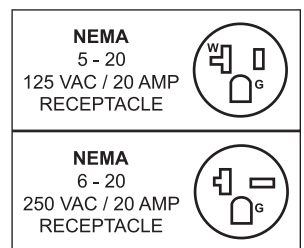

# ***Table of Contents***

Model CE-CN-0350-G / Model CE-CN-0610-D

---

<b>Section</b>	<b>Page</b>
General Information -----	3 - 4
Safety and Warranty -----	4 - 5
Technical Specifications -----	5
Operation -----	6
Maintenance -----	6 - 7
Parts Breakdown -----	8 - 10
Electrical Schematics -----	11 - 12
Notes -----	13 - 14
Warranty Registration -----	15



# General Information

---

Omcan Manufacturing and Distributing Company Inc., Food Machinery of America, Inc. dba Omcan and Omcan Inc. are not responsible for any harm or injury caused due to any person's improper or negligent use of this equipment. The product shall only be operated by someone over the age of 18, of sound mind, and not under the influence of any drugs or alcohol, who has been trained in the correct operation of this machine, and is wearing authorized, proper safety clothing. Any modification to the machine voids any warranty, and may cause harm to individuals using the machine or in the vicinity of the machine while in operation.

## CHECK PACKAGE UPON ARRIVAL

Upon receipt of an Omcan shipment please inspect for external damage. If no damage is evident on the external packaging, open carton to ensure all ordered items are within the box, and there is no concealed damage to the machine. If the package has suffered rough handling, bumps or damage (visible or concealed), please note it on the bill of lading before accepting the delivery and contact Omcan within 24 hours, so we may initiate a claim with the carrier. A detailed report on the extent of the damage caused to the machine must be filled out within three days, from the delivery date shown in the shipping documents. Omcan has no recourse for damaged products that were shipped collect or third party.

**Before operating any equipment, always read and familiarize yourself with all operation and safety instructions.**

Omcan would like to thank you for purchasing this machine. It's of the utmost importance to save these instructions for future reference. Also save the original box and packaging for shipping the equipment if servicing or returning of the machine is required.

---

Omcan Fabrication et distribution Compañie Limité et Food Machinery d'Amérique, dba Omcan et Omcan Inc. ne sont pas responsables de tout dommage ou blessure causé du fait que toute personne ait utilisé cet équipement de façon irrégulière. Le produit ne doit être exploité que par quelqu'un de plus de 18 ans, saine d'esprit, et pas sous l'influence d'une drogue ou d'alcool, qui a été formé pour utiliser cette machine correctement, et est vêtu de vêtements de sécurité approprié. Toute modification de la machine annule toute garantie, et peut causer un préjudice à des personnes utilisant la machine ou des personnes à proximité de la machine pendant son fonctionnement.

## VÉRIFIEZ LE COLIS DÈS RÉCEPTION

Dès réception d'une expédition d'Omcan veuillez inspecter pour dommages externes. Si aucun dommage n'est visible sur l'emballage externe, ouvrez le carton afin de s'assurer que tous les éléments commandés sont dans la boîte, et il n'y a aucun dommage dissimulé à la machine. Si le colis n'a subi aucune mauvaises manipulations, de bosses ou de dommages (visible ou cachée), notez-le sur le bond de livraison avant d'accepter la livraison et contactez Omcan dans les 24 heures qui suivent, pour que nous puissions engager une réclamation auprès du transporteur. Un rapport détaillé sur l'étendue des dommages causés à la machine doit être rempli dans un délai de trois jours, à compter de la date de livraison indiquée dans les documents d'expédition. Omcan n'a aucun droit de recours pour les produits endommagés qui ont été expédiés ou cueilli par un tiers transporteur.

# ***General Information***

---

**Avant d'utiliser n'importe quel équipement, toujours lire et vous familiariser avec toutes les opérations et les consignes de sécurité.**

**Omcán voudrais vous remercier d'avoir choisi cette machine. Il est primordial de conserver ces instructions pour une référence ultérieure. Également conservez la boîte originale et l'emballage pour l'expédition de l'équipement si l'entretien ou le retour de la machine est nécessaire.**

---

**Omcán Empresa De Fabricación Y Distribución Inc. Y Maquinaria De Alimentos De América, Inc. dba Omcán y Omcán Inc. no son responsables de ningún daño o perjuicio causado por cualquier persona inadecuada o el uso descuidado de este equipo. El producto solo podrá ser operado por una persona mayor de 18 años, en su sano juicio y no bajo alguna influencia de droga o alcohol, y que este ha sido entrenado en el correcto funcionamiento de esta máquina, y ésta usando ropa apropiada y autorizada. Cualquier modificación a la máquina anula la garantía y puede causar daños a las personas usando la máquina mientras esta en el funcionamiento.**

## **REVISE EL PAQUETE A SU LLEGADA**

**Tras la recepción de un envío Omcán favor inspeccionar daños externos. Si no hay daños evidentes en el empaque exterior, abra el cartón para asegurarse que todos los artículos solicitados estén dentro de la caja y no encuentre daños ocultos en la máquina. Si el paquete ha sufrido un manejo de poco cuidado, golpes o daños (visible o oculto) por favor anote en la factura antes de aceptar la entrega y contacte Omcán dentro de las 24 horas, de modo que podamos iniciar una reclamación con la compañía. Un informe detallado sobre los daños causados a la máquina debe ser llenado en el plazo de tres días, desde la fecha de entrega que se muestra en los documentos de envío. Omcán no tiene ningún recurso por productos dañados que se enviaron a recoger por terceros.**

**Antes de utilizar cualquier equipo, siempre lea y familiarizarse con todas las instrucciones de funcionamiento y seguridad.**

**Omcán le gustaría darle las gracias por la compra de esta máquina. Es de la mayor importancia para salvar estas instrucciones para futuras consultas. Además, guarda la caja original y el embalaje para el envío del equipo si servicio técnico o devolución de la máquina que se requiere.**

# ***Safety and Warranty***

---

## **SAFETY**

**Please take notice that the unit will still be too hot to handle immediately after use.**

**If the power cord is damaged, it must be replaced by qualified technician.**



# Safety and Warranty

## 1 YEAR PARTS AND LABOUR WARRANTY

Within the warranty period, contact Omcan Inc. at 1-800-465-0234 to schedule an Omcan authorized service technician to repair the equipment locally.

Unauthorized maintenance will void the warranty. Warranty covers electrical and part failures, not improper use.

Please see [www.omcan.com/warranty.html](http://www.omcan.com/warranty.html) for complete info.

### WARNING:

The packaging components (cardboard, polyethylene, and others) are classified as normal solid urban waste and can therefore be disposed of without difficulty.

In any case, for suitable recycling, we suggest disposing of the products separately (differentiated waste) according to the current norms.

**DO NOT DISCARD ANY PACKAGING MATERIALS IN THE ENVIRONMENT!**

## Technical Specifications

Model	CE-CN-0350-G	CE-CN-0610-D
Power	1.8 kW	3.6 kW
Temperature	137.7°C - 298.9°C / 280°F - 570°F	
Cooking Area	14" x 19" / 356 x 483mm	24" x 19" / 610 x 483mm
Electrical	110V / 60Hz / 1	240V / 60Hz / 1
Weight	97.8 lbs. / 43 kgs.	123 lbs. / 56 kgs.
Dimensions	25.25" x 16.5" x 11" 641 x 419 x 279mm	25.25" x 26" x 11" 641 x 660 x 279mm
Item Number	41885	41886

# *Installation*

---

Take out the CHAR BOILER from the packaging and locate the unit on a firm level surface.

When this appliance is to be positioned in close proximity to a wall, partitions, kitchen furniture, decorative finished, etc., it is recommended that they be made of non-combustible material, if not, they shall be clad with a suitable non-combustible heat-insulating material, and that the closet attention be paid to fire prevention regulations.

Once the appliance has been placed in position by consulting International Standards and regulations. Cleaning the cast iron griller/griddle thoroughly is advised. Warm up the cast iron plate for 30 minutes until all smoke and/or odor has dissipated, unplug the unit, after the griller/griddle is cooled, take out the griller/griddle from the unit. Scrub the surface with steel wool and detergent to remove the coating, then use warm, soapy water to clean, dry and put back the griller/griddle on the unit.

**NEVER USE COLD WATER ON THE HOT PLATE.**

The unit is ready to use.

# *Operation*

---

Plug in the unit, the red light will turn on. Turn the thermostat dial to the max setting for about 30 minutes. Cook the desired food product.

When not operating, turn off the thermostat and unplug the unit.

# *Maintenance*

---

The CHAR BOILER should be cleaned using warm, soapy water after each day's operation.

For cleaning grilling plate, please use warm soapy water while still warm. Do not use cold water on warm plate.

Do not immerse completely in water to clean.

The appliance is not to be cleaned with a water jet.

## **HELP**

If the CHAR BOILER does not work, please check the following:

1. The power supply is correct and the thermostat is turned on.
2. The thermostat is correct.

# Maintenance

---

3. The element is clear.

## REFERENCE

Item Number	Model Number	Description	Manufacturer Model Number
41885	CE-CN-0350-G	Char Broiler 14" / 350mm 120V/60Hz/1 including Grill Plate and Griddle Plate QPS	PA50300
41886	CE-CN-0610-D	Char Broiler 24" / 610mm 240V/60Hz/1 Double Control Grill Plate and Griddle Plate QPS	PA50311

# Parts Breakdown

Model CE-CN-0350-G 41885

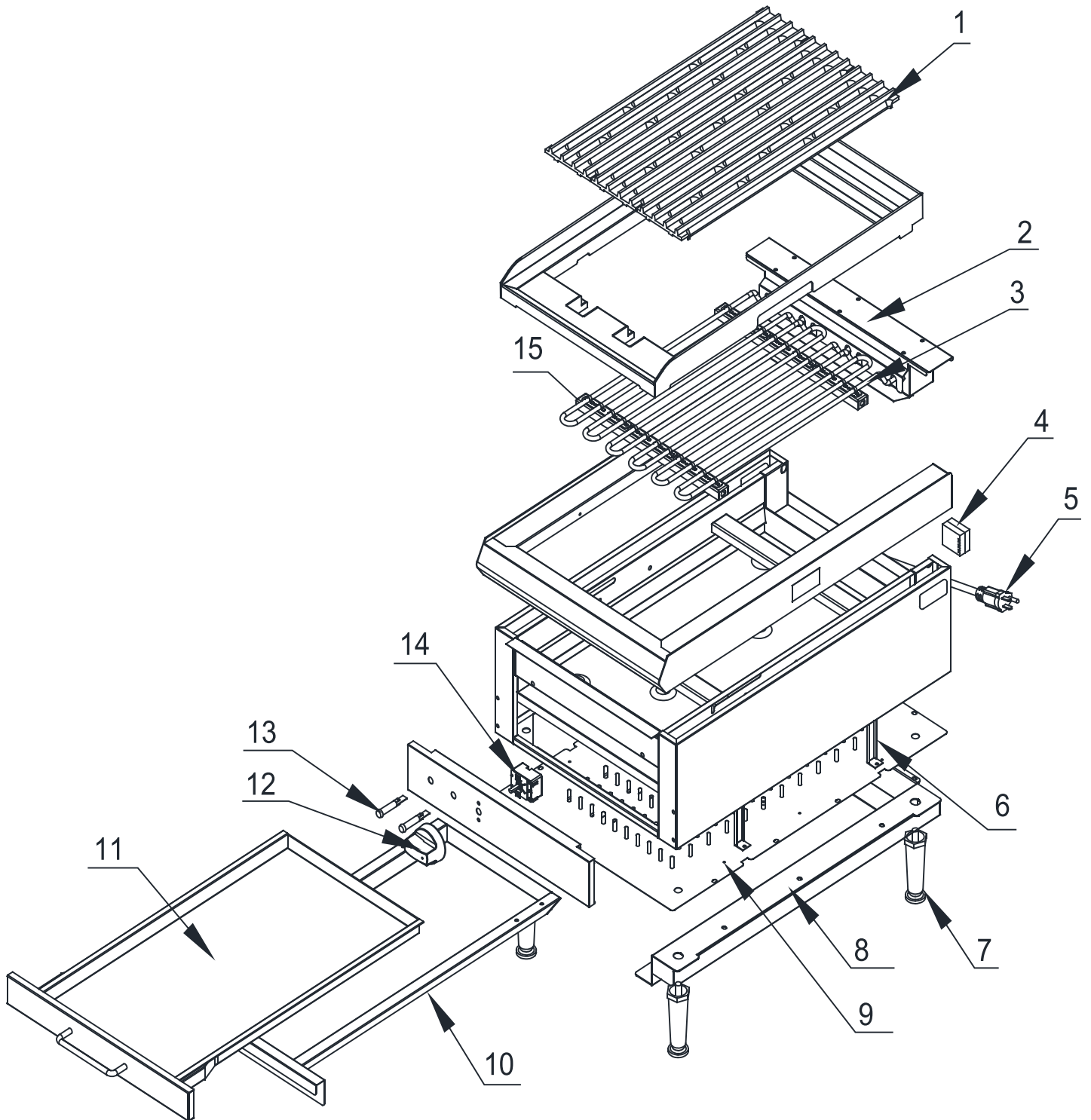

# Parts Breakdown

Model CE-CN-0610-D 41886

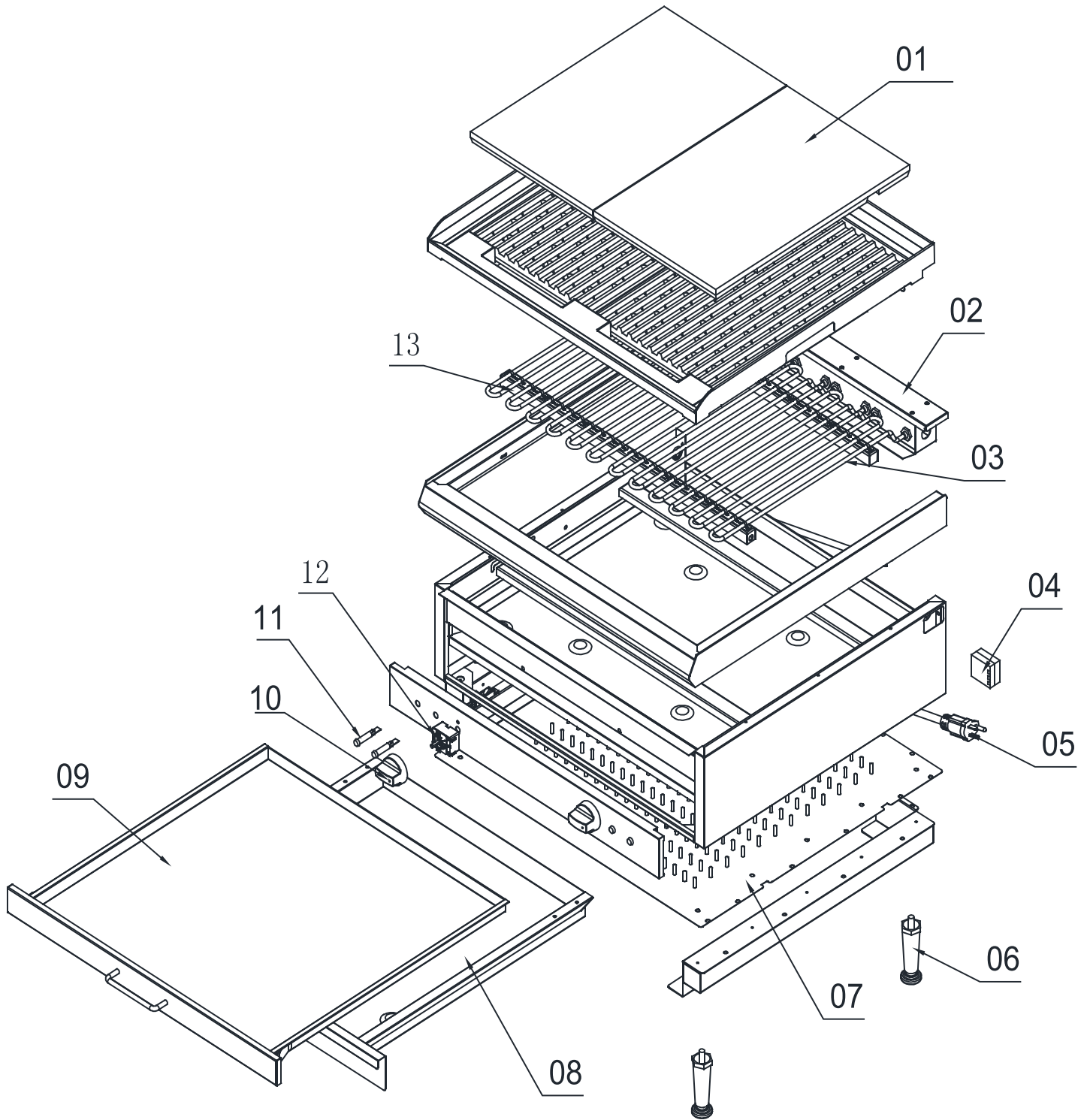

# Parts Breakdown

## Model CE-CN-0350-G 41885

Item No.	Description	Position	Item No.	Description	Position	Item No.	Description	Position
65545	Grill (Ribbed) for PA50300	1	65551	Support Frame for PA50300	6	65557	Knob for PA50300	12
65546	Grill (Flat) for PA50300	1	65552	Feet for PA50300	7	65558	Indicator Light for PA50300	13
65547	Element Box for PA50300	2	65553	Tray Tracks for PA50300	8	65559	Thermostat 1P for PA50300	14
65548	Element for PA50300	3	65554	Bottom Cover for PA50300	9	65560	Element Support for PA50300	15
65549	Thermal Cut Out 3P for PA50300	4	65555	Tray for PA50300	10			
65550	Plug and Lead for PA50300	5	65556	Inside Body for PA50300	11			

## Model CE-CN-0610-D 41886

Item No.	Description	Position	Item No.	Description	Position	Item No.	Description	Position
65561	Grill (Ribbed) for PA50311	1	65569	Plug and Lead for PA50311	5	65557	Knob for PA50311	10
65562	Grill (Flat) for PA50311	1	65552	Feet for PA50311	6	65558	Indicator Light for PA50311	11
65563	Element Box for PA50311	2	65565	Bottom Cover for PA50311	7	65559	Thermostat 1P for PA50311	12
65564	Element for PA50311	3	65566	Tray for PA50311	8	65568	Element Support for PA50311	13
65549	Thermal Cut Out 3P for PA50311	4	65567	Inside Body for PA50311	9			

# Electrical Schematics

Model CE-CN-0350-G 41885

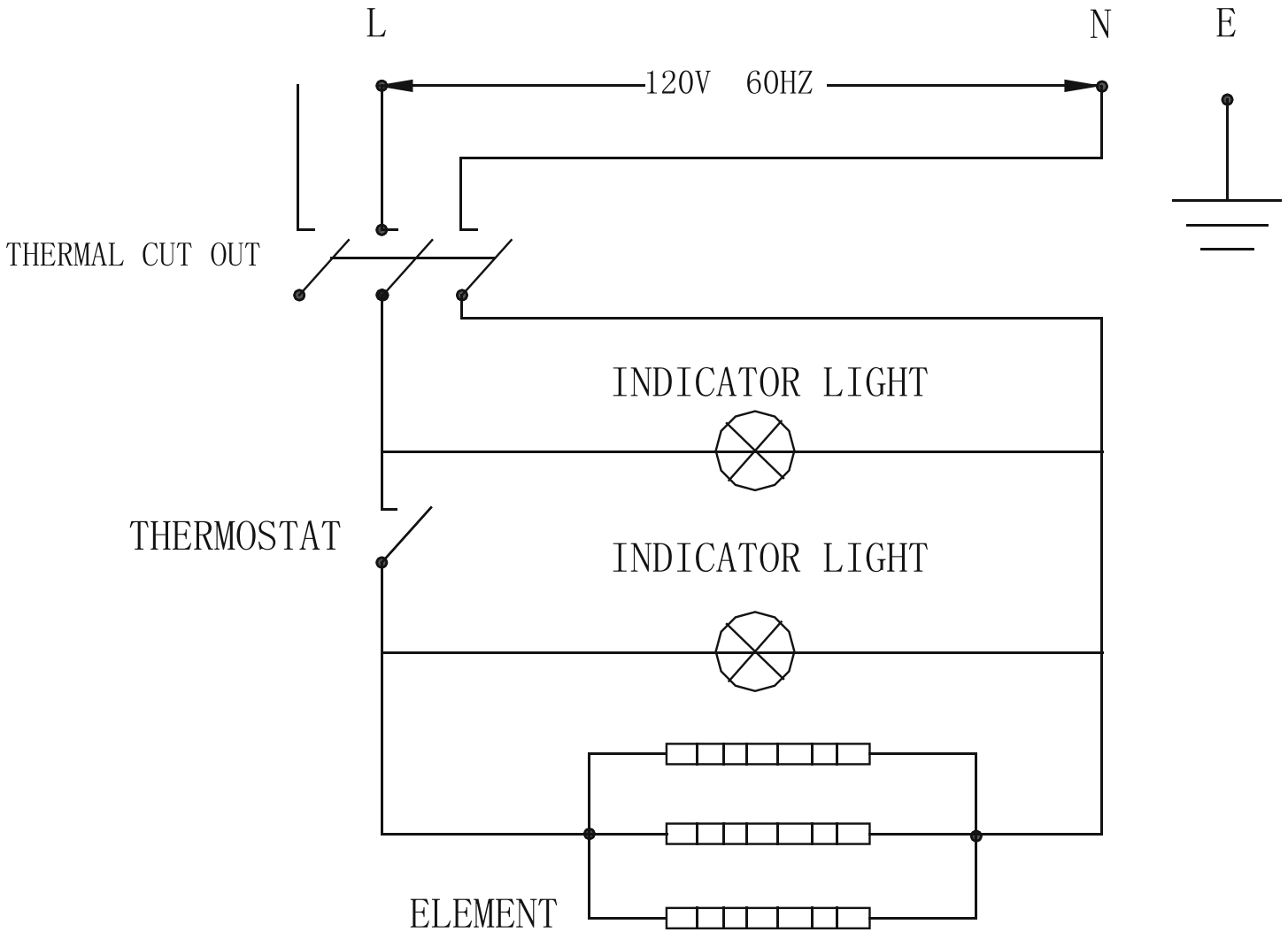

# Electrical Schematics

Model CE-CN-0610-D 41886

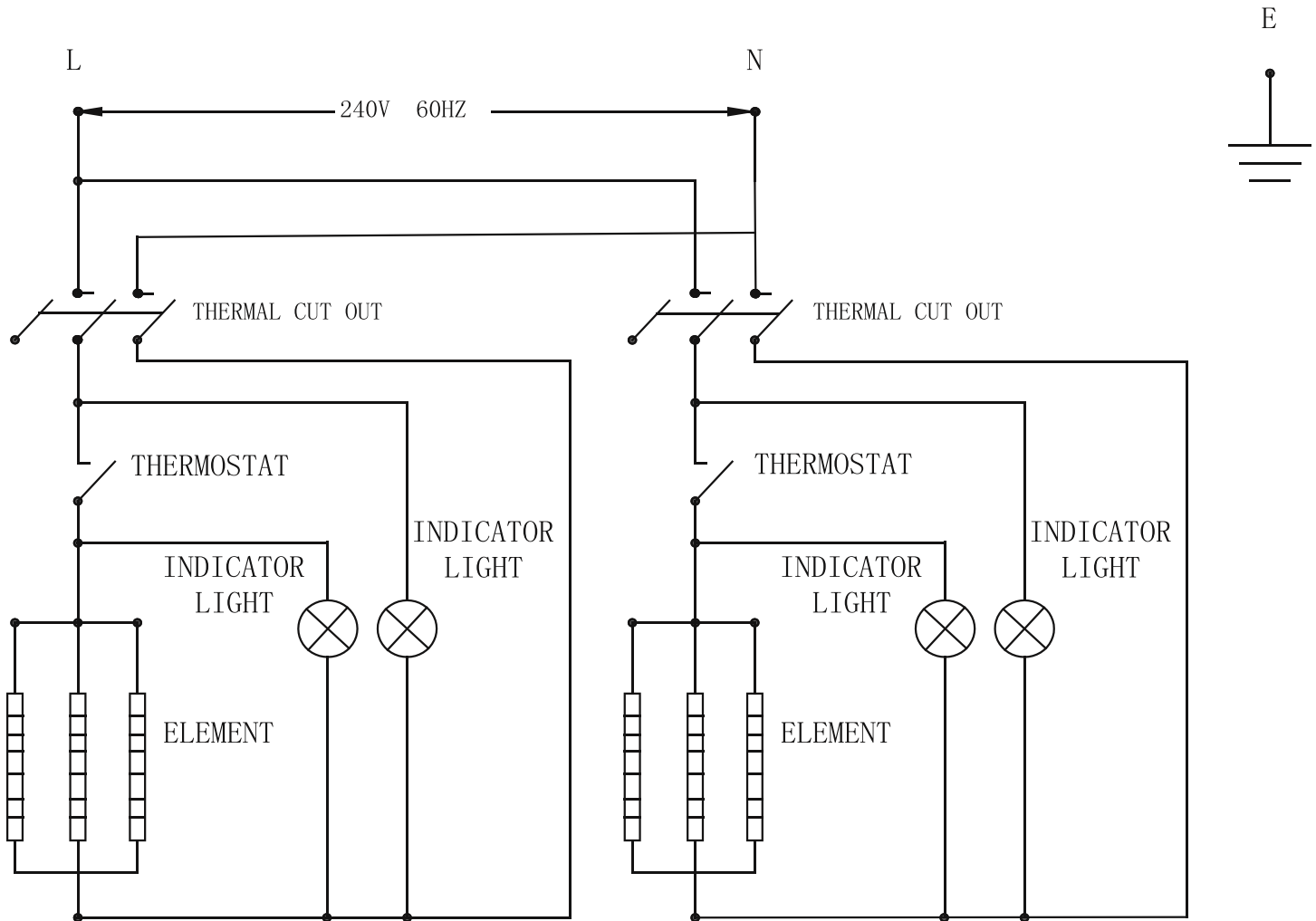







# Warranty Registration

Thank you for purchasing an Omcan product. To register your warranty for this product, complete the information below, tear off the card at the perforation and then send to the address specified below. You can also register online by visiting:

Merci d'avoir acheté un produit Omcan. Pour enregistrer votre garantie pour ce produit, complétez les informations ci-dessous, détachez la carte au niveau de la perforation, puis l'envoyer à l'adresse spécifiée ci-dessous. Vous pouvez également vous inscrire en ligne en visitant:

Gracias por comprar un producto Omcan usted. Para registrar su garantía para este producto, complete la información a continuación, cortar la tarjeta en la perforación y luego enviarlo a la dirección indicada a continuación. También puede registrarse en línea en:

[www.omcan.com/warrantyregistration.html](http://www.omcan.com/warrantyregistration.html)

For mailing in Canada

Pour postale au Canada

Por correo en Canadá

**OMCAN**

PRODUCT WARRANTY REGISTRATION

3115 Pepper Mill Court,

Mississauga, Ontario

Canada, L5L 4X5

For mailing in the US

Pour diffusion aux États-Unis

Por correo en los EE.UU.

**OMCAN**

PRODUCT WARRANTY REGISTRATION

4450 Witmer Industrial Estates, Unit 4,

Niagara Falls, New York

USA, 14305

*or email to: [service@omcan.com](mailto:service@omcan.com)*



Purchaser's Information

Name: \_\_\_\_\_

Address: \_\_\_\_\_

City: \_\_\_\_\_ Province or State: \_\_\_\_\_ Postal or Zip: \_\_\_\_\_

Country: \_\_\_\_\_

Dealer from which Purchased: \_\_\_\_\_

Dealer City: \_\_\_\_\_ Dealer Province or State: \_\_\_\_\_

Invoice: \_\_\_\_\_

Model Name: \_\_\_\_\_ Model Number: \_\_\_\_\_

Machine Description: \_\_\_\_\_

Date of Purchase (MM/DD/YYYY): \_\_\_\_\_

Would you like to extend the warranty?  Yes  No

Company Name: \_\_\_\_\_

Telephone: \_\_\_\_\_

Email Address: \_\_\_\_\_

Type of Company:

Restaurant  Bakery  Deli

Butcher  Supermarket  Caterer

Institution (*specify*): \_\_\_\_\_

Other (*specify*): \_\_\_\_\_

Serial Number: \_\_\_\_\_

Date of Installation (MM/DD/YYYY): \_\_\_\_\_

**Thank you for choosing Omcan | Merci d'avoir choisi Omcan | Gracias por elegir Omcan**



Since 1951 Omcan has grown to become a leading distributor of equipment and supplies to the North American food service industry. Our success over these many years can be attributed to our commitment to strengthen and develop new and existing relationships with our valued customers and manufacturers. Today with partners in North America, Europe, Asia and South America, we continually work to improve and grow the company. We strive to offer customers exceptional value through our qualified local sales and service representatives who provide convenient access to over 3,500 globally sourced products.

---

Depuis 1951 Omcan a grandi pour devenir un des “leaders” de la distribution des équipements et matériel pour l’industrie des services alimentaires en Amérique du Nord. Notre succès au cours de ces nombreuses années peut être attribué à notre engagement à renforcer et à développer de nouvelles et existantes relations avec nos clients et les fabricants de valeur. Aujourd’hui avec des partenaires en Amérique du Nord, Europe, Asie et Amérique du Sud, nous travaillons continuellement à améliorer et développer l’entreprise. Nous nous efforçons d’offrir à nos clients une valeur exceptionnelle grâce à nos ventes locales qualifiées et des représentants de service qui offrent un accès facile à plus de 3500 produits provenant du monde entier.

---

Desde 1951 Omcan ha crecido hasta convertirse en un líder en la distribución de equipos y suministros de alimentos en América del Norte industria de servicios. Nuestro éxito en estos años se puede atribuir a nuestro compromiso de fortalecer y desarrollar nuevas relaciones existentes con nuestros valiosos clientes y fabricantes. Hoy con socios de América del Norte, Europa, Asia y América del Sur, que trabajan continuamente para mejorar y crecer la empresa. Nos esforzamos por ofrecer a nuestros clientes valor excepcional a través de nuestro local de ventas y representantes de los servicios que proporcionan un fácil acceso a más de 3,500 productos con origen a nivel mundial.

