

36" Commercial Gas Range with 6 Burner and Standard Oven – NG/LP

SKU: 12000-217 12000-983



Boost efficiency in your busy kitchen with the Omcan 36" Commercial Range featuring 6 powerful burners and a standard oven.

These gas ranges includes six 30,000 BTU open top burners, delivering the high-performance heat needed for boiling and simmering with precision. The 31,000 BTU standard oven adds versatility, making it easy to warm dishes or bake a variety of desserts. With a broad temperature range of 121°C to 288°, this range is built to handle a wide array of cooking tasks, from everyday meals to complex recipes.



TECHNICAL DRAWING

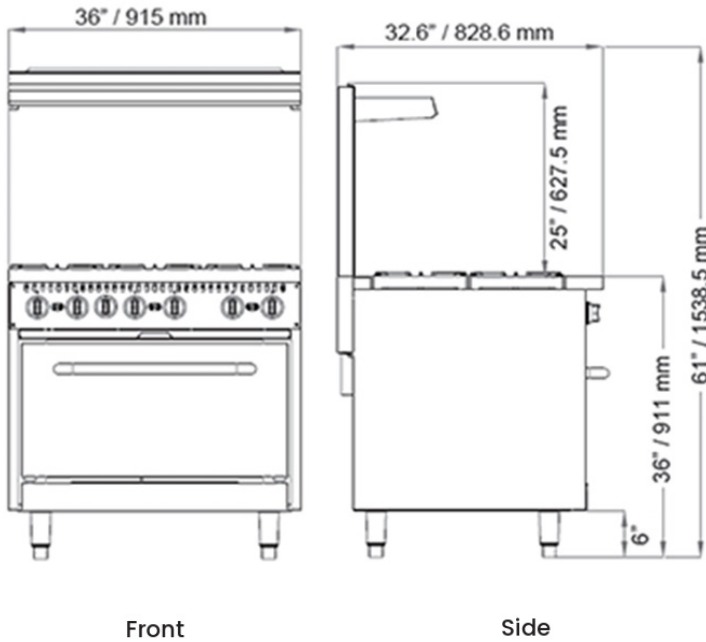

Front

Side

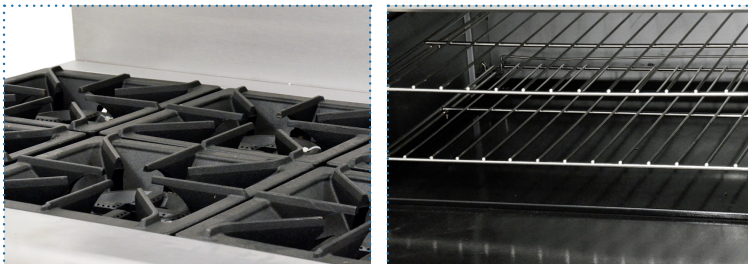

TECHNICAL SPECIFICATION

SKU	12000-217
Gas Type	Natural Gas
Number of Burners	6
BTU	Total: 211,000 BTU Each Burner: 30,000 BTU Oven: 31,000 BTU
Oven Capacity	5.58 cu.ft. 158L
Temperature Range	121°C - 288°C 250°F - 550°F
Net Dimensions	36" x 32.6" x 61" 915 x 828.6 x 1538.5 mm
Net Weight	368 lb. 167 kg.
Gross Dimensions	41" x 40" x 44" 1040 x 1010 x 1120 mm
Gross Weight	456 lb. 207 kg.

FEATURES:

- Spacious 5.58 cu.ft. oven capacity
- Durable stainless steel construction on front, sides, and back
- Heavy-duty, adjustable 6" stainless steel legs for stability
- Six powerful 30,000 BTU burners for high-performance cooking
- Includes six heavy-duty flat cast-iron cooking grates
- Long-lasting stainless steel pilot for enhanced durability
- Easy-to-clean pull-out crumb tray with rounded edges to minimize heat transfer
- Designed for compatibility with 3/4"NPT gas connection

**gas hose sold separately*



TECHNICAL DRAWING

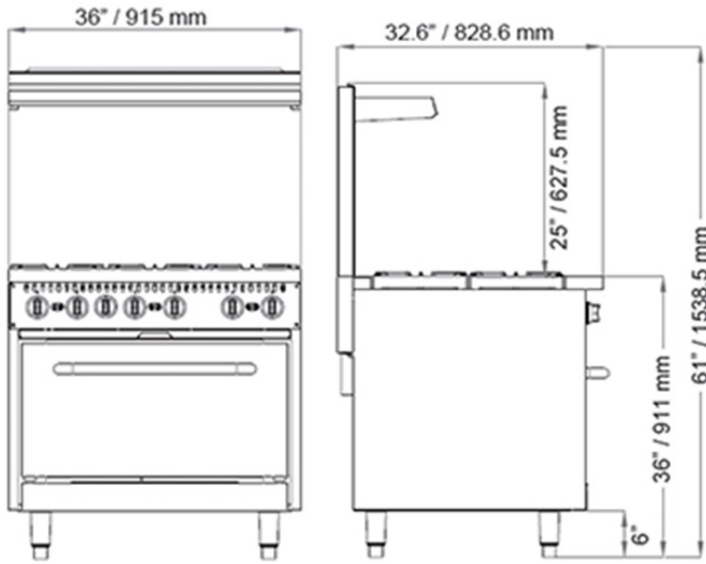

Front

Side

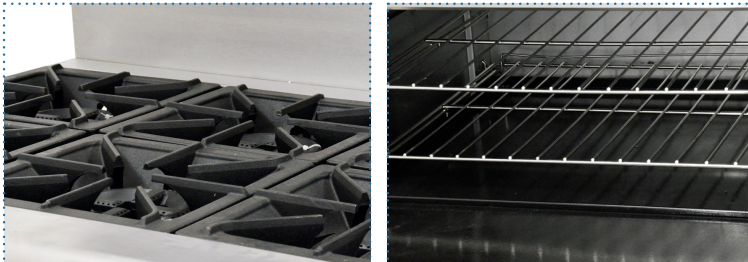

TECHNICAL SPECIFICATION

SKU	12000-983
Gas Type	Liquid Propane
Number of Burners	6
BTU	Total: 211,000 BTU Each Burner: 30,000 BTU Oven: 31,000 BTU
Oven Capacity	5.58 cu.ft. 158L
Temperature Range	121°C - 288°C 250°F - 550°F
Net Dimensions	36" x 32.6" x 61" 915 x 828.6 x 1538.5 mm
Net Weight	368 lb. 167 kg.
Gross Dimensions	41" x 40" x 44" 1040 x 1010 x 1120 mm
Gross Weight	456 lb. 207 kg.

FEATURES:

- Spacious 5.58 cu.ft. oven capacity
- Durable stainless steel construction on front, sides, and back
- Heavy-duty, adjustable 6" stainless steel legs for stability
- Six powerful 30,000 BTU burners for high-performance cooking
- Includes six heavy-duty flat cast-iron cooking grates
- Long-lasting stainless steel pilot for enhanced durability
- Easy-to-clean pull-out crumb tray with rounded edges to minimize heat transfer
- Designed for compatibility with 3/4"NPT gas connection

**gas hose sold separately*

